

SIEMENS



Industrial Identification Systems











SIMATIC Ident

Catalog
ID 10

Edition
2016

siemens.com/ident

Related catalogs

<p>Industrial Communication SIMATIC NET</p> <p>E86060-K6710-A101-B8-7600</p>	<p>IK PI</p> 	<p>Weighing Technology Products for Weighing Technology</p> <p>E86060-K6410-A101-A4-7600</p>	<p>WT 10</p> 
<p>SIMATIC Products for Totally Integrated Automation</p> <p>E86060-K4670-A101-B5-7600</p>	<p>ST 70</p> 	<p>SIMATIC HMI / PC-based Automation Human Machine Interface Systems PC-based Automation</p> <p>E86060-K4680-A101-C2-7600</p>	<p>ST 80/ST PC</p> 
<p>SITOP Power supply SITOP</p> <p>E86060-K2410-A101-B1-7600</p>	<p>KT 10.1</p> 	<p>SITRAIN Training for Industry</p> <p>Only available in German E86060-K6850-A101-C5</p>	<p>ITC</p> 
<p>Industrial Controls SIRIUS</p> <p>PDF (E86060-K1010-A101-A6-7600)</p>	<p>IC 10</p> 	<p>Products for Automation and Drives Interactive Catalog, DVD</p> <p>E86060-D4001-A510-D6-7600</p>	<p>CA 01</p> 
<p>Safety Integrated Safety Technology for Factory Automation</p> <p>E86060-K7010-A101-A3-7600</p>	<p>SI 10</p> 	<p>Industry Mall Information and Ordering Platform in the Internet:</p> <p>www.siemens.com/industrymall</p>	
<p>Process Automation Field Instruments for Process Automation</p> <p>PDF (E86060-K6201-A101-B9-7600)</p>	<p>FI 01</p> 		

Industrial Identification Systems

SIMATIC Ident



Catalog ID 10 · 2016

Supersedes:
Catalog ID 10 · 2014

Refer to the Industry Mall for current updates of
this catalog:

www.siemens.com/industrymall

The products contained in this catalog can also be found
in the Interactive Catalog CA 01.

Article No.: E86060-D4001-A510-D6-7600

Please contact your local Siemens branch.

© Siemens AG 2016

SIMATIC Ident

SIMATIC Ident - for more economic production
and logistics processes
Simple integration into the automation level
Digital Enterprise
RFID systems field data table

1

RFID systems for the HF range

Transponders
SIMATIC RF200
SIMATIC RF300
MOBY D
Antennas

2

RFID system for the UHF range

SIMATIC RF600
Transponders
Readers
Antennas

3

Optical identification

Stationary code reading systems
Handheld reading systems
Verification systems
Optical character recognition (OCR)
Object recognition

4

Communication modules for RFID systems and optical identification

RFID standard cables

SCALANCE network components

5

Appendix

6



The products and systems described in
this catalog are manufactured/distributed
under application of a certified quality
management system in accordance with
DIN EN ISO 9001. The certificate is recog-
nized by all IQNet countries.

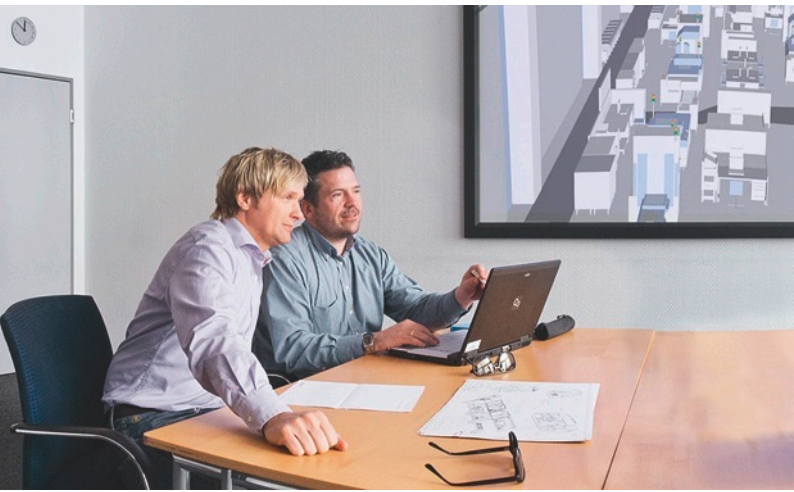



Answers for industry.

Integrated technologies, vertical market expertise and services for greater productivity, energy efficiency, and flexibility.

Siemens is the world's leading supplier of innovative and environmentally friendly products and solutions for industrial companies. End-to-end automation technology and industrial software, solid market expertise, and technology-based services are the levers we use to increase our customers' productivity, efficiency and flexibility.

We consistently rely on integrated technologies and, thanks to our bundled portfolio, we can respond more quickly and flexibly to our customers' wishes. With our globally unmatched range of automation technology, industrial control and drive technology as well as industrial software, we equip companies with exactly what they need over their entire value chain – from product design and development to production, sales and service. Our industrial customers benefit from our comprehensive portfolio, which is tailored to their market and their needs.

Market launch times can be reduced by up to 50% due to the combination of powerful automation technology and industrial software. At the same time, the costs for energy or waste water for a manufacturing company can be reduced significantly. In this way, we increase our customers' competitive strength and make an important contribution to environmental protection with our energy-efficient products and solutions.

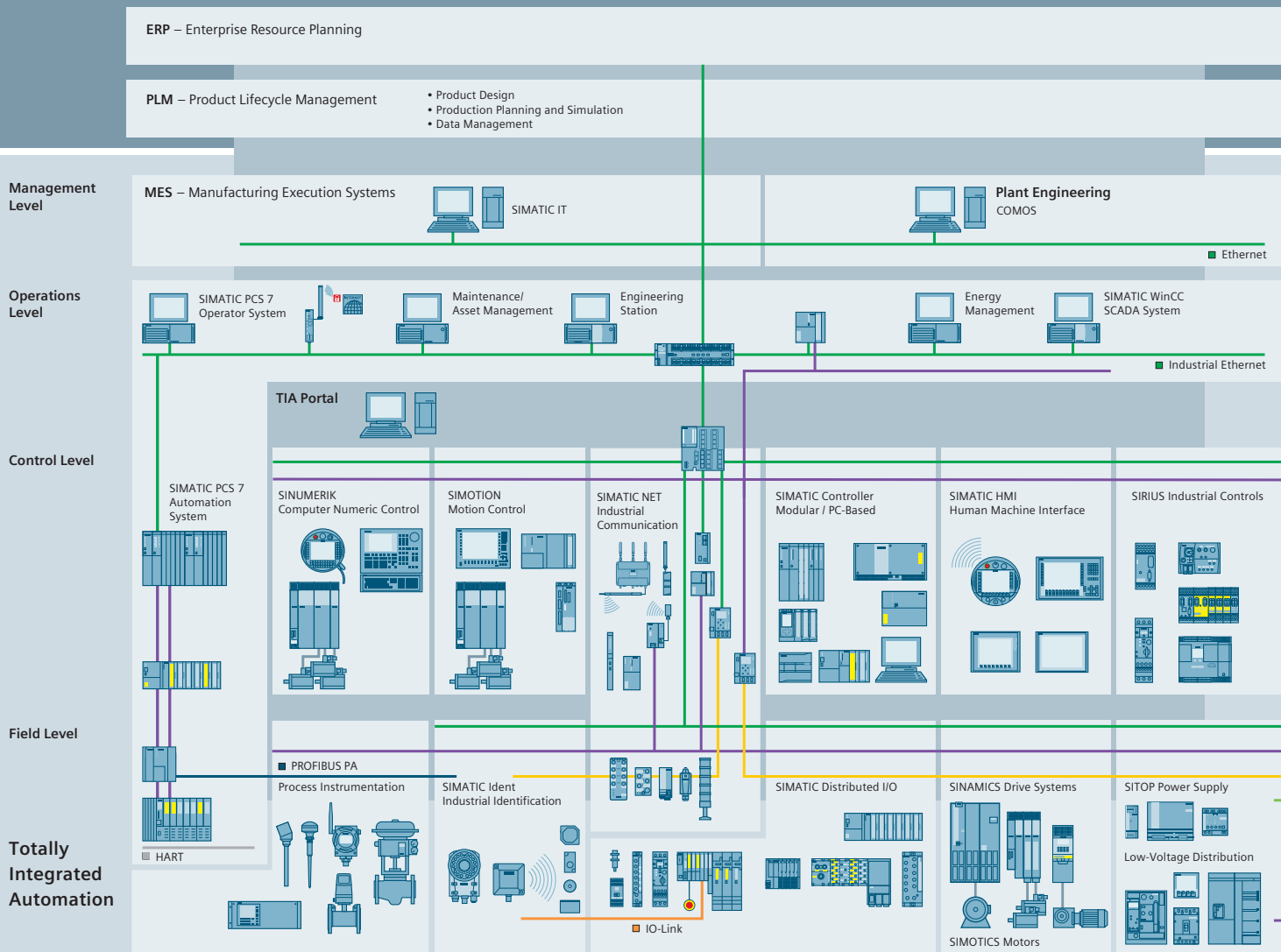

Efficient automation starts with efficient engineering.

Totally Integrated Automation: Efficiency driving productivity.

Efficient engineering is the first step toward better production that is faster, more flexible, and more intelligent. With all components interacting efficiently, Totally Integrated Automation (TIA) delivers enormous time savings right from the engineering phase. The result is lower costs, faster time-to-market, and greater flexibility.

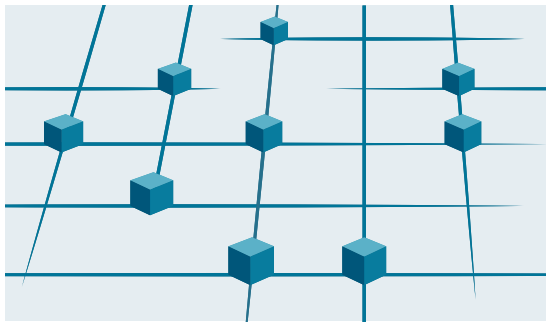

Totally Integrated Automation
Efficient interoperability of all automation components



- PROFINET
- Industrial Ethernet
- PROFIBUS
- AS-Interface
- KNX GAMMA instabus

Totally
Integrated
Power



A unique complete approach for all industries

As one of the world's leading automation suppliers, Siemens provides an integrated, comprehensive portfolio for all requirements in process and manufacturing industries. All components are mutually compatible and system-tested. This ensures that they reliably perform their tasks in industrial use and interact efficiently, and that each automation solution can be implemented with little time and effort based on standard products. The integration of many separate individual engineering tasks into a single engineering environment, for example, provides enormous time and cost savings.

With its comprehensive technology and industry-specific expertise, Siemens is continuously driving progress in manufacturing industries – and Totally Integrated Automation plays a key role.

Totally Integrated Automation creates real value added in all automation tasks, especially for:

- **Integrated engineering**
Consistent, comprehensive engineering throughout the entire product development and production process
- **Industrial data management**
Access to all important data occurring in productive operation – along the entire value chain and across all levels
- **Industrial communication**
Integrated communication based on international cross-vendor standards that are mutually compatible
- **Industrial security**
Systematic minimization of the risk of an internal or external attack on plants and networks
- **Safety Integrated**
Reliable protection of personnel, machinery, and the environment thanks to seamless integration of safety technologies into the standard automation

Making things right with Totally Integrated Automation

Totally Integrated Automation, industrial automation from Siemens, stands for the efficient interoperability of all automation components. The open system architecture covers the entire production process and is based on end-to-end shared characteristics: consistent data management, global standards, and uniform hardware and software interfaces.

Totally Integrated Automation lays the foundation for comprehensive optimization of the production process:

- Time and cost savings due to efficient engineering
- Minimized downtime due to integrated diagnostic functions
- Simplified implementation of automation solutions due to global standards
- Better performance due to interoperability of system-tested components

SIMATIC Ident

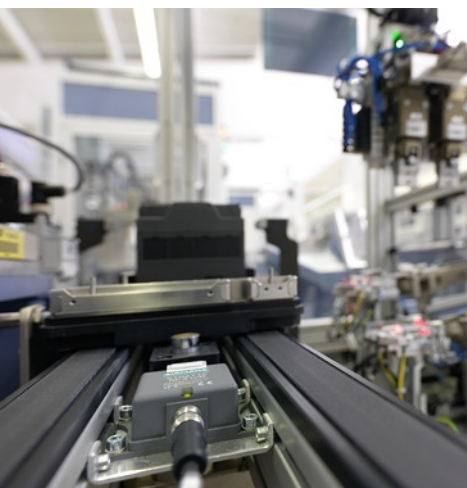

1/2	SIMATIC Ident - for more economic production and logistics processes
1/4	Production Control
1/4	Asset Management
1/5	Tracking and Tracing
1/5	Supply Chain Management
1/6	Simple integration into the automation level
1/7	Digital Enterprise
1/9	RFID systems field data table

SIMATIC Ident

SIMATIC Ident - for more economic production and logistics processes

1

To be able to stay ahead in dynamic markets in the face of increasing competition, stricter standards and statutory obligations, shorter product life cycles, more individual customer requirements, and increasingly globalized value-added, companies must be in a position to significantly boost the efficiency of their value added chains. In production control, asset management, tracking & tracing as well as in supply chain management. By using innovative identification technologies, companies can gain an important advantage. In connection with high-performance, reliable communication networks, this creates the infrastructure that prepares companies for the forthcoming industrial digitization.

We offer SIMATIC Ident, a unique portfolio for industrial identification which can provide the perfect solution for your requirements while keeping you flexible for the future.

The right identification technology depends on factors such as sensing distance, lighting conditions, single or repeat markings, as well as environmental effects such as temperature and pollution.

Whether RFID, barcode, DMC or OCR:

every technology has its specific strengths.

Optical character recognition is used for cases in which codes must also be readable for persons, such as use-by dates.

2D codes and RFID impress customers with their high level of data security and have proved reliable even under harsh industrial conditions.

The decisive criterion for an identification system:

Your individual application.

Identification, mobile data storage: RFID



RFID is the ideal solution when there is no line of sight between the reader and the marking, large volumes of data or wide ranges are required, or the stored information has to be changed. Here the product or object is fitted with a memory chip that can be programmed and read using radio techniques. With low-cost SmartLabels available for logistics, rugged data memories for assembly lines as well as transponders with a wide range, RFID is perfectly suited to a variety of different applications.

Our intelligent SIMATIC RF system family offers you transparency without gaps. Data is therefore available at any time along the complete production and distribution chain - for perfect control and optimization of material flow and logistics.

Identification, verification: Optical identification



When higher performance is required, 2D codes are recommended as an alternative to barcodes. 2D codes offer more memory capacity, higher reading rates, and enhanced reading security. They can be applied inexpensively, e.g. together with shipping labels. They also enable products to be marked directly (Direct Part Marking, DPM) using lasers, printing or dot-peening, which is extremely resistant to external influences. 2D codes can be read with complete reliability even from a small viewing angle or under difficult lighting conditions.

With our optical reading devices, we offer you the ideal solution for reading and verifying 1D and 2D codes as well as for text recognition (OCR) and object recognition (Pat-Genius) for the reliable tracing of production batches beyond the manufacturing plant.

SIMATIC Ident

SIMATIC Ident - for more economic production and logistics processes

1

Production Control

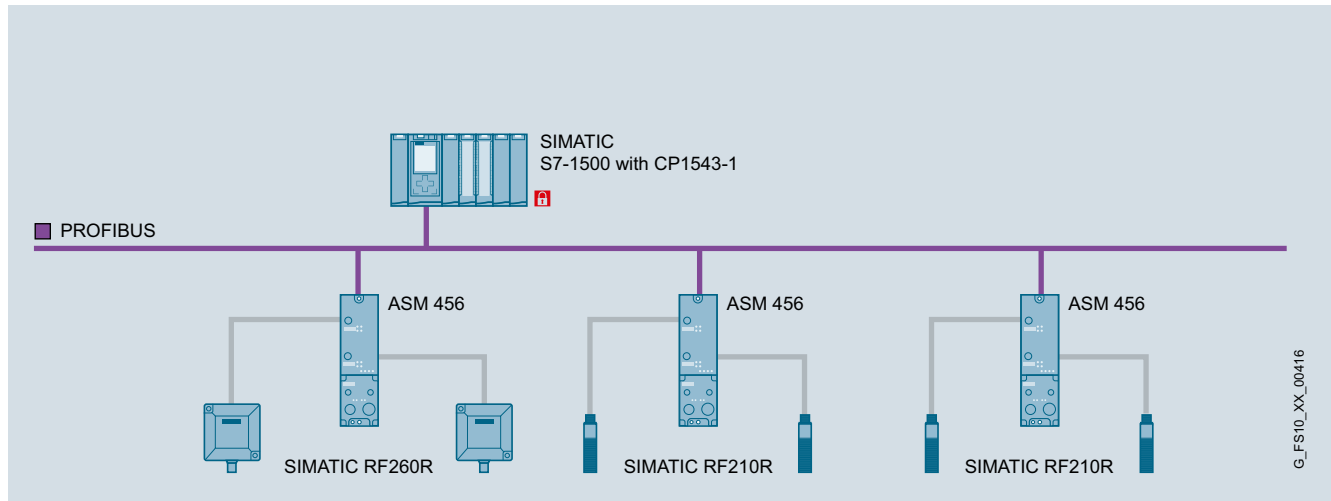

Example configuration of a small assembly line with SIMATIC RF200

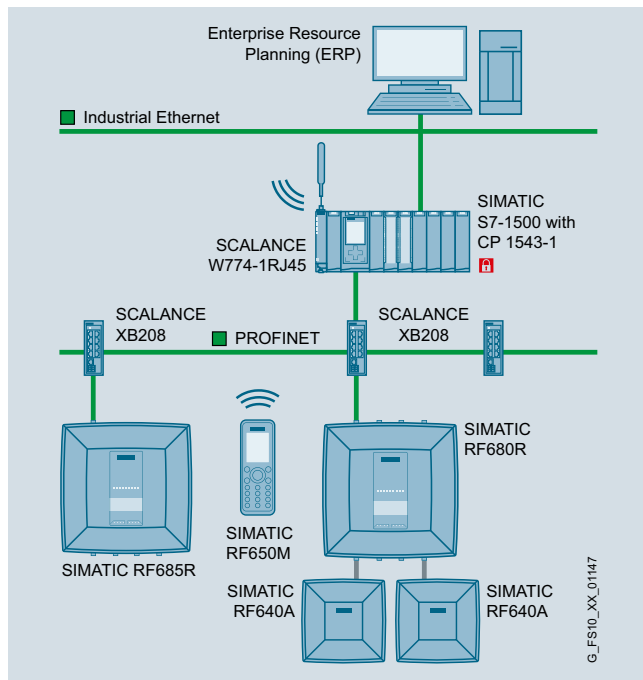

All over the world, consumers want more and more individual products. Versatile production and material flow control with industrial identification handles the requirements for growing product variety throughout the manufacturing process. This is made possible by reliable, efficient and cost-effective make-to-order production.

Example configuration of a small assembly line with SIMATIC RF600, SCALANCE W and SCALANCE X

Asset Management

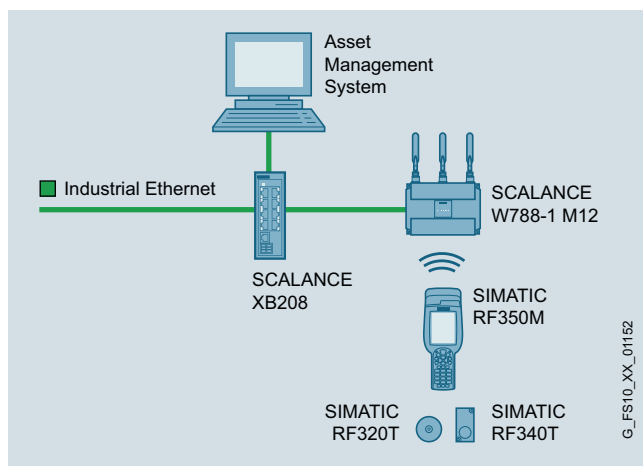

Assets such as tools, plant parts, or containers are essential for production and logistics. Industrial identification ensures they are used efficiently. The inventory can be acquired in real time and the status determined precisely. This means that the use of the assets can be monitored perfectly at any time and optimized specifically for stock quantity, capacity and maintenance.

Example configuration of asset management with the SIMATIC RF350M handheld terminal

Tracking & Tracing

With industrial identification, each product leaves a digital trail that can be seamlessly traced and documented back to the origin of its individual components. This permits full transparency of the entire product life cycle and therefore the best possible quality.

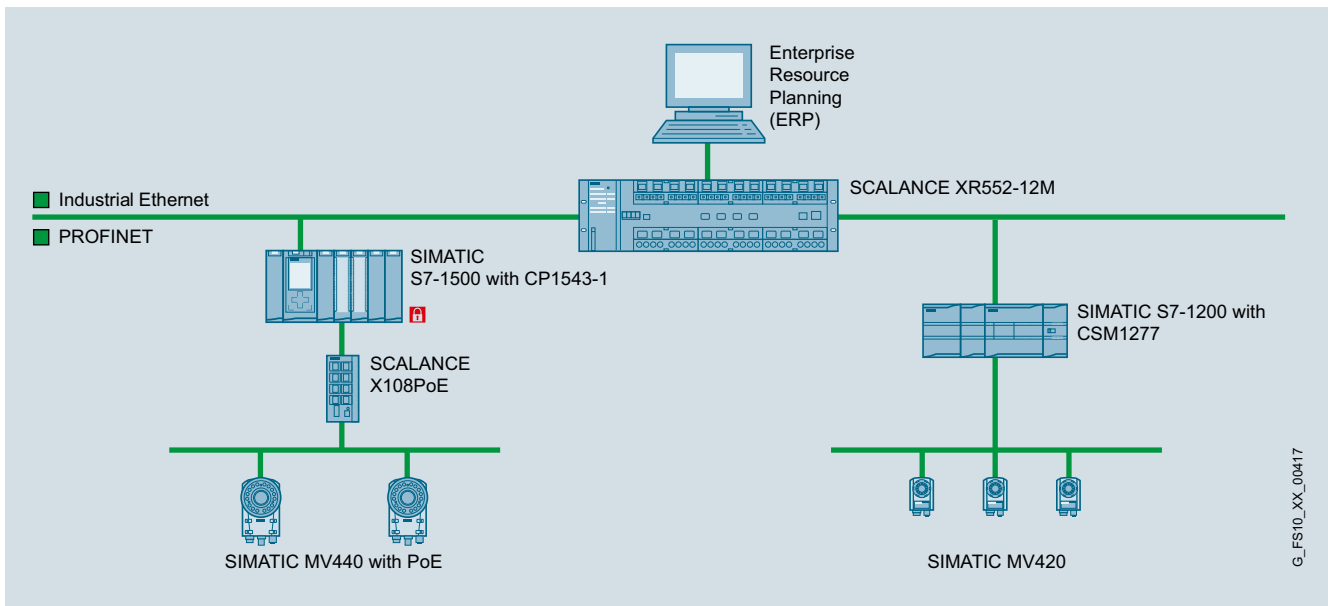

Example configuration of tracking & tracing with optical reading devices

Supply Chain Management

Competitive production on an industrial scale requires global supply chains for individual parts and components. Industrial identification makes these supply chains transparent and predictable, and facilitate optimum planning. This avoids delivery bottlenecks and downtimes, optimizes warehouse stocks and improves profit margins.

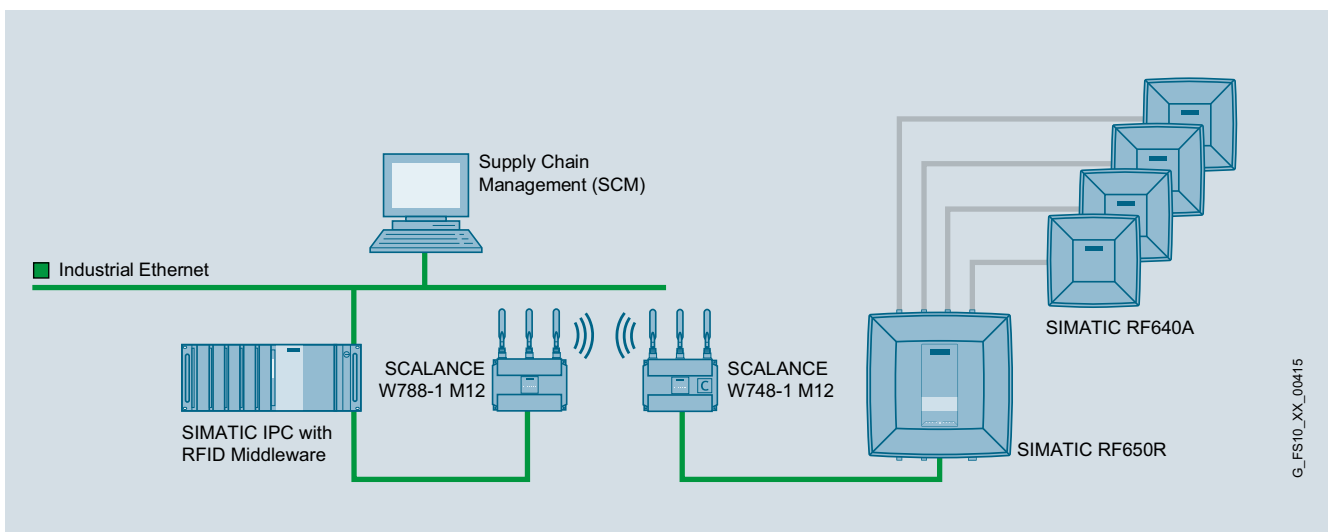

Example configuration of a logistics portal with SIMATIC RF600 and SCALANCE W

SIMATIC Ident

Simple integration into the automation level

1

With our SIMATIC Ident portfolio we can offer you the right solution: Using communication modules and convenient function blocks, it is easy to connect SIMATIC Ident systems to the PLC (such as SIMATIC) or the IT landscape. This ensures that you have a system-wide, uniform software architecture and saves considerable outlay and costs in engineering, commissioning and maintenance.

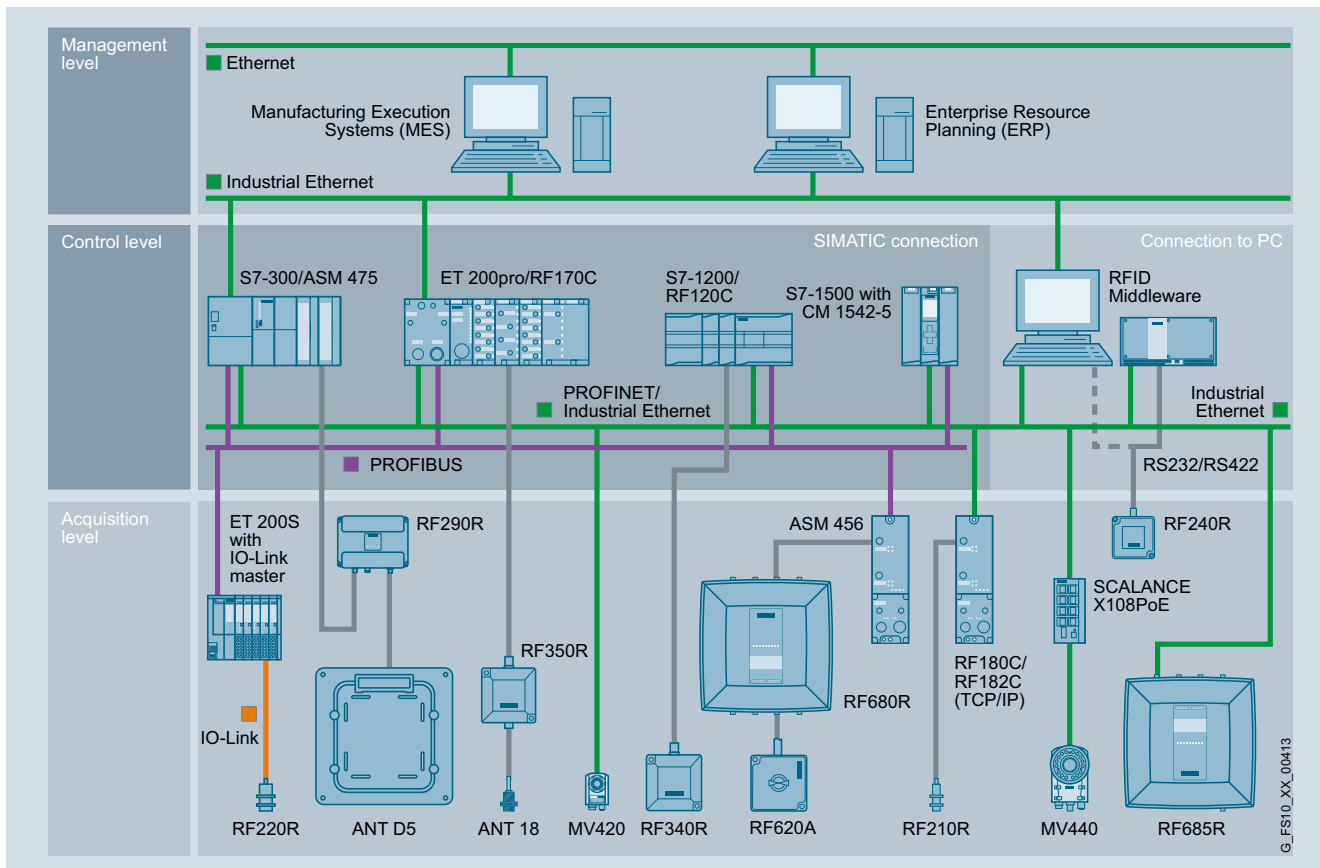

Integration in Totally Integrated Automation

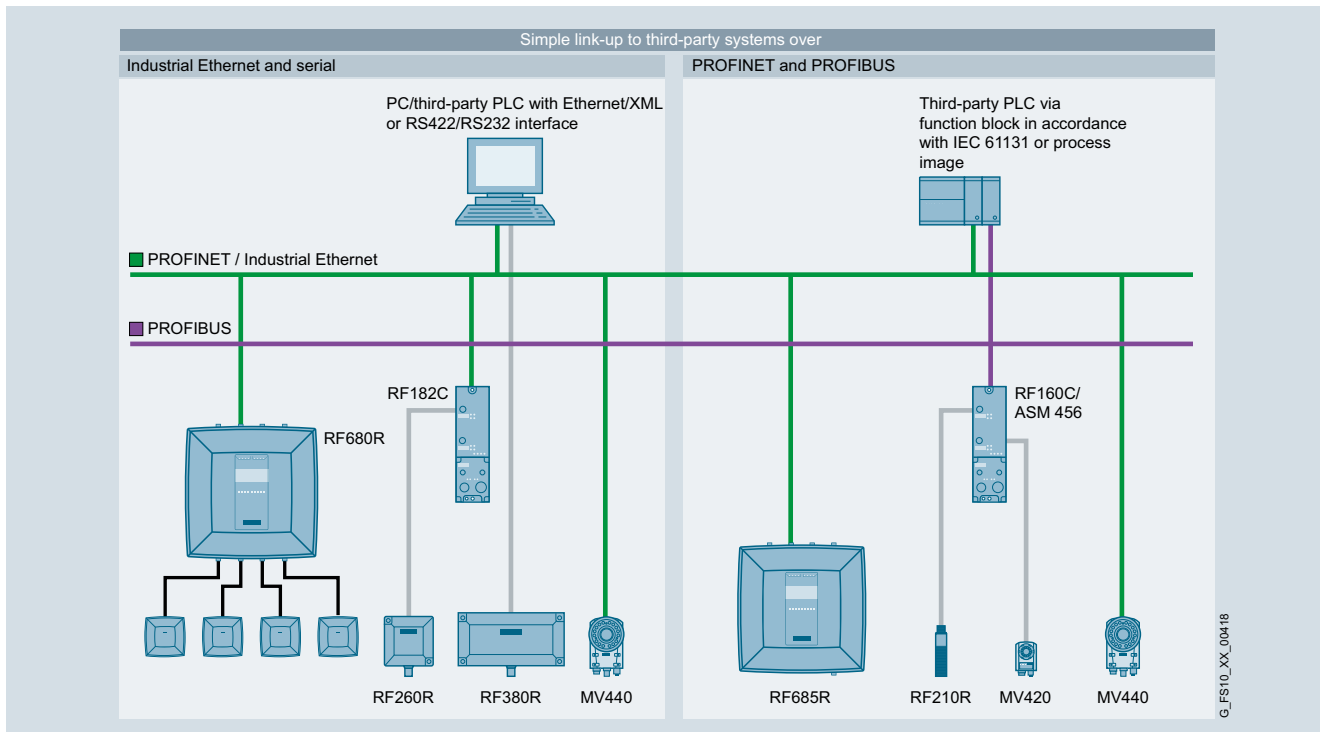

Connection to third-party systems

Digital Enterprise

The Internet serves as an enormous accelerator of business processes and has revolutionized business operations around the world. Not only does it enable enterprises to work more closely and effectively with their business partners, it also puts them in a position to communicate directly with end customers and respond very quickly to specific requests (mass customization). The resulting requirements present the industry and the products and services it provides with new challenges never seen before.

Manufacturing companies are being forced to drastically shorten throughput times with massively improved flexibility in order to keep up with the increasingly strong trend toward individualized mass production. At the same time, they must consistently reduce their consumption of energy and raw materials. Solutions to address these challenges are being developed in initiatives such as the "Internet of Things" or "Industrie 4.0".

































The requirements listed above which arise from the tremendous pace at which the internet economy is developing can no longer be met just by focusing on automation processes in the manufacturing industry. What is required is a holistic approach stretching over the entire value-add chain, starting with the product definition and extending to service and maintenance of the product in everyday use. Special attention must be paid here to a deep level of integration and seamless connection of data with the supplier network.







Essential components for the digital infrastructure are powerful communication networks and reliable, automatic synchronization of digital processes with workflows in the real world. Siemens offers a unique portfolio to deal with both of these aspects: SIMATIC NET for high-performance networks, and SIMATIC Ident for industrial identification with RFID or optical identification. In addition to integrating manufacturers and suppliers in a comprehensive production network, demands with regard to asset management, supply chain management or Tracking & Tracing can also be effectively solved at low cost.

Explanation of symbols appearing below product images

"Highlight" symbols can be found under most product pictures. These symbols refer to the outstanding properties of the particular product. The following table describes the meaning of the symbols.

Symbol	Meaning	Symbol	Meaning
	Device capable of operating in wide temperature range (with specification of range).		The communication module has a PROFINET connection.
	Wide operating distance between transponder and reader possible (with specification of max. distance).		The reader has PROFINET and Ethernet TCP/IP for connecting SIMATIC, SIMOTION, SINUMERIK, PC-based systems and third-party controllers.
	The transponder can be mounted directly onto metal surfaces.		The communication module has an Ethernet connection.
	The transponder or reader is compatible with the ISO protocol.		The communication module has an Ethernet/IP connection.
	The transponder is compatible with the RF300 protocol.		The communication module connects SIMATIC Ident systems to the ET 200pro distributed I/O system.
	The transponder or reader has ATEX approval (with specification of approval).		The communication module connects SIMATIC Ident systems to SIMATIC ET200 M and SIMATIC S7-300
	The transponder or antenna is small in design.		The communication module connects SIMATIC Ident systems to SIMATIC S7-1200.
	The antenna is large in design. This enable a large transmission window.		Web Based Management (WBM): The code reader has an onboard web server and can be configured using a multitude of devices that have browser functionality.
	The reader has a high data transfer rate for wireless transmission.		The functionality of the optical reader is, to a large extent, able to be scaled to different sizes and performance classes with the same user interface and an almost identical electrical interface.
	The transponder or reader has a high processing speed.		The optical reader functions can be dynamically configured using the user interface.
	The transponder has a large user memory (with specification of storage capacity).		The antenna has linear polarization.
	The reader has an RS232 interface for connection to SIMATIC, PC-based systems or third-party controllers.		The antenna has circular polarization.
	The reader can be connected to SIMATIC S7, PROFIBUS, PROFINET, Ethernet/IP or Ethernet TCP/IP via communication modules.		Reader available in Scanmode variant (read-only). In these variants, the reader reads each detected transponder automatically and outputs this data via the serial interface.
	The reader has an IO-Link interface for connection to IO-Link master modules from Siemens or third-party manufacturers.		The optical handheld reader has a USB interface.
	The communication module has a PROFIBUS connection.		The optical handheld reader is suitable for wireless communication.
			The optical handheld reader is equipped with integrated bright field/dark field lighting.
			The device has an RS422 and RS232 interface for connecting readers, optical handheld devices and other serial devices.

Technical specifications

Frequency range	HF			UHF
RFID system	SIMATIC RF200	SIMATIC RF300	MOBY D	SIMATIC RF600
				
Transmission frequency	13.56 MHz	13.56 MHz	13.56 MHz	865 ... 868 MHz (ETSI) 902 ... 928 MHz (FCC) 920 ... 925 MHz (CMIIT)
Range, max.	650 mm	210 mm	380 mm	8 m
Protocol (air interface)	<ul style="list-style-type: none"> • ISO 15693 • ISO 18000-3 	<ul style="list-style-type: none"> • ISO 15693 • ISO 18000-3 • RF300 (proprietary) 	<ul style="list-style-type: none"> • ISO 15693 • ISO 18000-3 	<ul style="list-style-type: none"> • EPCglobal Class 1 Gen 2, • ISO 18000-6B • ISO 18000-6C
Standards, specifications, approvals ¹⁾	<ul style="list-style-type: none"> • EN 300330, 301489, CE • FCC Part 15 • UL/CSA 	<ul style="list-style-type: none"> • EN 300330, 301489, CE • FCC Part 15 • UL/CSA • ATEX 	<ul style="list-style-type: none"> • EN 300330, 301489, CE • FCC Part 15 • UL/CSA 	<ul style="list-style-type: none"> • ETSI EN 302208, CE • FCC • UL
Memory capacity, max.	992 bytes (EEPROM)/ 8 192 bytes (FRAM)	64 KB	992 bytes (EEPROM)/ 2 000 bytes (FRAM)	496 bit EPC 3 424 byte
Maximum data transfer rate for wireless transmission	26.5 Kbps	106 Kbps	26.5 Kbps	300 Kbps
Multitag/Bulk capability	With RF290R reader only	No	Yes	Yes
Special features	<ul style="list-style-type: none"> • Particularly compact designs • For particularly low-cost RFID solutions • IO-Link for simple identification tasks 	<ul style="list-style-type: none"> • High data transfer rate • Extended diagnostic possibilities • High memory capacity 	<ul style="list-style-type: none"> • SIMATIC or PC/IT integration • External antennas for industrial applications 	<ul style="list-style-type: none"> • SIMATIC or PC/IT integration • Data preprocessing in the readers • Special antennas for industrial applications

The following field data table provides a brief summary of all permissible combinations of readers and transponders as well as the most important technical features of the transponders.

This field data table helps by providing an overview of the many different possible combinations of our RFID products.

¹⁾ All current approvals can be found on the Internet at: <http://www.siemens.com/rfid-approvals>

SIMATIC Ident

RFID systems field data table

1

Overview

HF range (RF200, RF300, MOBY D)

Operating distance (mm) between transponder and reader	Transponder Article No.	MDS D165 6GT2600-1AB00-0AX0	MDS D261 6GT2600-1AA01-0AX0	MDS D100 6GT2600-0AD10	MDS D200 6GT2600-1AD00-0AX0	MDS D400 6GT2600-4AD00	MDS D421 6GT2600-4AE00	MDS D521 6GT2600-5AE00	MDS D422 6GT2600-4AF00	MDS D522 6GT2600-5AF00	MDS D522 6GT2600-5AF00-0AX0	MDS D423 6GT2600-4AA00	MDS D124 6GT2600-0AC10	MDS D324 6GT2600-3AC00	MDS D424 6GT2600-4AC00	MDS D524 6GT2600-5AC00	MDS D425 6GT2600-4AG00	MDS D525 6GT2600-5AG00	MDS D126 6GT2600-0AE00	
User memory		112 byte	256 byte	112 byte	256 byte	2 kbyte	2 kbyte	8 kbyte	2 kbyte	8 kbyte	8 kbyte	2 kbyte	112 byte	992 byte	2 kbyte	8 kbyte	2 kbyte	8 kbyte	112 byte	
Temperature range		-25 °C ... 85 °C	-25 °C ... 85 °C	-25 °C ... 80 °C	-20 °C ... 60 °C	-20 °C ... 60 °C	-40 °C ... 100 °C	-40 °C ... 100 °C	-40 °C ... 100 °C	-40 °C ... 100 °C	-40 °C ... 100 °C	-40 °C ... 100 °C	-40 °C ... 180 °C	-40 °C ... 140 °C	-40 °C ... 100 °C	-40 °C ... 100 °C	-40 °C ... 125 °C	-40 °C ... 125 °C	-40 °C ... 100 °C	
L x W x H or Ø x H (mm)		86 x 54 x 0.3	55 x 55 x 0.3	85.6 x 54 x 0.9	85.6 x 54 x 0.8	85.6 x 54 x 0.8	Ø 10 x 4.5	Ø 10 x 4.5	Ø 20 x 6	Ø 20 x 6	Ø 18 x 5.2	Ø 30 x 8	Ø 27 x 4	Ø 27 x 4	Ø 27 x 4	Ø 27 x 4	Ø 27 x 10	Ø 24 x 10	Ø 50 x 3.6	
	Page	2/8	2/8	2/10	2/12	2/14	2/16	2/18	2/20	2/22	2/22	2/24	2/26	2/28	2/30	2/32	2/34	2/36	2/38	
RF200 reader	2/78																			
RF210R	2/79	-	-	-	-	-	0 ... 3	0 ... 3	1 ... 9	1 ... 8	1 ... 8	2 ... 10	1 ... 18	1 ... 8	1 ... 16	1 ... 15	1 ... 6	-	-	
RF220R	2/83	5 ... 36	5 ... 30	1 ... 35	5 ... 35	-	1 ... 5	1 ... 5	1 ... 12	1 ... 10	1 ... 10	2 ... 24	1 ... 28	2 ... 21	2 ... 25	2 ... 22	1 ... 11	-	2 ... 30	
RF240R	2/86	2 ... 80	2 ... 60	2 ... 84	2 ... 69	2 ... 80	-	-	1 ... 12	1 ... 10	1 ... 10	2 ... 35	2 ... 53	1 ... 36	1 ... 47	1 ... 45	1 ... 15	-	2 ... 57	
RF250R with ANT 3	2/90	-	-	-	-	-	-	-	1 ... 12	1 ... 12	1 ... 12	0 ... 24	2 ... 32	2 ... 32	0 ... 45	1 ... 30	0 ... 16	-	-	
RF250R with ANT 3S	2/90	-	-	-	-	-	0 ... 3	0 ... 3	-	-	-	-	-	-	-	-	-	-	-	
RF250R with ANT 8	2/90	-	-	-	-	-	0 ... 3	0 ... 3	-	-	-	-	-	-	-	1 ... 8	-	-	-	
RF250R with ANT 12	2/90	-	-	-	-	-	0 ... 3	0 ... 3	0 ... 7	1 ... 7	1 ... 7	-	-	1 ... 10	-	1 ... 15	0 ... 8	-	-	
RF250R with ANT 18	2/90	-	-	-	-	-	0 ... 3	0 ... 4	1 ... 8	1 ... 10	1 ... 10	1 ... 15	0 ... 24	1 ... 18	1 ... 27	1 ... 25	1 ... 11	-	-	
RF250R with ANT 30	2/90	1 ... 45	1 ... 40	1 ... 50	1 ... 45	1 ... 42	-	-	0 ... 12	1 ... 12	1 ... 12	0 ... 18	1 ... 35	1 ... 22	0 ... 34	1 ... 35	1 ... 12	-	0 ... 47	
RF260R	2/95	2 ... 120	2 ... 75	2 ... 110	2 ... 100	2 ... 110	-	-	-	-	-	2 ... 40	2 ... 80	2 ... 60	2 ... 60	2 ... 60	-	-	2 ... 75	
RF290R with ANT D1	2/99	10 ... 180	-	10 ... 180	10 ... 170	10 ... 170	-	-	-	-	20 ... 25	20 ... 25	10 ... 55	0 ... 100	0 ... 90	0 ... 90	0 ... 90	-	-	5 ... 110
RF290R with ANT D5	2/99	0 ... 350	0 ... 300	0 ... 400	0 ... 400	0 ... 400	-	-	-	-	-	-	0 ... 200	0 ... 200	0 ... 200	0 ... 200	-	-	0 ... 350	
RF290R with ANT D6	2/99	0 ... 400	0 ... 350	0 ... 550	0 ... 500	0 ... 500	-	-	-	-	-	-	0 ... 220	0 ... 200	0 ... 220	0 ... 220	-	-	0 ... 400	
RF290R with ANT D10	2/99	0 ... 350	0 ... 350	0 ... 500	0 ... 450	0 ... 400	-	-	-	-	-	-	0 ... 200	0 ... 200	0 ... 200	0 ... 220	-	-	0 ... 400	
RF300 reader	2/104																			
RF310R	2/105	2 ... 90	2 ... 74	2 ... 93	2 ... 84	2 ... 104	-	-	-	-	-	2 ... 35	2 ... 64	2 ... 47	1 ... 70	-	1 ... 22	-	2 ... 65	
RF340R	2/107	5 ... 100	5 ... 60	5 ... 110	5 ... 80	2 ... 100	-	-	-	-	-	2 ... 40	2 ... 60	2 ... 55	2 ... 55	-	2 ... 18	-	2 ... 85	
RF350R with ANT 1	2/109	5 ... 100	5 ... 80	5 ... 110	5 ... 95	2 ... 110	-	-	-	-	-	2 ... 50	2 ... 65	2 ... 70	2 ... 60	-	2 ... 23	-	2 ... 90	
RF350R with ANT 3	2/109	-	-	-	-	-	-	-	1 ... 12	-	-	0 ... 25	0 ... 35	2 ... 32	0 ... 42	-	0 ... 16	-	-	
RF350R with ANT 3S	2/109	-	-	-	-	-	0 ... 4	-	-	-	-	-	-	-	-	-	-	-	-	
RF350R with ANT 12	2/109	-	-	-	-	-	0 ... 3	-	-	-	-	-	-	-	-	-	-	-	-	
RF350R with ANT 18	2/109	-	-	-	-	-	0 ... 6	-	1 ... 10	-	-	-	2 ... 24	1 ... 22	1 ... 27	-	1 ... 9	-	-	
RF350R with ANT 30	2/109	1 ... 45	1 ... 40	1 ... 50	1 ... 45	-	-	-	0 ... 15	-	-	2 ... 30	1 ... 35	1 ... 35	0 ... 45	-	1 ... 14	-	0 ... 47	
RF380R	2/112	5 ... 170	5 ... 120	5 ... 170	5 ... 150	2 ... 200	-	-	-	-	-	5 ... 75	1 ... 120	2 ... 96	2 ... 120	-	2 ... 32	-	2 ... 145	
RF382R	2/115	-	-	-	-	-	-	-	-	-	-	-	40 ... 65	40 ... 65	40 ... 65	-	-	-	-	
MOBY D reader	2/122																			
SLG D11 / SLG D11S with ANT D2	2/123	-	-	-	-	-	-	-	-	-	-	-	45 ... 70	35 ... 60	45 ... 70	-	-	-	-	
SLG D11 / SLG D11S with ANT D5	2/123	0 ... 220	0 ... 200	0 ... 300	0 ... 220	0 ... 240	-	-	-	-	-	-	0 ... 150	0 ... 120	0 ... 150	-	-	-	0 ... 200	
SLG D12 / SLG D12S	2/126	0 ... 120	0 ... 100	0 ... 160	0 ... 120	0 ... 100	-	-	-	-	-	-	0 ... 70	0 ... 60	0 ... 70	-	-	-	0 ... 100	

- Reader-transponder combination not released.

Overview

MDS D426 6GT2600-4AH00	MDS D526 6GT2600-5AH00	MDS D117 6GT2600-0AG00	MDS D127 6GT2600-0AF00	MDS D428 6GT2600-4AK00-0AX0	MDS D528 6GT2600-5AK00	MDS D139 6GT2600-0AA10	MDS D339 6GT2600-3AA10	MDS D160 6GT2600-0AB10	MDS D460 6GT2600-4AB00	RF320T 6GT2800-1CA00	RF330T 6GT2800-5BA00	RF340T 6GT2800-4BB00	RF350T 6GT2800-5BD00	RF360T 6GT2800-4AC00	RF370T 6GT2800-5BE00 (32Kb) 6BE00 (64Kb)	RF380T 6GT2800-5DA00	Transponder Article No.	Operating distance (mm) between transponder and reader
2 Kbyte	8 kbyte	112 byte	112 byte	2 kbyte	8 kbyte	112 byte	992 byte	112 byte	2 kbyte	20 byte	32 kbyte	8 kbyte	32 kbyte	8 kbyte	32 / 64 kbyte	32 kbyte	User memory	
-40 °C ... 100 °C	-40 °C ... 100 °C	-40 °C ... 125 °C	-40 °C ... 125 °C	-40 °C ... 125 °C	-40 °C ... 125 °C	-40 °C ... 220 °C	-40 °C ... 220 °C	-40 °C ... 175 °C	-40 °C ... 100 °C	-40 °C ... 140 °C	-40 °C ... 100 °C	-40 °C ... 85 °C	-40 °C ... 85 °C	-40 °C ... 85 °C	-40 °C ... 85 °C	-40 °C ... 220 °C	Temperature range	
∅ 50 x 3.6	∅ 50 x 3.6	∅ 4 x 5	∅ 6 x 5	∅ 18 x 20	∅ 24 x 20	∅ 85 x 15	∅ 85 x 15	∅ 16 x 3	∅ 16 x 3	∅ 27 x 4	∅ 30 x 8	48 x 25 x 15	50 x 50 x 20	85.8 x 54.1 x 2.5	75 x 75 x 41	∅ 114 x 83	L x W x H or ∅ x H (mm)	
2/40	2/42	2/44	2/46	2/48	2/50	2/52	2/54	2/56	2/58	2/61	2/63	2/65	2/67	2/69	2/71	2/73	Page	
-	-	-	0 ... 2	1 ... 10	1 ... 10	-	-	1 ... 10	1 ... 8	-	-	-	-	-	-	-	2/78	RF200 reader
2 ... 25	2 ... 25	-	-	1 ... 18	1 ... 15	5 ... 35	2 ... 15	1 ... 20	1 ... 18	-	-	-	-	-	-	-	2/79	RF210R
2 ... 45	2 ... 45	-	-	1 ... 30	1 ... 30	5 ... 77	0 ... 35	1 ... 33	1 ... 30	-	-	-	-	-	-	-	2/83	RF220R
-	2 ... 35	-	-	0 ... 25	1 ... 20	-	-	1 ... 16	0 ... 18	-	-	-	-	-	-	-	2/86	RF240R
-	-	0 ... 2	0 ... 2	-	-	-	-	-	-	-	-	-	-	-	-	-	2/90	RF250R with ANT 3
-	-	0 ... 2	0 ... 3	-	-	-	-	-	-	-	-	-	-	-	-	-	2/90	RF250R with ANT 3S
-	-	0 ... 3	0 ... 4	1 ... 8	1 ... 8	-	-	0 ... 12	1 ... 10	-	-	-	-	-	-	-	2/90	RF250R with ANT 8
-	-	-	-	1 ... 18	1 ... 15	-	-	1 ... 18	1 ... 17	-	-	-	-	-	-	-	2/90	RF250R with ANT 12
0 ... 44	2 ... 35	-	-	1 ... 20	1 ... 20	1 ... 42	1 ... 42	1 ... 23	1 ... 21	-	-	-	-	-	-	-	2/90	RF250R with ANT 18
2 ... 70	2 ... 70	-	-	2 ... 40	2 ... 35	2 ... 80	5 ... 65	2 ... 40	2 ... 40	-	-	-	-	-	-	-	2/90	RF250R with ANT 30
5 ... 100	5 ... 100	-	-	0 ... 55	0 ... 55	5 ... 160	5 ... 130	0 ... 65	0 ... 60	-	-	-	-	-	-	-	2/95	RF260R
0 ... 300	0 ... 300	-	-	-	-	0 ... 400	0 ... 300	0 ... 130	0 ... 120	-	-	-	-	-	-	-	2/99	RF290R with ANT D1
0 ... 350	0 ... 350	-	-	-	-	0 ... 500	0 ... 400	0 ... 130	-	-	-	-	-	-	-	-	2/99	RF290R with ANT D5
0 ... 350	0 ... 350	-	-	-	-	0 ... 450	0 ... 300	0 ... 130	-	-	-	-	-	-	-	-	2/99	RF290R with ANT D6
-	-	-	-	-	-	0 ... 450	0 ... 300	0 ... 130	-	-	-	-	-	-	-	-	2/99	RF290R with ANT D10
5 ... 100	-	-	-	1 ... 43	-	5 ... 96	5 ... 74	1 ... 39	1 ... 37	1 ... 23	0 ... 5	2 ... 36	2 ... 47	2 ... 60	-	-	2/104	RF300 reader
0 ... 80	-	-	-	2 ... 35	-	5 ... 80	5 ... 75	2 ... 35	2 ... 25	1 ... 20	-	2 ... 50	2 ... 60	2 ... 65	5 ... 60	5 ... 80	2/105	RF310R
0 ... 85	-	-	-	2 ... 35	-	5 ... 85	5 ... 90	2 ... 35	2 ... 35	1 ... 30	-	2 ... 55	2 ... 65	2 ... 75	5 ... 65	5 ... 90	2/107	RF340R
-	-	-	-	0 ... 25	-	5 ... 85	-	1 ... 16	0 ... 18	1 ... 16	1 ... 12	2 ... 32	2 ... 35	2 ... 40	-	-	2/109	RF350R with ANT 1
-	-	0 ... 2	0 ... 2	-	-	-	-	-	-	-	-	-	-	-	-	-	2/109	RF350R with ANT 3
-	-	0 ... 3	0 ... 3	1 ... 10	-	-	-	0 ... 8	1 ... 10	-	0 ... 4	-	-	1 ... 5	-	-	2/109	RF350R with ANT 3S
-	-	1 ... 3	0 ... 4	1 ... 12	-	-	-	1 ... 18	1 ... 12	0 ... 10	0 ... 10	0 ... 20	-	2 ... 15	-	-	2/109	RF350R with ANT 12
0 ... 45	-	-	-	1 ... 25	-	-	-	1 ... 25	1 ... 18	0 ... 15	2 ... 13	0 ... 30	0 ... 35	2 ... 25	-	-	2/109	RF350R with ANT 18
0 ... 155	-	-	-	2 ... 70	-	5 ... 160	5 ... 160	2 ... 64	2 ... 65	2 ... 45	-	2 ... 80	2 ... 100	2 ... 120	5 ... 100	5 ... 125	2/112	RF380R
-	-	-	-	-	-	-	-	35 ... 50	30 ... 50	-	-	-	-	-	-	-	2/115	RF382R
-	-	-	-	-	-	-	-	35 ... 55	35 ... 50	-	-	-	-	-	-	-	2/122	MOBY D reader
-	-	-	-	0 ... 70	-	0 ... 280	-	0 ... 75	0 ... 70	-	-	-	-	-	-	-	2/123	SLG D11 / SLG D11S with ANT D2
-	-	-	-	0 ... 40	-	0 ... 120	-	0 ... 45	0 ... 40	-	-	-	-	-	-	-	2/123	SLG D11 / SLG D11S with ANT D5
-	-	-	-	-	-	-	-	-	-	-	-	-	-	-	-	-	2/126	SLG D12 / SLG D12S















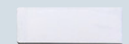

SIMATIC Ident

RFID systems field data table

1

Overview

UHF range (RF600)

Maximum read distance (m)	Transponder Article No.	RF622L 6GT2810-4AC80	RF630L 6GT2810-2AB00	RF630L 6GT2810-2AB01	RF630L 6GT2810-2AE81-0AX1	RF630L 6GT2810-2AB02-0AX0	RF630L 6GT2810-2AB03	RF640L 6GT2810-2AC00 6GT2810-2AC10	RF680L 6GT2810-2AG80	RF690L 6GT2810-2AG00 6GT2810-2AG10	RF610T 6GT2810-2BB80 6GT2810-2BB80-0AX1	RF620T 6GT2810-2HC81	RF622T 6GT2810-4HC80	RF625T 6GT2810-2EE00 6GT2810-2EE01	RF630T 6GT2810-2EC00 6GT2810-2EC10	RF640T 6GT2810-2DC00 6GT2810-2DC10	RF680T 6GT2810-2HG80	
																		
EPC ID memory		62 byte	12 byte	12 byte	16 byte	16 byte	30 byte	12/60 byte	30 byte	12/60 byte	30 byte	16 byte	62 byte	16 byte	30 byte	30 byte	30 byte	
User memory		3 424 byte	12 byte	12 byte	16 byte	64 byte	64 byte	64/16 byte	64 byte	64/16 byte	64 byte	64 byte	3 424 byte	64 byte	64 byte	64 byte	64 byte	
L x W x H or Ø x H (mm)		90 x 18 x 0.5	101 x 152 x 0.3	101 x 50 x 0.3	90 x 30 x 0.3	27 x 97 x 0.3	34 x 54 x 0.3	50 x 22 x 1.6	54 x 86 x 0.4	88 x 25 x 1.6	54 x 86 x 0.4	127 x 38 x 6	120 x 30 x 6.5	Ø 30 x 8	Ø 30 x 8	Ø 50 x 8	32 x 130 x 15	
Frequency range MHz		860 – 960	860 – 960	860 – 960	860 – 960	860 – 960	860 – 960	860 – 868 902 – 928	860 – 960	860 – 868 902 – 928	860 – 960	860 – 960	860 – 960	860 – 868 902 – 928	860 – 868 902 – 928	860 – 868 902 – 928	860 – 960	
	Page	3/5	3/6	3/6	3/6	3/6	3/6	3/9	3/11	3/12	3/14	3/16	3/18	3/18	3/20	3/22	3/24	3/26

Metal-free surface With spacer on metal

<i>RF650R reader</i>																		
RF650R with RF620A	3/30	0.4	0.95	0.95	0.6	0.95	0.6	0.35	0.6	0.6	0.6	0.6	0.4	0.2	0.6	0.3	0.6	0.6
RF650R with RF640A	3/30	2.5	4.6	4.6	2.3	4.6	3.0	2.0	2.3	2.3	3.0	4.6	2.5	0.7	4.6	1.5	3.0	3.0
RF650R with RF642A	3/30	3.0	8.0	8.0	4.0	8.0	5.0	2.5	4.0	4.0	5.0	8.0	3.0	1.0	8.0	2.0	4.0	4.0
RF650R with RF660A	3/30	3.0	8.0	8.0	4.0	8.0	5.0	3.5	4.0	4.0	5.0	8.0	3.0	0.9	8.0	2.0	4.0	4.0
<i>RF680R reader</i>																		
RF680R with RF620A	3/33	0.4	1.35	1.35	0.85	1.35	0.85	0.35	0.85	0.7	0.85	0.85	0.4	0.2	0.5	0.4	0.9	0.9
RF680R with RF640A	3/33	2.5	6.0	6.0	3.0	6.0	4.0	2.0	3.0	3.0	4.0	6.0	2.5	0.7	1.2	2.0	4.0	4.0
RF680R with RF642A	3/33	3.0	8.0	8.0	4.0	8.0	5.0	2.5	4.0	4.5	5.0	8.0	3.0	1.0	1.5	2.0	4.0	4.0
RF680R with RF660A	3/33	3.0	8.0	8.0	4.0	8.0	5.0	3.5	4.0	5.0	5.0	8.0	3.0	0.9	1.5	2.0	4.0	4.0
<i>RF685R reader</i>																		
RF685R with internal antenna	3/37	3.0	7.0	7.0	3.5	7.0	4.0	3.0	3.5	4.0	4.5	7.0	3.0	0.9	1.5	2.0	4.0	4.0
RF685R with RF620A	3/37	0.4	1.35	1.35	0.85	1.35	0.85	0.35	0.85	0.7	0.85	0.85	0.4	0.2	0.5	0.4	0.9	0.9
RF685R with RF640A	3/37	2.5	6.0	6.0	3.0	6.0	4.0	2.0	3.0	3.0	4.0	6.0	2.5	0.7	1.2	2.0	4.0	4.0
RF685R with RF642A	3/37	3.0	8.0	8.0	4.0	8.0	5.0	2.5	4.0	4.5	5.0	8.0	3.0	1.0	1.5	2.0	4.0	4.0
RF685R with RF660A	3/37	3.0	8.0	8.0	4.0	8.0	5.0	3.5	4.0	5.0	5.0	8.0	3.0	0.9	1.5	2.0	4.0	4.0

RFID systems for the HF range

**2/2 Introduction****2/4 Transponders (ISO mode)**

2/4	Introduction
2/8	MDS D165
2/8	MDS D261
2/10	MDS D100
2/12	MDS D200
2/14	MDS D400
2/16	MDS D421
2/18	MDS D521
2/20	MDS D422
2/22	MDS D522
2/24	MDS D423
2/26	MDS D124
2/28	MDS D324
2/30	MDS D424
2/32	MDS D524
2/34	MDS D425
2/36	MDS D525
2/38	MDS D126
2/40	MDS D426
2/42	MDS D526
2/44	MDS D117
2/46	MDS D127
2/48	MDS D428
2/50	MDS D528
2/52	MDS D139
2/54	MDS D339
2/56	MDS D160
2/58	MDS D460

2/60 Transponders (RF300 mode)

2/60	Introduction
2/61	RF320T
2/63	RF330T
2/65	RF340T
2/67	RF350T
2/69	RF360T
2/71	RF370T
2/73	RF380T

2/76 RF200

2/78	RF200 readers
2/79	RF210R
2/82	RF210M mobile handheld terminal
2/83	RF220R
2/86	RF240R
2/90	RF250R
2/95	RF260R
2/99	RF290R
2/117	RF350M mobile handheld terminal

2/102 RF300

2/104	RF300 readers
2/105	RF310R
2/107	RF340R
2/109	RF350R
2/112	RF380R
2/115	RF382R
2/117	RF350M mobile handheld terminal

2/120 MOBY D

2/122	MOBY D readers
2/123	SLG D11 / SLG D11S basic units
2/126	SLG D12 / SLG D12S
2/129	MOBY D Configuring instructions

2/130 HF antennas

2/130	Introduction
2/131	ANT 1 for RF350R
2/132	ANT 3 for RF250R, RF350R and RF350M
2/133	ANT 3S for RF250R, RF350R and RF350M
2/134	ANT 8 for RF250R and RF350M
2/136	ANT 12 for RF250R, RF350R and RF350M
2/137	ANT 18 for RF250R, RF350R and RF350M
2/138	ANT 30 for RF250R, RF350R and RF350M
2/139	ANT D1 for RF290R
2/140	ANT D2 for SLG D11 / SLG D11S
2/141	ANT D5 for RF290R and SLG D11 / D11S
2/143	ANT D6 for RF290R
2/145	ANT D10 for RF290R

RFID systems for the HF range

Introduction

Overview



As the world's leading supplier of identification systems, with SIMATIC Ident Siemens offers a unique integrated and scalable range of RFID and optical identification systems for flexible and cost-effective identification solutions.

RFID systems are offered for the most diverse requirements on performance, range, frequency range as well as HF and UHF. This section provides you an overview of our RFID systems in the HF range.

Easy integration of the RFID systems via communication modules and pre-configured software blocks in the world of Totally Integrated Automation (TIA) significantly reduces the work and costs necessary for commissioning, diagnostics and maintenance. Thanks to many years of experience in the area of RFID, Siemens is a competent partner for implementation of the most diverse solutions in all sectors, but especially in the areas of production and logistics.

RFID systems for the HF frequency range

Siemens offers the following two RFID systems for the HF range:

- **SIMATIC RF200:**
The compact and economical RFID system according to ISO 15693. Readers with an IO-Link interface are provided for particularly simple and open identification solutions.
- **SIMATIC RF300:**
For the most demanding requirements in terms of speed, data volume and diagnostics functionality, the RF300 mode with separate transponders is available. The high-performance RFID system can be operated with ISO 15693 transponders to meet average performance requirements.

Meaningful data from the outset

The RFID systems ensure that meaningful data accompanies a product or object from the very beginning. The transponders are attached to the product, product carrier, object or its transport or packing unit and are recorded, read and written by non-contact methods. This means that all the application-specific data is located on the transponder. This is true whether you are dealing with vehicle body parts in the automotive industry or order picking boxes. Up to 64 KB of data can be stored and individually read and supplemented when required at the various workstations or manufacturing stations. This all means that the flow of material and data is synchronized optimally.

Contactless data transfer and a high degree of industrial compatibility

Powerful readers (write/read devices) in various rugged designs ensure fast and reliable data transfer between the transponders and the higher-level systems (e.g. PLC, PC).

The data and power are transmitted inductively by an electromagnetic alternating field. This principle of contactless data transfer also works in the presence of contamination or through numerous non-metallic materials.

Perfectly matched components

The RFID systems consist of perfectly matched individual components:

- Transponder
- Readers
- Antennas
- Communication modules for connection to the automation system (e.g. PROFIBUS, PROFINET)
- Software for system integration

For a wide range of applications in all sectors

- Production control
- Asset management
- Tracking & tracing

Wide range of transponders

A wide range of different transponders is available using a variety of storage technologies and geometric designs. Their strength is not only their high level of data security but also the excellent high degree of protection against ambient conditions such as contamination, temperature fluctuations, washing water or shock load.

Benefits



- Flexible and economic solutions thanks to the complete and scalable portfolio for the field of industrial identification.
- Simplified engineering, commissioning, diagnostics and maintenance through seamless integration into Totally Integrated Automation:
 - Integrated bus connection to an automation system, such as SIMATIC, SIMOTION or SINUMERIK via communication modules with PROFIBUS and PROFINET.
 - Simple S7 software integration via ready-to-use function blocks.
 - Extensive status and diagnostic functions.
- High degree of investment protection thanks to:
 - Open standards (e.g. ISO 15693).
 - Software compatibility between the RFID and optical reading systems of Siemens.
 - Standardized communication interfaces.
- Openness through connection possibilities to different bus systems from different manufacturers and PC environments via communication modules.
- Worldwide Service and Support.

Integration

A wide range of communication modules, function blocks, as well as high-performance drivers and function libraries permits easy and quick integration into the application. And best of all: SIMATIC RF is part of Totally Integrated Automation (TIA) and can be integrated easily and cost-effectively into the SIMATIC world. For more details on the connection possibilities, see the section "Communication Modules".

SIMATIC Ident Configuration Guide

Here is a compact configuration tool for setting up RFID systems:

<http://support.automation.siemens.com/WW/view/en/67384964>











RFID systems for the HF range











Transponders (ISO mode)

Introduction

Overview

The following transponders can be used with the SIMATIC RF200, RF300 or MOBY D RFID systems:

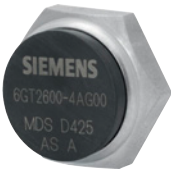
Transponder	Features	Page	Transponder	Features	Page
 MDS D165	SmartLabel, (PET) similar to credit card format. Applications range from simple identification such as electronic barcode substitution or supplementation, to storage and distribution logistics, right up to product identification.. Usable for RFID systems: <ul style="list-style-type: none"> • RF200 • RF300 • MOBY D 	2/8	 MDS D421	Transponder for the tool coding according to DIN 69873. It can be used wherever very small data media and exact positioning are required (e.g. for tool identification). Usable for RFID systems: <ul style="list-style-type: none"> • RF200 • RF300 • MOBY D 	2/16
 MDS D261	SmartLabel, (PET) in compact design. Applications range from simple identification such as electronic barcode substitution or supplementation, to storage and distribution logistics, right up to product identification. Usable for RFID systems: <ul style="list-style-type: none"> • RF200 • RF300 • MOBY D 	2/8	 MDS D521	The MDS D521 is designed for tool coding according to DIN 69873. Usable for RFID systems: <ul style="list-style-type: none"> • RF200 	2/18
 MDS D100	Universal transponder in credit card format with 112 bytes EEPROM, suitable for the identification of transport units in production-related logistics. Usable for RFID systems: <ul style="list-style-type: none"> • RF200 • RF300 • MOBY D 	2/10	 MDS D422	Transponder for the identification of metallic workpiece holders, workpieces or containers. Usable for RFID systems: <ul style="list-style-type: none"> • RF200 • RF300 	2/20
 MDS D200	Universal transponder in credit card format with 256 bytes EEPROM, suitable for the identification of transport units in production-related logistics. Usable for RFID systems: <ul style="list-style-type: none"> • RF200 • RF300 • MOBY D 	2/12	  MDS D522	Transponder for the identification of metallic workpiece holders, workpieces or containers. Usable for RFID systems: <ul style="list-style-type: none"> • RF200 	2/22
 MDS D400	Universal transponder in credit card format with 2 000 bytes FRAM, suitable for the identification of transport units in production-related logistics. Usable for RFID systems: <ul style="list-style-type: none"> • RF200 • RF300 • MOBY D 	2/14	 MDS D423	Rugged transponder for use in production and distribution logistics as well as in assembly and production lines. Usable for RFID systems: <ul style="list-style-type: none"> • RF200 • RF300 	2/24

Transponder	Features	Page	Transponder	Features	Page
MDS D124 	Heat-resistant transponder for use in applications with high thermal stress. Usable for RFID systems: <ul style="list-style-type: none"> • RF200 • RF300 • MOBY D 	2/26	MDS D525 	It is designed for use in assembly and production lines as well as in the powertrain sector. Usable for RFID systems: <ul style="list-style-type: none"> • RF200 	2/36
MDS D324 	Rugged transponder for use in harsh industrial environments and under extreme environmental conditions. Usable for RFID systems: <ul style="list-style-type: none"> • RF200 • RF300 • MOBY D 	2/28	MDS D126 	Compact and rugged transponder for identification of transport units in production-related logistics. The transponder can also be used in harsh environments. Usable for RFID systems: <ul style="list-style-type: none"> • RF200 • RF300 • MOBY D 	2/38
MDS D424 	Rugged transponder for use in production and distribution logistics as well as in assembly and production lines. Usable for RFID systems: <ul style="list-style-type: none"> • RF200 • RF300 • MOBY D 	2/30	MDS D426 	Compact and rugged transponder for identification of transport units in production-related logistics. The transponder can also be used in harsh environments. Usable for RFID systems: <ul style="list-style-type: none"> • RF200 • RF300 • MOBY D 	2/40
MDS D524 	The transponder is designed for use in production and distribution logistics as well as in assembly and production lines. Usable for RFID systems: <ul style="list-style-type: none"> • RF200 	2/32	MDS D526 	It is designed for the identification of transport units in production-related logistics. Usable for RFID systems: <ul style="list-style-type: none"> • RF200 	2/42
MDS D425 	Compact and rugged transponder suitable for screw mounting. For use in assembly and production lines in the powertrain sector. Usable for RFID systems: <ul style="list-style-type: none"> • RF200 • RF300 	2/34	MDS D117 	Extremely small, ISO-15693-compatible transponder that can be flush-mounted on metal with adhesive. Transponder for direct identification of metallic workpiece holders, small workpieces, or containers. Usable for RFID systems: <ul style="list-style-type: none"> • RF200 • RF300 	2/44

RFID systems for the HF range

Transponders (ISO mode)

Introduction

Transponder	Features	Page	Transponder	Features	Page
MDS D127 	<p>Extremely small, ISO 15693-compatible transponder that can be screwed flush into metal.</p> <p>Transponder for direct identification of metallic workpiece holders, small workpieces, or containers</p> <p>Usable for RFID systems:</p> <ul style="list-style-type: none"> • RF200 • RF300 	2/46	MDS D160 	<p>Special transponder for harsh environments in the laundry and cleaning industry.</p> <p>Usable for RFID systems:</p> <ul style="list-style-type: none"> • RF200 • RF300 • MOBY D 	2/56
MDS D428 	<p>Compact and rugged transponder for screw mounting; for use in assembly and production lines in the powertrain area.</p> <p>Usable for RFID systems:</p> <ul style="list-style-type: none"> • RF200 • RF300 • MOBY D 	2/48	MDS D460 	<p>Rugged transponder for use in assembly lines.</p> <p>Usable for RFID systems:</p> <ul style="list-style-type: none"> • RF200 • RF300 • MOBY D 	2/58
MDS D528 	<p>It is designed for use in assembly and production lines as well as in the powertrain sector.</p> <p>Usable for RFID systems:</p> <ul style="list-style-type: none"> • RF200 	2/50	<p>Customer-specific transponders</p> <p>Customer-specific transponders (packaging, temperature range, geometry, etc.) on request.</p>		
MDS D139 	<p>Heat-resistant transponder for use in paint shops or applications with high thermal stress.</p> <p>Usable for RFID systems:</p> <ul style="list-style-type: none"> • RF200 • RF300 • MOBY D 	2/52			
MDS D339 	<p>Heat-resistant transponder for use in paint shops or applications with high thermal stress..</p> <p>Usable for RFID systems:</p> <ul style="list-style-type: none"> • RF200 • RF300 • MOBY D 	2/54			

Benefits

The comprehensive portfolio of ISO 15693 transponders offers the right solution for every requirement in production and production logistics:

- Large memory of up to 8 192 bytes (FRAM)
- Low-cost transponders can, if necessary, be mounted on metal with a spacer.
- Extremely rugged transponder for high temperature ranges up to 220 °C with ATEX approval for use in paint shops.
- Extremely small transponder for exact positioning, e.g. for tool identification.
- Screw-fit transponders for automatic attachment by means of robots.
- Screw-fit transponders for flush-mounting in metal for identifying workpieces or workpiece holders.
- Customized solutions for SmartLabels and transponders on request.

Technical specifications***Field data (operating/limit distance) of transponders and readers (all specifications in mm)***

The the field data (unaffected by metal) for all ISO transponders (MDS Dxxx) in connection with RF200 readers is listed in the technical specifications of the RFID overview. The listed technical data are typical values and are valid for a room temperature of +25 °C.

RFID systems for the HF range

Transponder (ISO mode)

MDS D165/D261

Overview

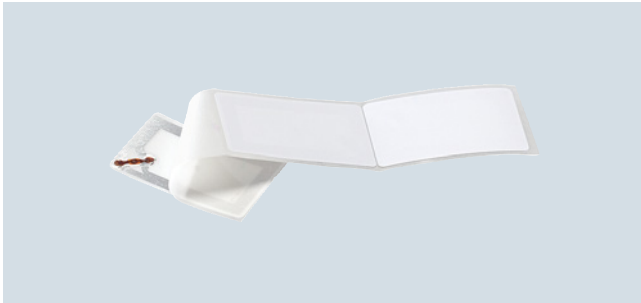

The SmartLabels MDS D165 and MDS D261 can be used for the RFID system MOBY D as well as for SIMATIC RF200 and SIMATIC RF300 (ISO mode).

SmartLabels permit numerous flexible constructions to ensure optimum dimensioning for many different applications.

Thanks to their very reasonable price, the SmartLabels can be used universally as "electronic barcode substitutes or supplements" or "delivery notes".



6GT2600-1AB00-0AX0¹⁾

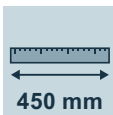

6GT2600-1AA01-0AX0

Technical specifications

Article number	6GT2600-1AB00-0AX0	6GT2600-1AA01-0AX0
Product type designation	MDS D165 SmartLabel	MDS D261 SmartLabel
Suitability for operation	RF200, RF300, MOBY D	RF200, RF300, MOBY D
Wireless frequencies		
Operating frequency Rated value	13.56 MHz	13.56 MHz
Electrical data		
Range maximum	500 mm range is reader dependent: observe http://support.automation.siemens.com/WW/view/en/67384964	450 mm
Protocol with radio transmission	ISO 15693	ISO 15693
Transfer rate with radio transmission maximum	26.5 kbit/s	26.5 kbit/s
Product feature multitag-capable	Yes	Yes
Product component Backup battery	No	No
Memory		
Type of memory	EEPROM	EEPROM
Storage capacity of the user memory	112 byte	256 byte
Type of memory organization	UID (fixed code) 8 bytes, user memory 112 bytes, configuration memory 8 bytes	UID (fixed code) 8 bytes, user memory 256 bytes, configuration memory 8 bytes
Number of read cycles at ambient temperature < 40 °C maximum	100 000 000 000 000	100 000 000 000 000
Number of write cycles at ambient temperature < 40 °C maximum	1 000 000	1 000 000
Data retention time at ambient temperature < 40 °C not less than	10 y	10 y
Property of memory	Block-by-block write protection of the user memory	Block-by-block write protection of the user memory
Type of transponder chip used	NXP I-Code SLI	STM LRI2K
Mechanical data		
Material	Top side + inlay: PET, antenna aluminum	Top side + inlay: PET, antenna aluminum
Color	white	white
Mounting distance relating to metal surfaces recommended minimum	25 mm	25 mm

¹⁾ Explanation of symbols: See page 1/8.

RFID systems for the HF range

Transponder (ISO mode)

MDS D165/D261

	6GT2600-1AB00-0AX0	6GT2600-1AA01-0AX0
Article number	MDS D165 SmartLabel	MDS D261 SmartLabel
Product type designation	RF200, RF300, MOBY D	RF200, RF300, MOBY D
Suitability for operation		
Permitted ambient conditions		
Ambient temperature		
• during read/write access	-25 ... +85 °C	-25 ... +85 °C
• outside the read/write area	-25 ... +85 °C	-25 ... +85 °C
• during storage	20 ... 30 °C	20 ... 30 °C
Protection class IP	IP65	IP65
Resistance to mechanical stress	Maximum storage period: 2 years (determined by durability of the adhesive)	Maximum storage period: 2 years (determined by durability of the adhesive)
Design, dimensions and weight		
Width	54 mm	55 mm
Height	0.3 mm	0.3 mm
Depth	86 mm	55 mm
Net weight	1 g	1 g
Mounting type	one-side adhesible	one-side adhesible
Product properties, functions, components general		
Product feature		
• printable	Yes	Yes
Printing process	Thermal transfer process	Thermal transfer process

Selection and ordering data

	Article No.
MDS D165 SmartLabel	6GT2600-1AB00-0AX0
112 bytes EEPROM	
Ordering quantity 1 000 units or a multiple thereof.	
MDS D261 SmartLabel	6GT2600-1AA01-0AX0
256 bytes EEPROM	
Ordering quantity 1 000 units or a multiple thereof.	

RFID systems for the HF range

Transponder (ISO mode)

MDS D100

Overview

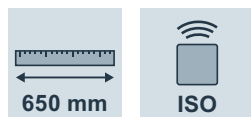
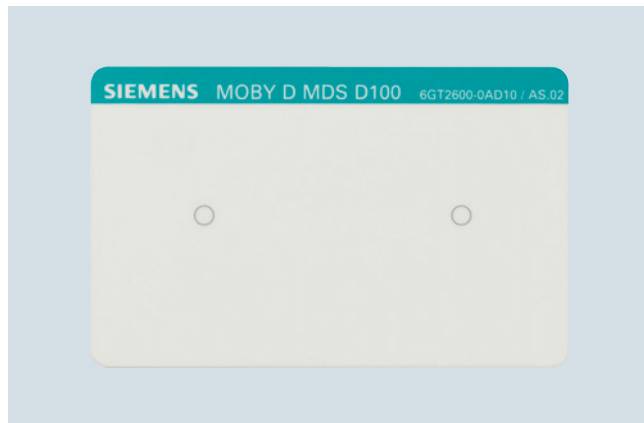

The transponder in credit card format can be used for the RFID system MOBY D as well as for SIMATIC RF200 and SIMATIC RF300 (ISO mode).

Application



Applications range from simple identification such as electronic bar code substitution or supplementation, to storage and distribution logistics, up to product identification.

This transponder can even be used problem-free under extreme environmental conditions (e.g. when subjected to temperatures up to +80 °C).

Technical specifications

Article number	6GT2600-0AD10
Product type designation	MDS D100 transponder
Suitability for operation	RF200, RF300, MOBY D
Wireless frequencies	
Operating frequency Rated value	13.56 MHz
Electrical data	
Range maximum	650 mm; range is reader dependent: observe http://support.automation.siemens.com/WW/view/en/67384964
Protocol with radio transmission	ISO 15693
Transfer rate with radio transmission maximum	26.5 kbit/s
Product feature multitag-capable	Yes
Product component Backup battery	No
Memory	
Type of memory	EEPROM
Storage capacity of the user memory	112 byte
Type of memory organization	UID (fixed code) 8 bytes, user memory 112 bytes, configuration memory 8 bytes
Number of read cycles at ambient temperature < 40 °C maximum	100 000 000 000 000
Number of write cycles at ambient temperature < 40 °C maximum	1 000 000
Data retention time at ambient temperature < 40 °C not less than	10 y
Property of memory	Block-by-block write protection of the user memory
Type of transponder chip used	NXP I-Code SLI
Mechanical data	
Material	PC laminated plastic
Color	white / petrol
Mounting distance relating to metal surfaces recommended minimum	20 mm
Permitted ambient conditions	
Ambient temperature	
• during read/write access	-25 ... +80 °C
• outside the read/write area	-25 ... +80 °C
• during storage	-25 ... +80 °C
Protection class IP	IP68
Shock resistance	According to DIN EN 60721-3-7 Class 7 M3
Resistance to mechanical stress	Shock and vibration according to ISO 10373 / ISO 7810, torsion and twisting according to ISO 10373 / ISO 7816-3
Design, dimensions and weight	
Width	54 mm
Height	0.9 mm
Depth	85.6 mm
Net weight	5 g
Mounting type	Gluing, mounting bag (see accessories)
Product properties, functions, components general	
Product feature	
• printable	Yes
Printing process	Printable on both sides
Standards, specifications, approvals	
MTBF	228 y
Accessories	
Accessories	Fixing strap, holder, spacer

Selection and ordering data

	Article No.
MDS D100 transponder 112 bytes EEPROM Ordering quantity 50 units or a multiple thereof.	6GT2600-0AD10
<i>Accessories</i>	
Fixing pocket For MDS D100, usable together with spacer 6GT2190-0AA00. Ordering quantity 50 units or a multiple thereof.	6GT2190-0AB00
	
Spacer For fixing pocket (6GT2190-0AB00), thickness 20 mm The purpose of the spacer is to maintain the recommended distance to the metal when installing the transponder. Ordering quantity 50 units or a multiple thereof.	6GT2190-0AA00
	
Holder For MDS D100. Ordering quantity 50 units or a multiple thereof.	6GT2390-0AA00
	

Dimensional drawings

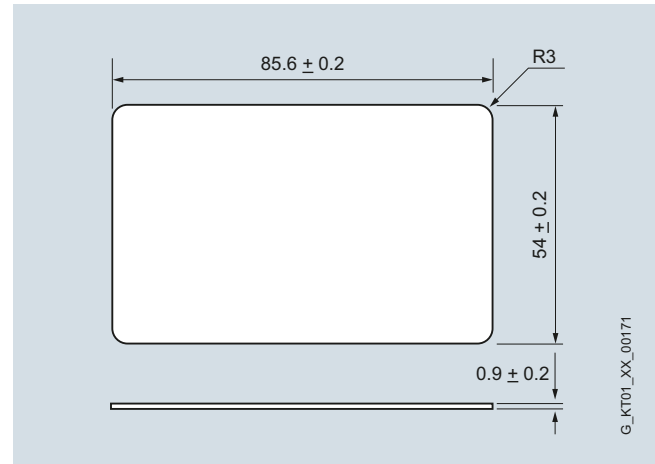

MDS D100 transponder

RFID systems for the HF range

Transponder (ISO mode)

MDS D200

Overview



The MDS D200 is a mobile, passive, maintenance-free transponder based on ISO 15693.

The MDS D200 can be used for the RFID system MOBY D as well as for SIMATIC RF200 and SIMATIC RF300 (ISO mode).

Application



From simple identification, e.g. as electronic barcode replacement or supplementation, through warehouse and distribution logistics, up to product identification.

Technical specifications

Article number	6GT2600-1AD00-0AX0
Product type designation	MDS D200 transponder
Suitability for operation	RF200, RF300, MOBY D
Wireless frequencies	
Operating frequency Rated value	13.56 MHz
Electrical data	
Range maximum	600 mm; range is reader dependent: observe
http://support.automation.siemens.com/WWW/view/en/67384964	
Protocol with radio transmission	ISO 15693
Transfer rate with radio transmission maximum	26.5 kbit/s
Product feature multitag-capable	Yes
Product component Backup battery	No

Article number	6GT2600-1AD00-0AX0
Product type designation	MDS D200 transponder
Suitability for operation	RF200, RF300, MOBY D
Memory	
Type of memory	EEPROM
Storage capacity of the user memory	256 byte
Type of memory organization	UID (fixed code) 8 bytes, user memory 256 bytes, configuration memory 8 bytes
Number of read cycles at ambient temperature < 40 °C maximum	100 000 000 000 000
Number of write cycles at ambient temperature < 40 °C maximum	1 000 000
Data retention time at ambient temperature < 40 °C not less than	10 y
Property of memory	Block-by-block write protection of the user memory
Type of transponder chip used	TI Tag-it HFI
Mechanical data	
Material	PVC laminated plastic
Color	white
Mounting distance relating to metal surfaces recommended minimum	25 mm
Permitted ambient conditions	
Ambient temperature	
• during read/write access	-20 ... +60 °C
• outside the read/write area	-20 ... +60 °C
• during storage	-20 ... +60 °C
Protection class IP	IP67
Shock resistance	According to DIN EN 60721-3-7 Class 7 M3
Resistance to mechanical stress	Shock and vibration according to ISO 10373 / ISO 7810, torsion and twisting according to ISO 10373 / ISO 7816-3
Design, dimensions and weight	
Width	54 mm
Height	0.8 mm
Depth	85 mm
Net weight	5 g
Mounting type	Gluing, mounting bag (see accessories)
Product properties, functions, components general	
Product feature	
• printable	Yes
Printing process	Printable on both sides
Standards, specifications, approvals	
MTBF	228 y
Accessories	
Accessories	Fixing strap, holder, spacer

Selection and ordering data

	Article No.
MDS D200 transponder 256 bytes EEPROM Ordering quantity 250 units or a multiple thereof.	6GT2600-1AD00-0AX0
<i>Accessories</i>	
Fixing pocket For MDS D200, usable together with spacer 6GT2190-0AA00. Ordering quantity 50 units or a multiple thereof.	6GT2190-0AB00
	
Spacer For fixing pocket (6GT2190-0AB00), thickness 20 mm The purpose of the spacer is to maintain the recommended distance to the metal when installing the transponder. Ordering quantity 50 units or a multiple thereof.	6GT2190-0AA00
	
Holder For MDS D200. Ordering quantity 50 units or a multiple thereof.	6GT2390-0AA00
	

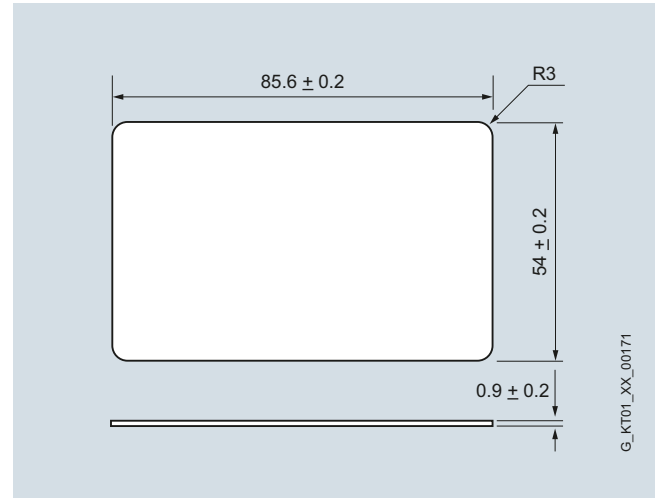
Dimensional drawings

MDS D200 transponder

RFID systems for the HF range

Transponder (ISO mode)

MDS D400

Overview



The MDS D400 is a passive, maintenance-free transponder based on the ISO standard 15693 with FRAM technology.

The MDS D400 transponder can be used for the RFID system MOBY D as well as for SIMATIC RF300 (ISO mode) and SIMATIC RF200.



Application

ISO transponder, suitable for the identification of transport units in production-related logistics.

Technical specifications

Article number	6GT2600-4AD00
Product type designation	MDS D400 transponder
Suitability for operation	RF200, RF300, MOBY D
Wireless frequencies	
Operating frequency Rated value	13.56 MHz
Electrical data	
Range maximum	650 mm; range is reader dependent: observe http://support.automation.siemens.com/WW/view/en/67384964
Protocol with radio transmission	ISO 15693
Transfer rate with radio transmission maximum	26.5 kbit/s
Product feature multitag-capable	Yes
Product component Backup battery	No
Memory	
Type of memory	FRAM
Storage capacity of the user memory	2 000 byte
Type of memory organization	UID (fixed code) 8 bytes, user memory 2 000 bytes, configuration memory 40 bytes
Number of read cycles at ambient temperature < 40 °C maximum	1 000 000 000 000
Number of write cycles at ambient temperature < 40 °C maximum	1 000 000 000 000
Data retention time at ambient temperature < 40 °C not less than	10 y
Property of memory	Block-by-block write protection of the user memory
Type of transponder chip used	Fujitsu MB89R118
Mechanical data	
Material	PVC laminated plastic
Color	white
Mounting distance relating to metal surfaces recommended minimum	20 mm
Permitted ambient conditions	
Ambient temperature	
• during read/write access	-20 ... +60 °C
• outside the read/write area	-20 ... +60 °C
• during storage	-20 ... +60 °C
Protection class IP	IP67
Shock resistance	According to DIN EN 60721-3-7 Class 7 M3
Resistance to mechanical stress	acc. to ISO 10373/ ISO 7816-1
Design, dimensions and weight	
Width	54 mm
Height	0.8 mm
Depth	85.6 mm
Net weight	5 g
Mounting type	gluing, mounting bag (see accessories)
Product properties, functions, components general	
Product feature	
• printable	Yes
Printing process	Printable on both sides
Standards, specifications, approvals	
MTBF	228 y
Accessories	
Accessories	Fixing strap, holder, spacer

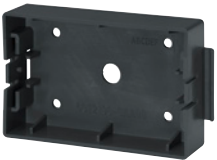
Selection and ordering data

	Article No.
MDS D400 transponder 2 000 bytes EEPROM. <i>Accessories</i>	6GT2600-4AD00
Fixing pocket For MDS D400, usable together with spacer 6GT2190-0AA00. Ordering quantity 50 units or a multiple thereof.	6GT2190-0AB00
	
Spacer For fixing pocket (6GT2190-0AB00), thickness 20 mm The purpose of the spacer is to maintain the recommended distance to the metal when installing the transponder. Ordering quantity 50 units or a multiple thereof.	6GT2190-0AA00
	
Holder For MDS D400. Ordering quantity 50 units or a multiple thereof.	6GT2390-0AA00
	

Dimensional drawings

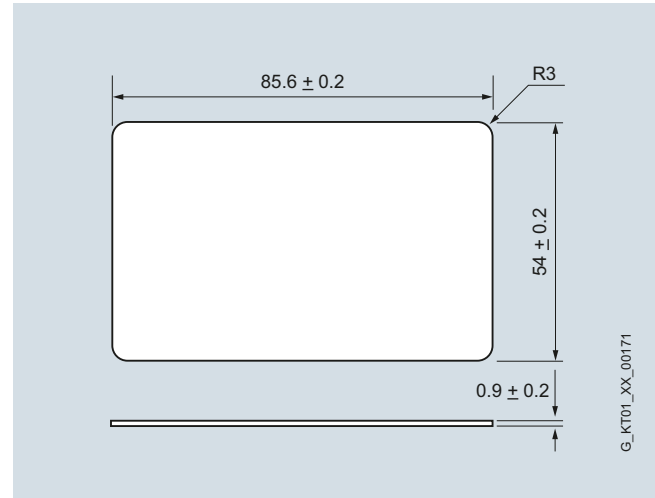

MDS D400 transponder

RFID systems for the HF range

Transponder (ISO mode)

MDS D421

Overview



The MDS D421 is a passive (maintenance-free) transponder based on ISO 15693, with FRAM technology.

Note

This transponder is used exclusively with the following readers/antennas:

- RF210R
- RF250R with ANT 8, ANT 12 or ANT 18
- RF350R with ANT 12 or ANT 18
- RF350M with external antenna

Application

The MDS D421 is designed for tool coding according to DIN 69873.

It can be used wherever small transponders and exact positioning are required, for example, for tool identification or on workpiece holders.

Technical specifications

Article number	6GT2600-4AE00
Product type designation	MDS D421 transponder
Suitability for operation	RF200, RF300
Wireless frequencies	
Operating frequency Rated value	13.56 MHz
Electrical data	
Range maximum	8 mm; range is reader dependent: observe http://support.automation.siemens.com/WW/view/en/67384964
Protocol with radio transmission	ISO 15693
Transfer rate with radio transmission maximum	26.5 kbit/s
Product feature multitag-capable	Yes
Product component Backup battery	No
Memory	
Type of memory	FRAM
Storage capacity of the user memory	2 000 byte
Type of memory organization	UID (fixed code) 8 bytes, user memory 2 000 bytes, configuration memory 40 bytes
Number of read cycles at ambient temperature < 40 °C maximum	1 000 000 000 000
Number of write cycles at ambient temperature < 40 °C maximum	1 000 000 000 000
Data retention time at ambient temperature < 40 °C not less than	10 y
Property of memory	Block-by-block write protection of the user memory
Type of transponder chip used	Fujitsu MB89R118
Mechanical data	
Material	Epoxy resin
Color	black
Mounting distance relating to metal surfaces recommended minimum	0 mm
Permitted ambient conditions	
Ambient temperature	
• during read/write access	-25 ... +85 °C
• outside the read/write area	-40 ... +100 °C
• during storage	-40 ... +100 °C
Protection class IP	IP67 / IPx9K
Shock resistance	According to DIN EN 60721-3-7 Class 7 M3
Shock acceleration	1 000 m/s ²
Vibrational acceleration	200 m/s ²
Design, dimensions and weight	
Height	4.5 mm
Diameter	10 mm
Net weight	1 g
Mounting type	gluing
Product properties, functions, components general	
Product feature	
• silicon-free	Yes
• printable	No

Selection and ordering data

	Article No.
MDS D421 transponder 2 000 bytes FRAM Ordering quantity 10 units or a multiple thereof.	6GT2600-4AE00

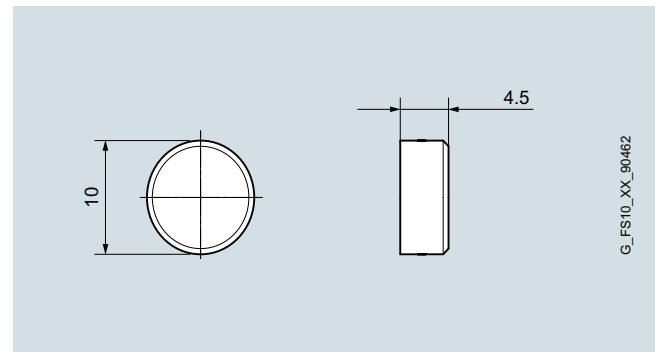
Dimensional drawings

MDS D421 transponder

RFID systems for the HF range

Transponder (ISO mode)

MDS D521

Overview



The MDS D521 is a passive (maintenance-free) transponder based on ISO 15693, with FRAM technology.

The transponder can only be operated with the SIMATIC RF200 RFID system.

Application

The MDS D521 is designed for tool coding according to DIN 69873.

It can be used wherever small transponders and exact positioning are required, for example, for tool identification or on workpiece holders.

Technical specifications

Article number	6GT2600-5AE00
Product type designation	MDS D521 transponder
Suitability for operation	RF200
Wireless frequencies	
Operating frequency Rated value	13.56 MHz
Electrical data	
Range maximum	5 mm; range is reader dependent: observe http://support.automation.siemens.com/WW/view/en/67384964
Protocol with radio transmission	ISO 15693
Transfer rate with radio transmission maximum	26.5 kbit/s
Product feature multitag-capable	Yes
Product component Backup battery	No
Memory	
Type of memory	FRAM
Storage capacity of the user memory	8 192 byte
Type of memory organization	UID (fixed code) 8 bytes, user memory 8 192 bytes, configuration memory 40 bytes
Number of read cycles at ambient temperature < 40 °C maximum	1 000 000 000 000
Number of write cycles at ambient temperature < 40 °C maximum	1 000 000 000 000
Data retention time at ambient temperature < 40 °C not less than	10 y
Property of memory	Block-by-block write protection of the user memory
Type of transponder chip used	Fujitsu MB89R112
Mechanical data	
Material	Epoxy resin
Color	black
Mounting distance relating to metal surfaces recommended minimum	0 mm
Permitted ambient conditions	
Ambient temperature	
• during read/write access	-25 ... +85 °C
• outside the read/write area	-40 ... +100 °C
• during storage	-40 ... +100 °C
Protection class IP	IP67 / IPx9K
Shock resistance	According to DIN EN 60721-3-7 Class 7 M3
Shock acceleration	1 000 m/s ²
Vibrational acceleration	200 m/s ²
Design, dimensions and weight	
Height	4.5 mm
Diameter	10 mm
Net weight	1 g
Mounting type	gluing
Product properties, functions, components general	
Product feature	
• silicon-free	Yes
• printable	No

Selection and ordering data

	Article No.
MDS D521 transponder 8 192 byte FRAM Ordering quantity 10 units or a multiple thereof.	6GT2600-5AE00

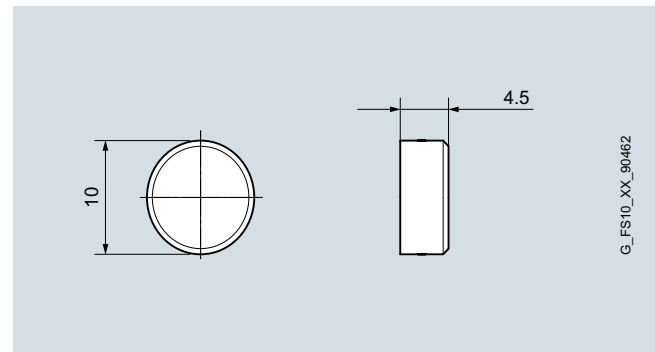
Dimensional drawings

MDS D521 transponder

RFID systems for the HF range

Transponder (ISO mode)

MDS D422

Overview



The MDS D422 is a passive (maintenance-free) transponder based on ISO 15693, with FRAM technology.

The transponder can be operated with the SIMATIC RF200 and SIMATIC RF300 (ISO mode) RFID systems.

When operated with a mobile reader, the RF350M must be used with an external antenna.

Application

Identification of metallic workpiece holders, workpieces or containers.

Technical specifications

Article number	6GT2600-4AF00
Product type designation	MDS D422 transponder
Suitability for operation	RF200, RF300
Wireless frequencies	
Operating frequency Rated value	13.56 MHz
Electrical data	
Range maximum	19 mm; range is reader dependent: observe http://support.automation.siemens.com/WW/view/en/67384964
Protocol with radio transmission	ISO 15693
Transfer rate with radio transmission maximum	26.5 kbit/s
Product feature multitag-capable	Yes
Product component Backup battery	No
Memory	
Type of memory	FRAM
Storage capacity of the user memory	2 000 byte
Type of memory organization	UID (fixed code) 8 bytes, user memory 2 000 bytes, configuration memory 40 bytes
Number of read cycles at ambient temperature < 40 °C maximum	1 000 000 000 000
Number of write cycles at ambient temperature < 40 °C maximum	1 000 000 000 000
Data retention time at ambient temperature < 40 °C not less than	10 y
Property of memory	Block-by-block write protection of the user memory
Type of transponder chip used	Fujitsu MB89R118
Mechanical data	
Material	PA6.6 GF / brass, nickel-plated
Color	black / silver
Tightening torque of the screw for securing the equipment maximum	1 Nm
Mounting distance relating to metal surfaces recommended minimum	0 mm
Permitted ambient conditions	
Ambient temperature	
• during read/write access	-25 ... +85 °C
• outside the read/write area	-40 ... +100 °C
• during storage	-40 ... +100 °C
Protection class IP	IP68
Shock resistance	According to DIN EN 60721-3-7 Class 7 M3
Shock acceleration	500 m/s ²
Vibrational acceleration	200 m/s ²
Design, dimensions and weight	
Height	6 mm
Diameter	20 mm
Net weight	13 g
Mounting type	gluing, screwing
Product properties, functions, components general	
Product feature	
• silicon-free	Yes
• printable	No
Standards, specifications, approvals	
MTBF	228 y

Selection and ordering data

	Article No.
MDS D422 transponder 2 000 bytes FRAM One installation tool is included in each packing unit. Ordering quantity 5 units or a multiple thereof.	6GT2600-4AF00

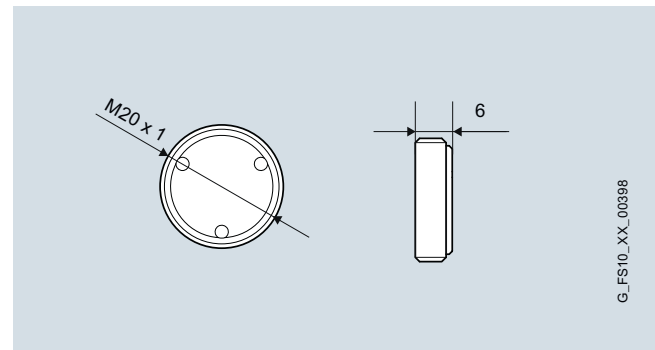
Dimensional drawings

MDS D422 transponder

RFID systems for the HF range

Transponder (ISO mode)

MDS D522

Overview



The MDS D522 is a passive (maintenance-free) transponder based on ISO 15693, with FRAM technology.

The transponder can only be operated with the RFID system SIMATIC RF200.

Operation with a mobile reader is currently only possible with RF210M.

Application

Identification of metallic workpiece holders, workpieces or containers.

Technical specifications

Article number	6GT2600-5AF00	6GT2600-5AF00-0AX0
Product type designation	MDS D522 transponder For gluing or screwing	MDS D522 transponder For clipping
Suitability for operation	RF200	RF200
Wireless frequencies		
Operating frequency Rated value	13.56 MHz	13.56 MHz
Electrical data		
Range maximum	35 mm; range is reader dependent: observe	35 mm; range is reader dependent: observe
http://support.automation.siemens.com/WW/view/en/67384964		
Protocol with radio transmission	ISO 15693	ISO 15693
Transfer rate with radio transmission maximum	26.5 kbit/s	26.5 kbit/s
Product feature multitag-capable	Yes	Yes
Product component Backup battery	No	No
Memory		
Type of memory	FRAM	FRAM
Storage capacity of the user memory	8 192 byte	8 192 byte
Type of memory organization	UID (fixed code) 8 bytes, user memory 8 192 bytes, configuration memory 40 bytes	UID (fixed code) 8 bytes, user memory 8 192 bytes, configuration memory 48 bytes
Number of read cycles at ambient temperature < 40 °C maximum	1 000 000 000 000	1 000 000 000 000
Number of write cycles at ambient temperature < 40 °C maximum	1 000 000 000 000	1 000 000 000 000
Data retention time at ambient temperature < 40 °C not less than	10 y	10 y
Property of memory	Block-by-block write protection of the user memory	Block-by-block write protection of the user memory
Type of transponder chip used	Fujitsu MB89R112	Fujitsu MB89R112
Mechanical data		
Material	PA6.6 GF / brass, nickel-plated	PA6.6 GF
Color	black / silver	black
Tightening torque of the screw for securing the equipment maximum	1 Nm	-
Mounting distance relating to metal surfaces recommended minimum	0 mm	0 mm
Permitted ambient conditions		
Ambient temperature		
• during read/write access	-25 ... +85 °C	-25 ... +85 °C
• outside the read/write area	-40 ... +100 °C	-40 ... +100 °C
• during storage	-40 ... +100 °C	-40 ... +100 °C
Protection class IP	IP68	IP68
Shock resistance	According to DIN EN 60721-3-7 Class 7 M3	According to DIN EN 60721-3-7 Class 7 M3
Shock acceleration	500 m/s ²	500 m/s ²
Vibrational acceleration	200 m/s ²	200 m/s ²

Article number	6GT2600-5AF00	6GT2600-5AF00-0AX0
Product type designation	MDS D522 transponder For gluing or screwing	MDS D522 transponder For clipping
Suitability for operation	RF200	RF200
Design, dimensions and weight		
Height	6 mm	5.2 mm
Diameter	20 mm	18 mm
Net weight	13 g	1.2 g
Mounting type	gluing, screwing	Clip into the pre-milled contour according to the operating instructions
Product properties, functions, components general		
Product feature		
• silicon-free	Yes	Yes
• printable	No	No
Standards, specifications, approvals		
MTBF	228 y	200 y

Dimensional drawings

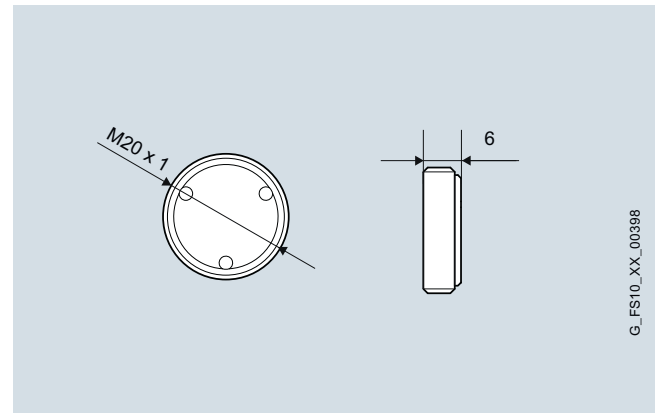

MDS D522 transponder for gluing or screwing (6GT2600-5AF00)

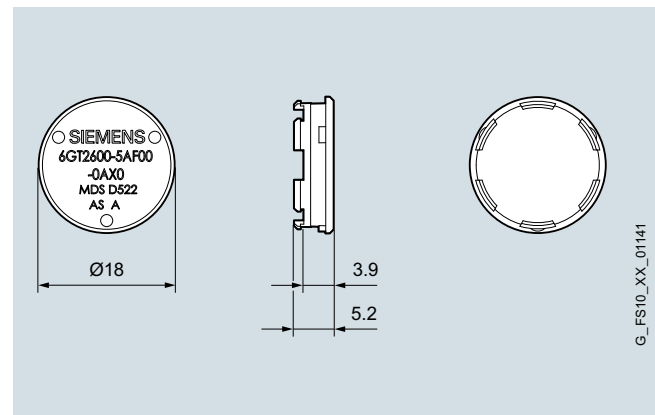

MDS D522 transponder for clip attachment (6GT2600-5AF00-0AX0)

Selection and ordering data

	Article No.
MDS D522 transponder	
For SIMATIC RF200	
8 192 byte FRAM	
Ordering quantity 10 units or a multiple thereof.	
• For attachment with glue or screws onto metal.	6GT2600-5AF00
One screw-in aid is included in each packing unit.	
• for clipping onto metal	6GT2600-5AF00-0AX0

RFID systems for the HF range

Transponder (ISO mode)

MDS D423

Overview



The MDS D423 is a passive (maintenance-free) transponder based on ISO 15693, with FRAM technology.

The transponder can be operated with the SIMATIC RF200 and SIMATIC RF300 (ISO mode) RFID systems.

Application

The particularly compact transponder of small design can be flush-mounted in metal and is thus suitable for identifying metallic workpiece holders, workpieces or containers.

As a result of its high IP68 / IPx9K degree of protection, it is suitable for use in particularly harsh environments such as the passage through washers.

Technical specifications

Article number	6GT2600-4AA00
Product type designation	MDS D423 transponder
Suitability for operation	RF200, RF300
Wireless frequencies	
Operating frequency Rated value	13.56 MHz
Electrical data	
Range maximum	80 mm; range is reader dependent: observe http://support.automation.siemens.com/WW/view/en/67384964
Protocol with radio transmission	ISO 15693
Transfer rate with radio transmission maximum	26.5 kbit/s
Product feature multitag-capable	Yes
Product component Backup battery	No
Memory	
Type of memory	FRAM
Storage capacity of the user memory	2 000 byte
Type of memory organization	UID (fixed code) 8 bytes, user memory 2 000 bytes, configuration memory 40 bytes
Number of read cycles at ambient temperature < 40 °C maximum	1 000 000 000 000
Number of write cycles at ambient temperature < 40 °C maximum	1 000 000 000 000
Data retention time at ambient temperature < 40 °C not less than	10 y
Property of memory	Block-by-block write protection of the user memory
Type of transponder chip used	Fujitsu MB89R118
Mechanical data	
Material	PPS
Color	black
Tightening torque of the screw for securing the equipment maximum	1 Nm
Mounting distance relating to metal surfaces recommended minimum	0 mm
Permitted ambient conditions	
Ambient temperature	
• during read/write access	-25 ... +85 °C
• outside the read/write area	-40 ... +100 °C
• during storage	-40 ... +100 °C
Protection class IP	IP68 / IPx9K
Shock resistance	According to DIN EN 60721-3-7 Class 7 M3
Shock acceleration	500 m/s ²
Vibrational acceleration	200 m/s ²
Design, dimensions and weight	
Height	8 mm
Diameter	30 mm
Net weight	15 g
Mounting type	M4 countersunk screw
Product properties, functions, components general	
Product feature	
• silicon-free	Yes
• printable	No
Standards, specifications, approvals	
MTBF	228 y
Accessories	
Accessories	mounting hood

Selection and ordering data

	Article No.
MDS D423 transponder 2 000 bytes FRAM Ordering quantity 10 units or a multiple thereof.	6GT2600-4AA00
Accessories	
Mounting cover Length = 50 mm, height = 10 mm, temperature range up to 100 °C, ordering quantity 10 units or a multiple thereof.	6GT2690-0AE00

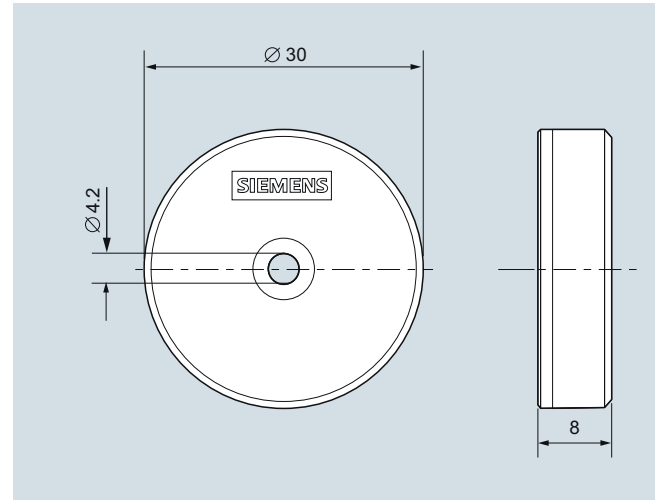
Dimensional drawings

MDS D423 transponder

RFID systems for the HF range

Transponder (ISO mode)

MDS D124

Overview

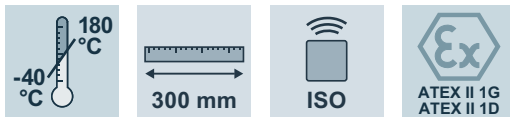
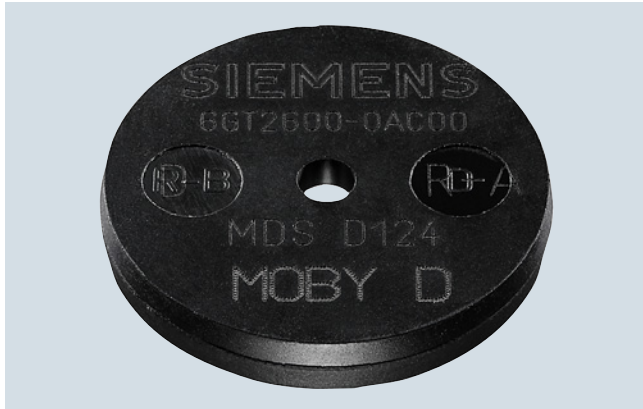

The MDS D124 is a mobile, passive, maintenance-free transponder based on the ISO 15693 standard.

The MDS D124 can be used for the RFID system MOBY D as well as for SIMATIC RF200 and SIMATIC RF300 (ISO mode).

Application

This transponder can even be used problem-free under extreme environmental conditions (e.g. when subjected to temperatures up to +180 °C).

Technical specifications

Article number	6GT2600-0AC10
Product type designation	MDS D124 transponder
Suitability for operation	RF200, RF300, MOBY D
Wireless frequencies	
Operating frequency Rated value	13.56 MHz
Electrical data	
Range maximum	300 mm; range is reader dependent: observe
http://support.automation.siemens.com/WWW/view/en/67384964	
Protocol with radio transmission	ISO 15693
Transfer rate with radio transmission maximum	26.5 kbit/s
Product feature multitag-capable	Yes
Product component Backup battery	No

Article number	6GT2600-0AC10
Product type designation	MDS D124 transponder
Suitability for operation	RF200, RF300, MOBY D
Memory	
Type of memory	EEPROM
Storage capacity of the user memory	112 byte
Type of memory organization	UID (fixed code) 8 bytes, user memory 112 bytes, configuration memory 8 bytes
Number of read cycles at ambient temperature < 40 °C maximum	100 000 000 000 000
Number of write cycles at ambient temperature < 40 °C maximum	1 000 000
Data retention time at ambient temperature < 40 °C not less than	10 y
Property of memory	Block-by-block write protection of the user memory
Type of transponder chip used	NXP I-Code SLI
Mechanical data	
Material	PPS
Color	black
Tightening torque of the screw for securing the equipment maximum	1 Nm
Mounting distance relating to metal surfaces recommended minimum	15 mm
Permitted ambient conditions	
Ambient temperature	
• during read/write access	-25 ... +125 °C
• outside the read/write area	-40 ... +180 °C
• during storage	-40 ... +125 °C
Ambient condition for operation	Operating temperature permanent up to 100 °C, at 180 °C: up to 5 000 hours or 3 000 temperature cycles
Protection class IP	IP68 / IPx9K
Shock resistance	According to DIN EN 60721-3-7 Class 7 M3
Shock acceleration	1 000 m/s ²
Vibrational acceleration	200 m/s ²
Design, dimensions and weight	
Height	4 mm
Diameter	27 mm
Net weight	5 g
Mounting type	M3 screw, gluing
Product properties, functions, components general	
Product feature	
• silicon-free	Yes
• printable	No
Standards, specifications, approvals	
Certificate of suitability	Ex: II 1 G Ex ia IIC T3/T6 Ga / II 1 D Ex ia IIIC T80°C/T180°C
MTBF	171 y
Accessories	
Accessories	Mounting support and spacer

Selection and ordering data

	Article No.
MDS D124 transponder 112 bytes EEPROM Ordering quantity 20 units or a multiple thereof.	6GT2600-0AC10
Accessories	
Mounting support and spacer For MDS D124, MDS D324, MDS D424, MDS D524 and RF320T. Necessary for mounting onto metal surfaces. Diameter = 35 mm, height = 15 mm Ordering quantity 20 units or a multiple thereof.	6GT2690-0AK00



Dimensional drawings

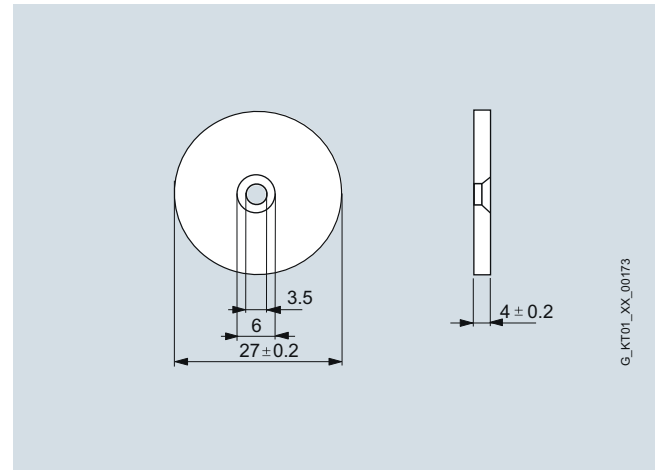

MDS D124 transponder

RFID systems for the HF range

Transponder (ISO mode)

MDS D324

Overview

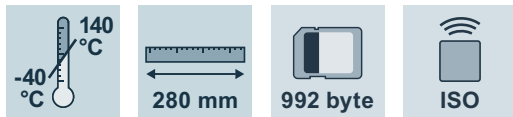
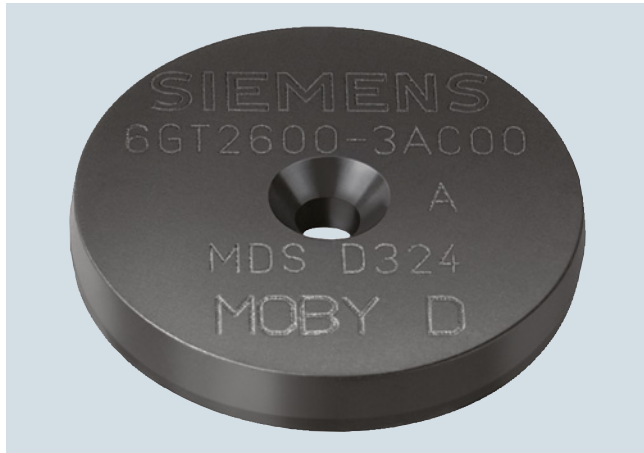

The MDS D324 is a passive (maintenance-free) transponder based on ISO 15693.

The MDS D324 can be used for the RFID system MOBY D as well as for SIMATIC RF200 and SIMATIC RF300 (ISO mode).

Application

The MDS D324 was developed for applications in production and distribution logistics as well as product identification.

For the user, the usable application memory amounts to 992 byte.

This transponder can also be easily used in harsh environments under extreme environmental conditions (e.g. with higher thermal stress).

Technical specifications

Article number	6GT2600-3AC00
Product type designation	MDS D324 transponder
Suitability for operation	RF200, RF300, MOBY D
Wireless frequencies	
Operating frequency Rated value	13.56 MHz
Electrical data	
Range maximum	280 mm; range is reader dependent: observe http://support.automation.siemens.com/WW/view/en/67384964
Protocol with radio transmission	ISO 15693
Transfer rate with radio transmission maximum	26.5 kbit/s
Product feature multitag-capable	Yes
Product component Backup battery	No
Memory	
Type of memory	EEPROM
Storage capacity of the user memory	992 byte
Type of memory organization	UID (fixed code) 8 bytes, user memory 992 bytes, configuration memory 24 bytes 100 000 000 000 000
Number of read cycles at ambient temperature < 40 °C maximum	1 000 000
Number of write cycles at ambient temperature < 40 °C maximum	10 y
Data retention time at ambient temperature < 40 °C not less than	10 y
Property of memory	Block-by-block write protection of the user memory
Type of transponder chip used	Infineon My-D SRF 55V10P
Mechanical data	
Material	Epoxy resin
Color	black
Tightening torque of the screw for securing the equipment maximum	1 Nm
Mounting distance relating to metal surfaces recommended minimum	15 mm
Permitted ambient conditions	
Ambient temperature	
• during read/write access	-25 ... +125 °C
• outside the read/write area	-40 ... +140 °C
• during storage	-40 ... +140 °C
Protection class IP	IP67
Shock resistance	According to DIN EN 60721-3-7 Class 7 M3
Shock acceleration	1 000 m/s ²
Vibrational acceleration	200 m/s ²
Design, dimensions and weight	
Height	4 mm
Diameter	27 mm
Net weight	5 g
Mounting type	M3 screw, gluing
Product properties, functions, components general	
Product feature	
• silicon-free	Yes
• printable	No
Standards, specifications, approvals	
MTBF	171 y
Accessories	
Accessories	Mounting support and spacer

Selection and ordering data

	Article No.
MDS D324 transponder 992 bytes EEPROM Ordering quantity 20 units or a multiple thereof.	6GT2600-3AC00
<i>Accessories</i>	
Mounting support and spacer For MDS D124, MDS D324, MDS D424, MDS D524 and RF320T. Necessary for mounting onto metal surfaces. Diameter = 35 mm, height = 15 mm Ordering quantity 20 units or a multiple thereof.	6GT2690-0AK00



Dimensional drawings

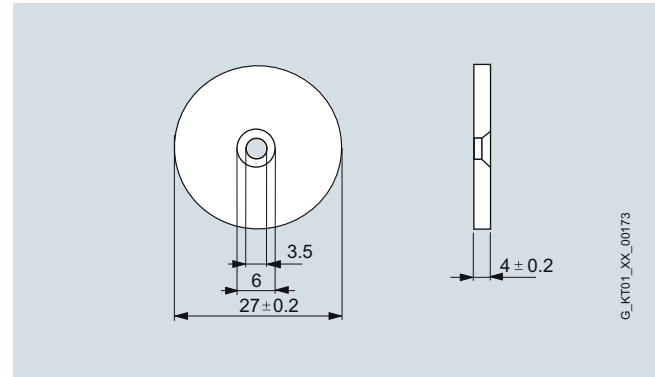

MDS D324 transponder

RFID systems for the HF range

Transponder (ISO mode)

MDS D424

Overview

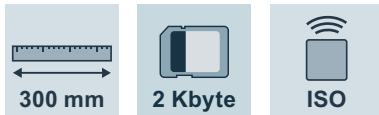

The MDS D424 is a passive (maintenance-free) transponder based on ISO 15693, with FRAM technology.

The MDS D424 can be used for the RFID system MOBY D as well as for SIMATIC RF200 and SIMATIC RF300 (ISO mode).

Application

The MDS D424 was developed for applications in production and distribution logistics as well as for use in assembly and production lines.

Technical specifications

Article number	6GT2600-4AC00
Product type designation	MDS D424 transponder
Suitability for operation	RF200, RF300, MOBY D
Wireless frequencies	
Operating frequency Rated value	13.56 MHz
Electrical data	
Range maximum	300 mm; range is reader dependent: observe http://support.automation.siemens.com/WW/view/en/67384964
Protocol with radio transmission	ISO 15693
Transfer rate with radio transmission maximum	26.5 kbit/s
Product feature multitag-capable	Yes
Product component Backup battery	No
Memory	
Type of memory	FRAM
Storage capacity of the user memory	2 000 byte
Type of memory organization	UID (fixed code) 8 bytes, user memory 2 000 bytes, configuration memory 40 bytes
Number of read cycles at ambient temperature < 40 °C maximum	1 000 000 000 000
Number of write cycles at ambient temperature < 40 °C maximum	1 000 000 000 000
Data retention time at ambient temperature < 40 °C not less than	10 y
Property of memory	Block-by-block write protection of the user memory
Type of transponder chip used	Fujitsu MB89R118
Mechanical data	
Material	Epoxy resin
Color	black
Tightening torque of the screw for securing the equipment maximum	1 Nm
Mounting distance relating to metal surfaces recommended minimum	15 mm
Permitted ambient conditions	
Ambient temperature	
• during read/write access	-25 ... +85 °C
• outside the read/write area	-40 ... +100 °C
• during storage	-40 ... +100 °C
Protection class IP	IP67 / IPx9K
Shock resistance	According to DIN EN 60721-3-7 Class 7 M3
Shock acceleration	1 000 m/s ²
Vibrational acceleration	200 m/s ²
Design, dimensions and weight	
Height	4 mm
Diameter	27 mm
Net weight	5 g
Mounting type	M3 screw, gluing
Product properties, functions, components general	
Product feature	
• silicon-free	Yes
• printable	No
Standards, specifications, approvals	
MTBF	171 y
Accessories	
Accessories	Mounting support and spacer

Selection and ordering data

	Article No.
MDS D424 transponder 2 000 bytes FRAM Ordering quantity 20 units or a multiple thereof.	6GT2600-4AC00
<i>Accessories</i>	
Mounting support and spacer For MDS D124, MDS D324, MDS D424, MDS D524 and RF320T. Necessary for mounting onto metal surfaces. Diameter = 35 mm, height = 15 mm Ordering quantity 20 units or a multiple thereof.	6GT2690-0AK00



Dimensional drawings

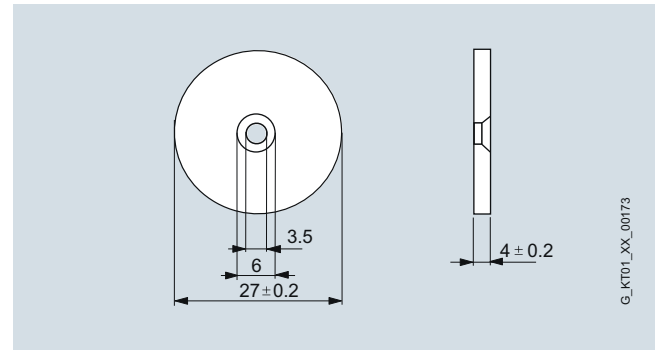

MDS D424 transponder

RFID systems for the HF range

Transponder (ISO mode)

MDS D524

Overview



The MDS D524 is a passive (maintenance-free) transponder based on ISO 15693, with FRAM technology.

The transponder can only be operated with the SIMATIC RF200 RFID system.

Application

The transponder is designed for use in production and distribution logistics as well as in assembly and production lines.

Technical specifications

Article number	6GT2600-5AC00
Product type designation	MDS D524 transponder
Suitability for operation	RF200
Wireless frequencies	
Operating frequency Rated value	13.56 MHz
Electrical data	
Range maximum	300 mm; range is reader dependent: observe http://support.automation.siemens.com/WW/view/en/67384964
Protocol with radio transmission	ISO 15693
Transfer rate with radio transmission maximum	26.5 kbit/s
Product feature multitag-capable	Yes
Product component Backup battery	No
Memory	
Type of memory	FRAM
Storage capacity of the user memory	8 192 byte
Type of memory organization	UID (fixed code) 8 bytes, user memory 8 192 bytes, configuration memory 40 bytes
Number of read cycles at ambient temperature < 40 °C maximum	1 000 000 000 000
Number of write cycles at ambient temperature < 40 °C maximum	1 000 000 000 000
Data retention time at ambient temperature < 40 °C not less than	10 y
Property of memory	Block-by-block write protection of the user memory
Type of transponder chip used	Fujitsu MB89R112
Mechanical data	
Material	Epoxy resin
Color	black
Tightening torque of the screw for securing the equipment maximum	1 Nm
Mounting distance relating to metal surfaces recommended minimum	15 mm
Permitted ambient conditions	
Ambient temperature	
• during read/write access	-25 ... +85 °C
• outside the read/write area	-40 ... +100 °C
• during storage	-40 ... +100 °C
Protection class IP	IP67 / IPx9K
Shock resistance	According to DIN EN 60721-3-7 Class 7 M3
Shock acceleration	1 000 m/s ²
Vibrational acceleration	200 m/s ²
Design, dimensions and weight	
Height	4 mm
Diameter	27 mm
Net weight	5 g
Mounting type	M3 screw, gluing
Product properties, functions, components general	
Product feature	
• silicon-free	Yes
• printable	No
Standards, specifications, approvals	
MTBF	171 y
Accessories	
Accessories	Mounting support and spacer

Selection and ordering data

	Article No.
MDS D524 transponder 8 192 byte FRAM Ordering quantity 20 units or a multiple thereof.	6GT2600-5AC00
<i>Accessories</i>	
Mounting support and spacer For MDS D124, MDS D324, MDS D424, MDS D524 and RF320T. Necessary for mounting onto metal surfaces. Diameter = 35 mm, height = 15 mm Ordering quantity 20 units or a multiple thereof.	6GT2690-0AK00



Dimensional drawings

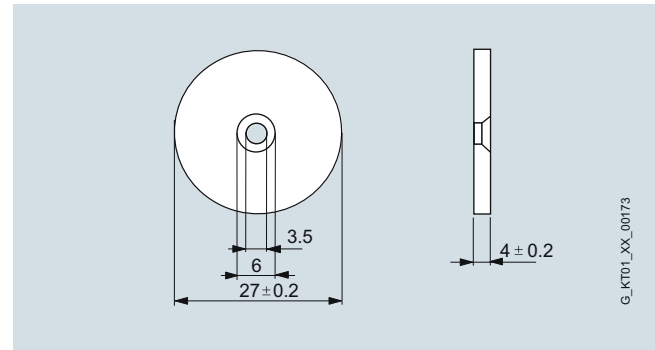

MDS D524 transponder

RFID systems for the HF range

Transponder (ISO mode)

MDS D425

Overview

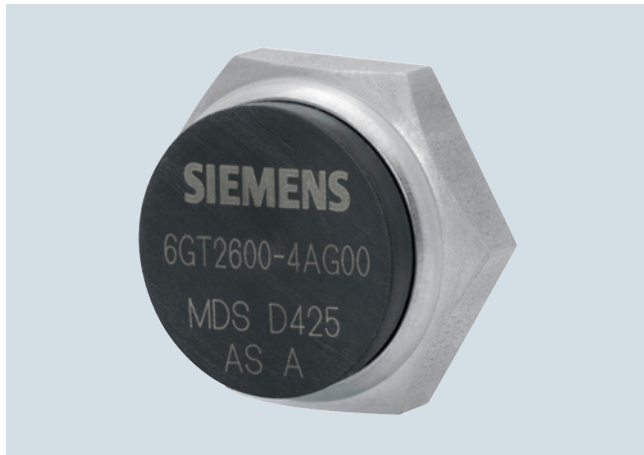

The MDS D425 is a passive (maintenance-free) transponder based on ISO 15693, with FRAM technology.

The MDS D425 can be operated with the SIMATIC RF200 and SIMATIC RF300 (ISO mode) RFID systems.

Application

The MDS D425 is a compact and rugged ISO transponder suitable for screw mounting.

It has been designed for applications in assembly and production lines in the powertrain sector.

Technical specifications

Article number	6GT2600-4AG00
Product type designation	MDS D425 transponder
Suitability for operation	RF200, RF300
Wireless frequencies	
Operating frequency Rated value	13.56 MHz
Electrical data	
Range maximum	45 mm; range is reader dependent: observe http://support.automation.siemens.com/WW/view/en/67384964
Protocol with radio transmission	ISO 15693
Transfer rate with radio transmission maximum	26.5 kbit/s
Product feature multitag-capable	Yes
Product component Backup battery	No
Memory	
Type of memory	FRAM
Storage capacity of the user memory	2 000 byte
Type of memory organization	UID (fixed code) 8 bytes, user memory 2 000 bytes, configuration memory 40 bytes
Number of read cycles at ambient temperature < 40 °C maximum	1 000 000 000 000
Number of write cycles at ambient temperature < 40 °C maximum	1 000 000 000 000
Data retention time at ambient temperature < 40 °C not less than	10 y
Property of memory	Block-by-block write protection of the user memory
Type of transponder chip used	Fujitsu MB89R118
Mechanical data	
Material	PA6.6 GF / stainless steel
Color	black / silver
Tightening torque of the screw for securing the equipment maximum	6 Nm
Mounting distance relating to metal surfaces recommended minimum	0 mm
Permitted ambient conditions	
Ambient temperature	
• during read/write access	-25 ... +85 °C
• outside the read/write area	-40 ... +125 °C
• during storage	-40 ... +125 °C
Protection class IP	IP68 / IPx9K
Shock resistance	According to DIN EN 60721-3-7 Class 7 M3
Shock acceleration	500 m/s ²
Vibrational acceleration	200 m/s ²
Design, dimensions and weight	
Height	10 mm
Diameter	24 mm
Net weight	35 g
Mounting type	screwing (M6)
Product properties, functions, components general	
Product feature	
• silicon-free	Yes
• printable	No
Standards, specifications, approvals	
MTBF	228 y

Selection and ordering data

	Article No.
MDS D425 transponder 2 000 bytes FRAM Ordering quantity 5 units or a multiple thereof.	6GT2600-4AG00

Dimensional drawings

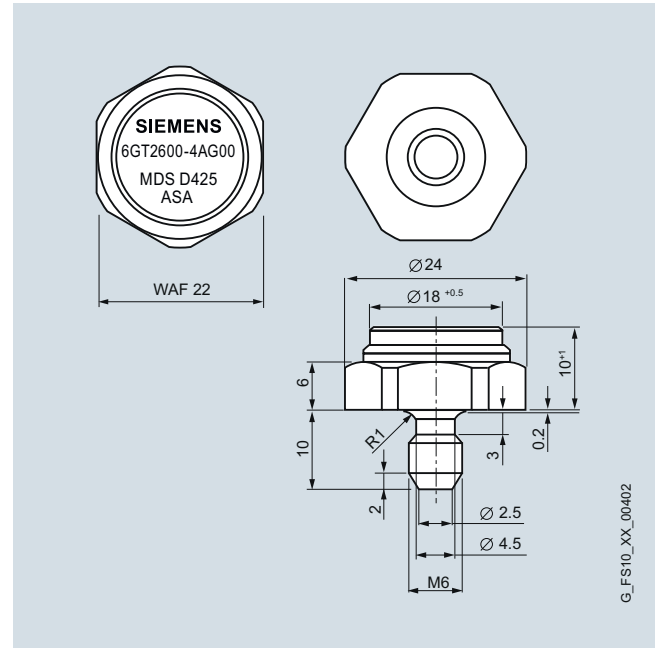

MDS D425 transponder

RFID systems for the HF range

Transponder (ISO mode)

MDS D525

Overview

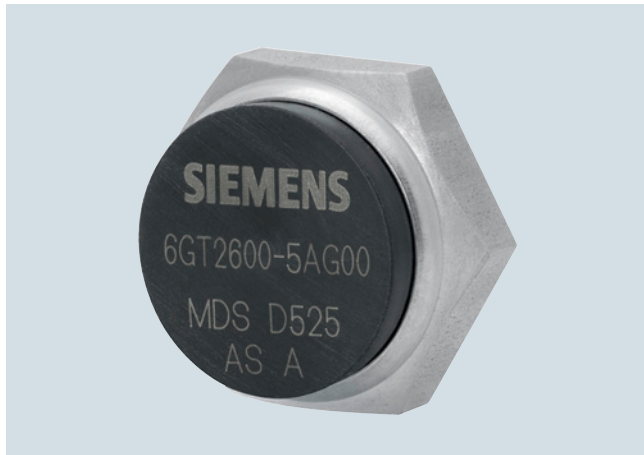

The MDS D525 is a passive (maintenance-free) transponder based on ISO 15693, with FRAM technology.

The transponder can only be operated with the SIMATIC RF200 RFID system.

Application

The MDS D525 is a compact and rugged ISO transponder suitable for screw mounting.

It is designed for use in assembly and production lines as well as in the powertrain sector.

Technical specifications

Article number	6GT2600-5AG00
Product type designation	MDS D525 transponder
Suitability for operation	RF200
Wireless frequencies	
Operating frequency Rated value	13.56 MHz
Electrical data	
Range maximum	50 mm; range is reader dependent: observe http://support.automation.siemens.com/WW/view/en/67384964
Protocol with radio transmission	ISO 15693
Transfer rate with radio transmission maximum	26.5 kbit/s
Product feature multitag-capable	Yes
Product component Backup battery	No
Memory	
Type of memory	FRAM
Storage capacity of the user memory	8 192 byte
Type of memory organization	UID (fixed code) 8 bytes, user memory 8 192 bytes, configuration memory 40 bytes
Number of read cycles at ambient temperature < 40 °C maximum	1 000 000 000 000
Number of write cycles at ambient temperature < 40 °C maximum	1 000 000 000 000
Data retention time at ambient temperature < 40 °C not less than	10 y
Property of memory	Block-by-block write protection of the user memory
Type of transponder chip used	Fujitsu MB89R112
Mechanical data	
Material	PA6.6 GF / stainless steel
Color	black / silver
Tightening torque of the screw for securing the equipment maximum	6 Nm
Mounting distance relating to metal surfaces recommended minimum	0 mm
Permitted ambient conditions	
Ambient temperature	
• during read/write access	-25 ... +85 °C
• outside the read/write area	-40 ... +125 °C
• during storage	-40 ... +125 °C
Protection class IP	IP68 / IPx9K
Shock resistance	According to DIN EN 60721-3-7 Class 7 M3
Shock acceleration	500 m/s ²
Vibrational acceleration	200 m/s ²
Design, dimensions and weight	
Height	10 mm
Diameter	24 mm
Net weight	35 g
Mounting type	screwing (M6)
Product properties, functions, components general	
Product feature	
• silicon-free	Yes
• printable	No
Standards, specifications, approvals	
MTBF	228 y

Selection and ordering data

	Article No.
MDS D525 transponder 8 192 byte FRAM Order quantity 5 units or a multiple thereof.	6GT2600-5AG00

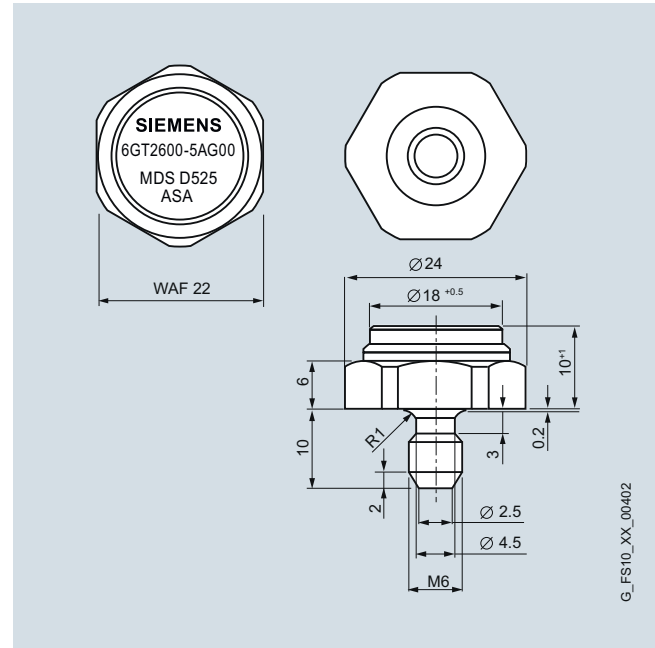
Dimensional drawings

MDS D525 transponder

RFID systems for the HF range

Transponder (ISO mode)

MDS D126

Overview



The MDS D126 is a passive (maintenance-free) transponder based on ISO 15693.

The MDS D126 can be used for the RFID system MOBY D as well as for SIMATIC RF200 and SIMATIC RF300 (ISO mode).

Application

The MDS D126 is a compact and rugged ISO transponder suitable for the identification of transport units in production-related logistics.

The transponder can also be used in harsh environments.

Technical specifications

Article number	6GT2600-0AE00
Product type designation	MDS D126 transponder
Suitability for operation	RF200, RF300, MOBY D
Wireless frequencies	
Operating frequency Rated value	13.56 MHz
Electrical data	
Range maximum	500 mm; range is reader dependent: observe http://support.automation.siemens.com/WW/view/en/67384964
Protocol with radio transmission	ISO 15693
Transfer rate with radio transmission maximum	26.5 kbit/s
Product feature multitag-capable	Yes
Product component Backup battery	No
Memory	
Type of memory	EEPROM
Storage capacity of the user memory	112 byte
Type of memory organization	UID (fixed code) 8 bytes, user memory 112 bytes, configuration memory 8 bytes
Number of read cycles at ambient temperature < 40 °C maximum	100 000 000 000 000
Number of write cycles at ambient temperature < 40 °C maximum	1 000 000
Data retention time at ambient temperature < 40 °C not less than	10 y
Property of memory	Block-by-block write protection of the user memory
Type of transponder chip used	NXP I-Code SLI
Mechanical data	
Material	PA6.6 GF
Color	black
Tightening torque of the screw for securing the equipment maximum	1 Nm
Mounting distance relating to metal surfaces recommended minimum	25 mm
Permitted ambient conditions	
Ambient temperature	
• during read/write access	-25 ... +85 °C
• outside the read/write area	-40 ... +100 °C
• during storage	-40 ... +100 °C
Protection class IP	IP68
Shock resistance	According to DIN EN 60721-3-7 Class 7 M3
Shock acceleration	500 m/s ²
Vibrational acceleration	200 m/s ²
Design, dimensions and weight	
Height	3.6 mm
Diameter	50 mm
Net weight	13 g
Mounting type	M4 screw
Product properties, functions, components general	
Product feature	
• printable	No
Standards, specifications, approvals	
MTBF	171 y
Accessories	
Accessories	Mounting support and spacer

Selection and ordering data

	Article No.
MDS D126 transponder 112 bytes EEPROM Ordering quantity 250 units or a multiple thereof.	6GT2600-0AE00
<i>Accessories</i>	
Mounting support and spacer For MDS D126, necessary for mounting onto metal surfaces. Diameter = 60 mm, height = 30 mm. Ordering quantity 50 units or a multiple thereof.	6GT2690-0AL00

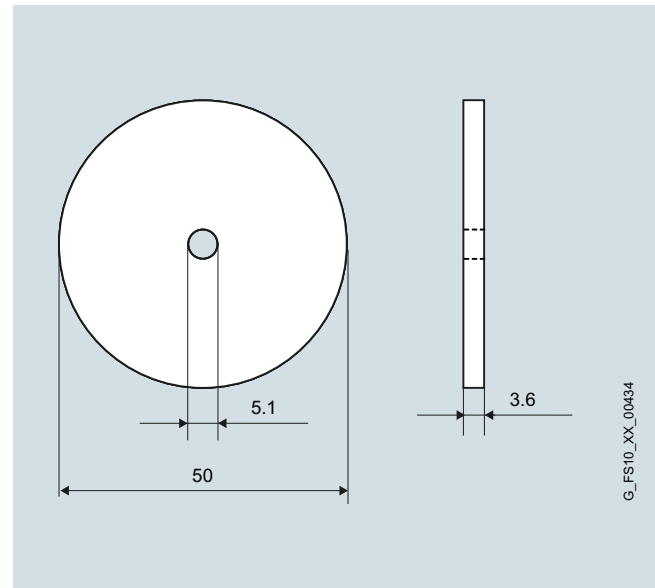
Dimensional drawings

MDS D126 transponder

RFID systems for the HF range

Transponder (ISO mode)

MDS D426

Overview



The MDS D426 is a passive (maintenance-free) transponder based on ISO 15693, with FRAM technology.

The MDS D426 can be used for the RFID system MOBY D as well as for SIMATIC RF200 and SIMATIC RF300 (ISO mode).

Application

The MDS D426 is a compact and rugged ISO transponder suitable for the identification of transport units in production-related logistics.

The transponder can also be used in harsh environments.

Technical specifications

Article number	6GT2600-4AH00
Product type designation	MDS D426 transponder
Suitability for operation	RF200, RF300, MOBY D
Wireless frequencies	
Operating frequency Rated value	13.56 MHz
Electrical data	
Range maximum	400 mm; range is reader dependent: observe http://support.automation.siemens.com/WW/view/en/67384964
Protocol with radio transmission	ISO 15693
Transfer rate with radio transmission maximum	26.5 kbit/s
Product feature multitag-capable	Yes
Product component Backup battery	No
Memory	
Type of memory	FRAM
Storage capacity of the user memory	2 000 byte
Type of memory organization	UID (fixed code) 8 bytes, user memory 2 000 bytes, configuration memory 40 bytes
Number of read cycles at ambient temperature < 40 °C maximum	1 000 000 000 000
Number of write cycles at ambient temperature < 40 °C maximum	1 000 000 000 000
Data retention time at ambient temperature < 40 °C not less than	10 y
Property of memory	Block-by-block write protection of the user memory
Type of transponder chip used	Fujitsu MB89R118
Mechanical data	
Material	PA6.6 GF
Color	black
Tightening torque of the screw for securing the equipment maximum	1 Nm
Mounting distance relating to metal surfaces recommended minimum	25 mm
Permitted ambient conditions	
Ambient temperature	
• during read/write access	-25 ... +85 °C
• outside the read/write area	-40 ... +100 °C
• during storage	-40 ... +100 °C
Protection class IP	IP68
Shock resistance	According to DIN EN 60721-3-7 Class 7 M3
Shock acceleration	500 m/s ²
Vibrational acceleration	200 m/s ²
Design, dimensions and weight	
Height	3.6 mm
Diameter	50 mm
Net weight	13 g
Mounting type	M4 screw
Product properties, functions, components general	
Product feature	
• printable	No
Standards, specifications, approvals	
MTBF	228 y
Accessories	
Accessories	Mounting support and spacer

Selection and ordering data

	Article No.
MDS D426 transponder 2 000 bytes FRAM Ordering quantity 50 units or a multiple thereof.	6GT2600-4AH00
Accessories	
Mounting support and spacer For MDS D426, necessary for mounting onto metal surfaces. Diameter = 60 mm, height = 30 mm Ordering quantity 50 units or a multiple thereof.	6GT2690-0AL00

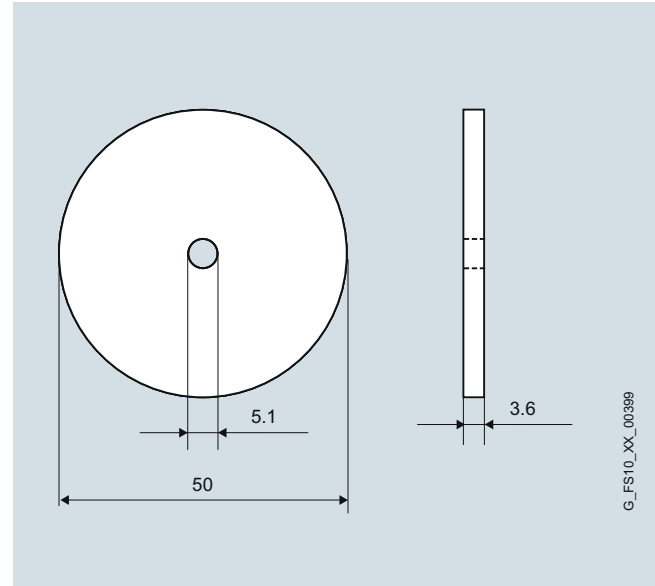
Dimensional drawings

MDS D426 transponder

RFID systems for the HF range

Transponder (ISO mode)

MDS D526

Overview



The MDS D526 is a passive (maintenance-free) transponder based on ISO 15693, with FRAM technology.

The transponder can only be operated with the SIMATIC RF200 RFID system.

Application

The MDS D526 is a compact and rugged ISO transponder which can also be used under harsh environmental conditions.

It is designed for the identification of transport units in production-related logistics.

Technical specifications

Article number	6GT2600-5AH00
Product type designation	MDS D526 transponder
Suitability for operation	RF200
Wireless frequencies	
Operating frequency Rated value	13.56 MHz
Electrical data	
Range maximum	400 mm; range is reader dependent: observe http://support.automation.siemens.com/WW/view/en/67384964
Protocol with radio transmission	ISO 15693
Transfer rate with radio transmission maximum	26.5 kbit/s
Product feature multitag-capable	Yes
Product component Backup battery	No
Memory	
Type of memory	FRAM
Storage capacity of the user memory	8 192 byte
Type of memory organization	UID (fixed code) 8 bytes, user memory 8 192 bytes, configuration memory 40 bytes
Number of read cycles at ambient temperature < 40 °C maximum	1 000 000 000 000
Number of write cycles at ambient temperature < 40 °C maximum	1 000 000 000 000
Data retention time at ambient temperature < 40 °C not less than	10 y
Property of memory	Block-by-block write protection of the user memory
Type of transponder chip used	Fujitsu MB89R112
Mechanical data	
Material	PA6.6 GF
Color	black
Tightening torque of the screw for securing the equipment maximum	1 Nm
Mounting distance relating to metal surfaces recommended minimum	25 mm
Permitted ambient conditions	
Ambient temperature	
• during read/write access	-25 ... +85 °C
• outside the read/write area	-40 ... +100 °C
• during storage	-40 ... +100 °C
Protection class IP	IP68
Shock resistance	According to DIN EN 60721-3-7 Class 7 M3
Shock acceleration	500 m/s ²
Vibrational acceleration	200 m/s ²
Design, dimensions and weight	
Height	3.6 mm
Diameter	50 mm
Net weight	13 g
Mounting type	M4 screw
Product properties, functions, components general	
Product feature	
• printable	No
Standards, specifications, approvals	
MTBF	228 y
Accessories	
Accessories	Mounting support and spacer

Selection and ordering data

	Article No.
MDS D526 transponder 8 192 byte FRAM Ordering quantity 50 units or a multiple thereof.	6GT2600-5AH00
<i>Accessories</i>	
Mounting support and spacer For MDS D526, necessary for mounting onto metal surfaces. Diameter = 60 mm, height = 30 mm Ordering quantity 50 units or a multiple thereof.	6GT2690-0AL00

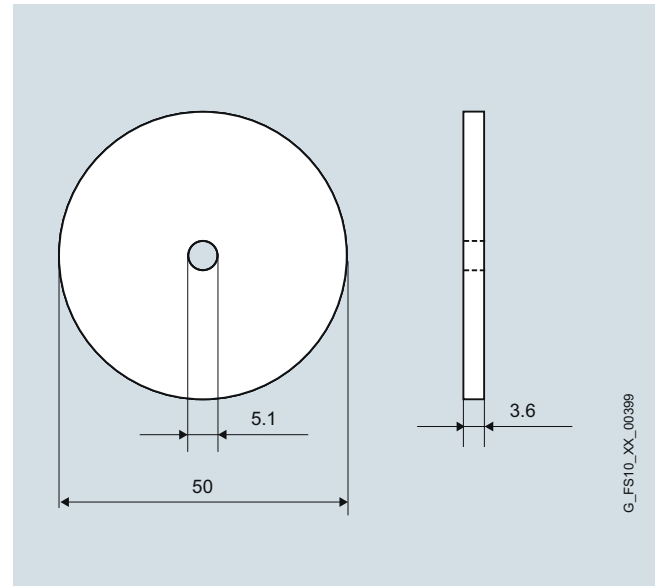
Dimensional drawings

MDS D526 transponder

RFID systems for the HF range

Transponder (ISO mode)

MDS D117

Overview

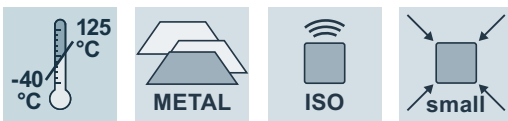
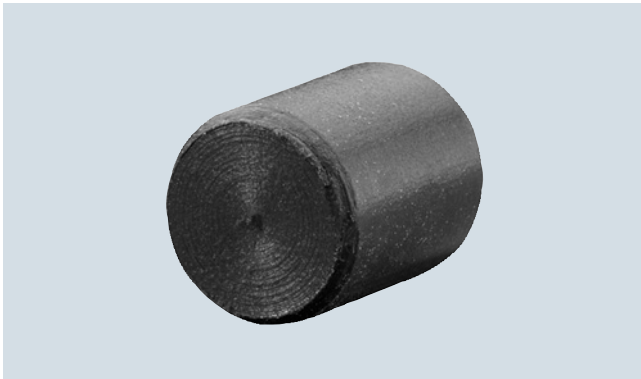

The MDS D117 is a passive, maintenance-free transponder based on ISO 15693. It is small and compact and can be mounted on metal using adhesive.

The mobile data memory can be operated with the SIMATIC RF300 (ISO mode) and SIMATIC RF200 RFID systems. When operated with the RF350M mobile handheld terminal, an external antenna must be used.

Application

For direct identification of small metallic workpieces and workpiece holders.



Size comparison of match to MDS D117

Technical specifications

Article number	6GT2600-0AG00
Product type designation	MDS D117 transponder
Suitability for operation	RF200, RF300
Wireless frequencies	
Operating frequency Rated value	13.56 MHz
Electrical data	
Range maximum	4 mm; range is reader dependent: observe http://support.automation.siemens.com/WW/view/en/67384964
Protocol with radio transmission	ISO 15693
Transfer rate with radio transmission maximum	26.5 kbit/s
Product feature multitag-capable	Yes
Product component Backup battery	No
Memory	
Type of memory	EEPROM
Storage capacity of the user memory	112 byte
Type of memory organization	UID (fixed code) 8 bytes, user memory 112 bytes, configuration memory 8 bytes
Number of read cycles at ambient temperature < 40 °C maximum	100 000 000 000 000
Number of write cycles at ambient temperature < 40 °C maximum	1 000 000
Data retention time at ambient temperature < 40 °C not less than	10 y
Property of memory	Block-by-block write protection of the user memory
Type of transponder chip used	NXP I-Code SLI
Mechanical data	
Material	PPS
Color	black
Mounting distance relating to metal surfaces recommended minimum	0 mm
Permitted ambient conditions	
Ambient temperature	
• during read/write access	-25 ... +85 °C
• outside the read/write area	-40 ... +125 °C
• during storage	-40 ... +125 °C
Protection class IP	IP68 / IPx9K
Shock resistance	According to DIN EN 60721-3-7 Class 7 M3
Shock acceleration	1 000 m/s ²
Vibrational acceleration	200 m/s ²
Design, dimensions and weight	
Height	5.2 mm
Diameter	4 mm
Net weight	1 g
Mounting type	gluing
Product properties, functions, components general	
Product feature	
• printable	No
Standards, specifications, approvals	
MTBF	228 y

Selection and ordering data

	Article No.
MDS D117 transponder 112 bytes EEPROM Ordering quantity 10 units or a multiple thereof.	6GT2600-0AG00

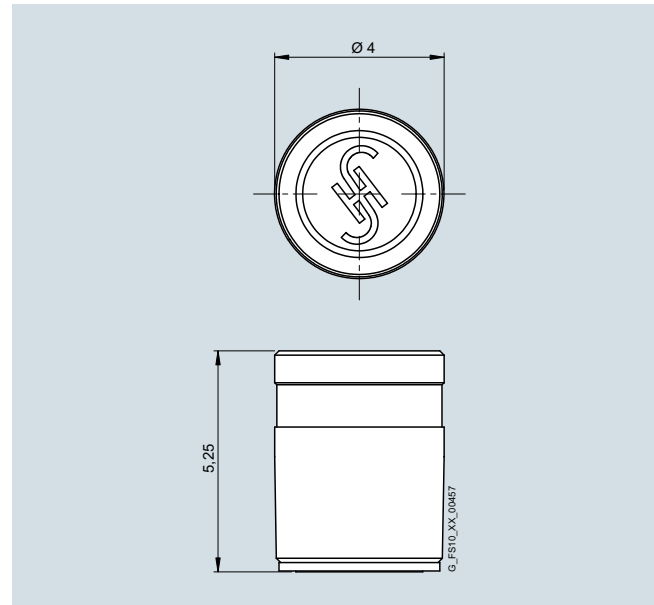
Dimensional drawings

MDS D117 transponder

RFID systems for the HF range

Transponder (ISO mode)

MDS D127

Overview



The MDS D127 is a passive, maintenance-free transponder based on ISO 15693. It is small and compact and can be screwed into metal.

The mobile data memory can only be operated with the SIMATIC RF300 (ISO mode) and SIMATIC RF200 RFID systems. When operated with the RF350M mobile handheld terminal, an external antenna must be used.

Application

For direct identification of small metallic workpieces, workpiece holders, or containers.

Technical specifications

Article number	6GT2600-0AF00
Product type designation	MDS D127 transponder
Suitability for operation	RF200, RF300
Wireless frequencies	
Operating frequency Rated value	13.56 MHz
Electrical data	
Range maximum	5 mm; range is reader dependent: observe http://support.automation.siemens.com/WW/view/en/67384964
Protocol with radio transmission	ISO 15693
Transfer rate with radio transmission maximum	26.5 kbit/s
Product feature multitag-capable	Yes
Product component Backup battery	No
Memory	
Type of memory	EEPROM
Storage capacity of the user memory	112 byte
Type of memory organization	UID (fixed code) 8 bytes, user memory 112 bytes, configuration memory 8 bytes
Number of read cycles at ambient temperature < 40 °C maximum	100 000 000 000 000
Number of write cycles at ambient temperature < 40 °C maximum	1 000 000
Data retention time at ambient temperature < 40 °C not less than	10 y
Property of memory	Block-by-block write protection of the user memory
Type of transponder chip used	NXP I-Code SLI
Mechanical data	
Material	PA6
Color	black
Mounting distance relating to metal surfaces recommended minimum	0 mm
Permitted ambient conditions	
Ambient temperature	
• during read/write access	-25 ... +100 °C
• outside the read/write area	-40 ... +125 °C
• during storage	-40 ... +125 °C
Protection class IP	IP68 / IPx9K
Shock resistance	According to DIN EN 60721-3-7 Class 7 M3
Shock acceleration	1 000 m/s ²
Vibrational acceleration	200 m/s ²
Design, dimensions and weight	
Height	5.8 mm
Diameter	6 mm
Net weight	1 g
Mounting type	gluing, screwing
Product properties, functions, components general	
Product feature	
• printable	No
Standards, specifications, approvals	
MTBF	228 y

Selection and ordering data

	Article No.
MDS 127 transponder 112 bytes EEPROM Ordering quantity 10 units or a multiple thereof.	6GT2600-0AF00

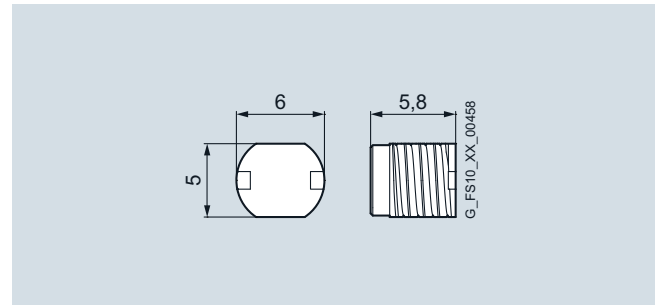
Dimensional drawings

MDS D127 transponder

RFID systems for the HF range

Transponder (ISO mode)

MDS D428

Overview



The MDS D428 is a passive (maintenance-free) transponder based on ISO 15693, with FRAM technology.

The MDS D428 can be used for the RFID system MOBY D as well as for SIMATIC RF200 and SIMATIC RF300 (ISO mode).

Application

The MDS D428 is a compact and rugged ISO transponder suitable for screw mounting.

It has been designed for applications in assembly and production lines in the powertrain sector.

Technical specifications

Article number	6GT2600-4AK00-0AX0
Product type designation	MDS D428 transponder
Suitability for operation	RF200, RF300, MOBY D
Wireless frequencies	
Operating frequency Rated value	13.56 MHz
Electrical data	
Range maximum	160 mm; range is reader dependent: observe http://support.automation.siemens.com/WW/view/en/67384964
Protocol with radio transmission	ISO 15693
Transfer rate with radio transmission maximum	26.5 kbit/s
Product feature multitag-capable	Yes
Product component Backup battery	No
Memory	
Type of memory	FRAM
Storage capacity of the user memory	2 000 byte
Type of memory organization	UID (fixed code) 8 bytes, user memory 2 000 bytes, configuration memory 40 bytes
Number of read cycles at ambient temperature < 40 °C maximum	1 000 000 000 000
Number of write cycles at ambient temperature < 40 °C maximum	1 000 000 000 000
Data retention time at ambient temperature < 40 °C not less than	10 y
Property of memory	Block-by-block write protection of the user memory
Type of transponder chip used	Fujitsu MB89R118
Mechanical data	
Material	PA6.6 GF / stainless steel
Color	black / silver
Tightening torque of the screw for securing the equipment maximum	6 Nm
Mounting distance relating to metal surfaces recommended minimum	0 mm
Permitted ambient conditions	
Ambient temperature	
• during read/write access	-25 ... +85 °C
• outside the read/write area	-40 ... +125 °C
• during storage	-40 ... +125 °C
Protection class IP	IP68 / IPx9K
Shock resistance	According to DIN EN 60721-3-7 Class 7 M3
Shock acceleration	500 m/s ²
Vibrational acceleration	200 m/s ²
Design, dimensions and weight	
Height	20 mm
Diameter	24 mm
Net weight	35 g
Mounting type	screwing (M8)
Product properties, functions, components general	
Product feature	
• silicon-free	Yes
• printable	No

Selection and ordering data
Article No.
MDS D428 transponder

2 000 bytes FRAM

With surface protection plate to prevent scratching of the screw-in surface.

Ordering quantity 5 units or a multiple thereof.

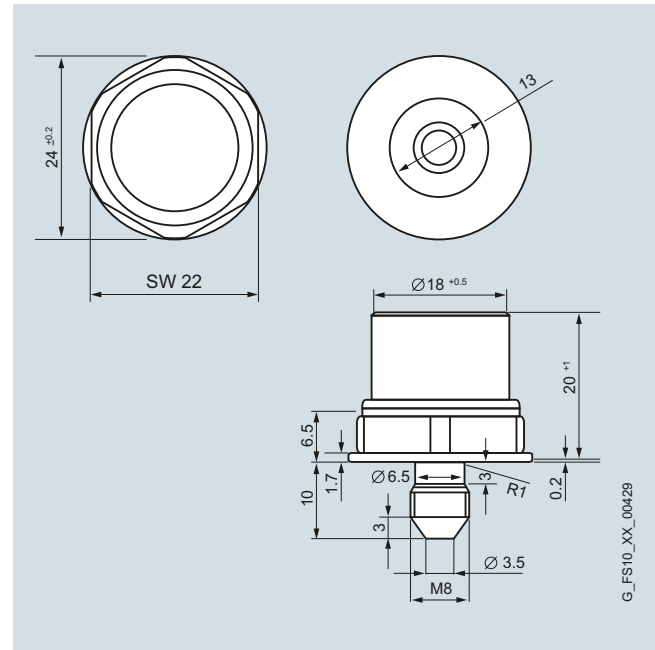
6GT2600-4AK00-0AX0
Dimensional drawings

MDS D428 transponder

RFID systems for the HF range

Transponder (ISO mode)

MDS D528

Overview



The MDS D528 is a passive (maintenance-free) transponder based on ISO 15693, with FRAM technology.

The transponder can only be operated with the SIMATIC RF200 RFID system.

Application

The MDS D528 is a compact and rugged ISO transponder suitable for screw mounting.

It is designed for use in assembly and production lines as well as in the powertrain sector.

Technical specifications

Article number	6GT2600-5AK00
Product type designation	MDS D528 transponder
Suitability for operation	RF200
Wireless frequencies	
Operating frequency Rated value	13.56 MHz
Electrical data	
Range maximum	160 mm; range is reader dependent: observe http://support.automation.siemens.com/WW/view/en/67384964
Protocol with radio transmission	ISO 15693
Transfer rate with radio transmission maximum	26.5 kbit/s
Product feature multitag-capable	Yes
Product component Backup battery	No
Memory	
Type of memory	FRAM
Storage capacity of the user memory	8 192 byte
Type of memory organization	UID (fixed code) 8 bytes, user memory 8 192 bytes, configuration memory 40 bytes
Number of read cycles at ambient temperature < 40 °C maximum	1 000 000 000 000
Number of write cycles at ambient temperature < 40 °C maximum	1 000 000 000 000
Data retention time at ambient temperature < 40 °C not less than	10 y
Property of memory	Block-by-block write protection of the user memory
Type of transponder chip used	Fujitsu MB89R112
Mechanical data	
Material	PA6.6 GF / stainless steel
Color	black / silver
Tightening torque of the screw for securing the equipment maximum	6 Nm
Mounting distance relating to metal surfaces recommended minimum	0 mm
Permitted ambient conditions	
Ambient temperature	
• during read/write access	-25 ... +85 °C
• outside the read/write area	-40 ... +125 °C
• during storage	-40 ... +125 °C
Protection class IP	IP68 / IPx9K
Shock resistance	According to DIN EN 60721-3-7 Class 7 M3
Shock acceleration	500 m/s ²
Vibrational acceleration	200 m/s ²
Design, dimensions and weight	
Height	20 mm
Diameter	18 mm
Net weight	35 g
Mounting type	screwing (M8)
Product properties, functions, components general	
Product feature	
• silicon-free	Yes
• printable	No

Selection and ordering data
Article No.
MDS D528 transponder

8 192 bytes of FRAM user memory
 With surface protection plate to prevent scratching of the screw-in surface.
 Ordering quantity 5 units or a multiple thereof.

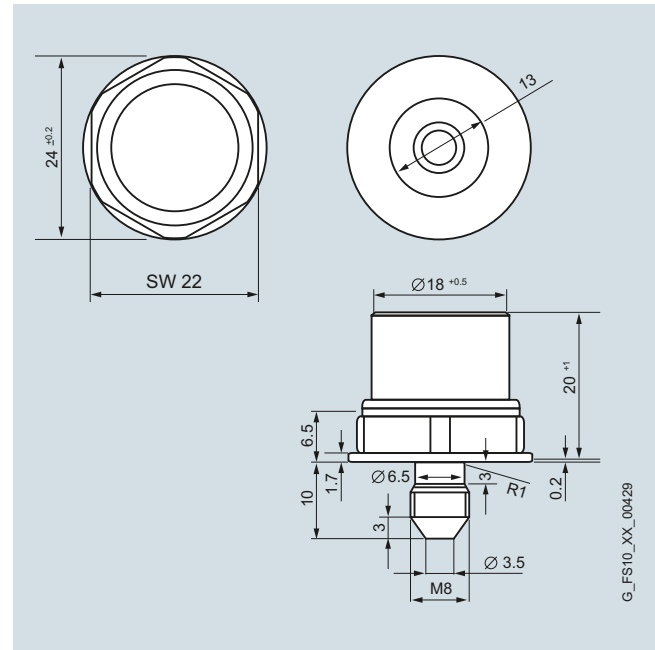
6GT2600-5AK00
Dimensional drawings

MDS D528 transponder

RFID systems for the HF range

Transponder (ISO mode)

MDS D139

Overview

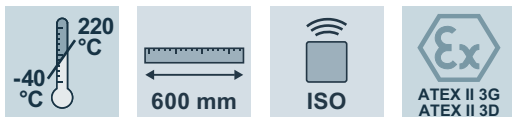

The MDS D139 is a passive (maintenance-free), heat-resistant transponder based on the ISO 15693 standard.

The MDS D139 can be used both for the MOBY D RFID system as well as for SIMATIC RF200 and SIMATIC RF300 (ISO mode).

Application



Applications in production logistics and in assembly lines subject to high temperatures (up to +200 °C, e.g. in a paint shop).

Technical specifications

Article number	6GT2600-0AA10
Product type designation	MDS D139 transponder
Suitability for operation	RF200, RF300, MOBY D
Wireless frequencies	
Operating frequency Rated value	13.56 MHz
Electrical data	
Range maximum	600 mm; range is reader dependent: observe
http://support.automation.siemens.com/WW/view/en/67384964	
Protocol with radio transmission	ISO 15693
Transfer rate with radio transmission maximum	26.5 kbit/s
Product feature multitag-capable	Yes
Product component Backup battery	No

Article number	6GT2600-0AA10
Product type designation	MDS D139 transponder
Suitability for operation	RF200, RF300, MOBY D
Memory	
Type of memory	EEPROM
Storage capacity of the user memory	112 byte
Type of memory organization	UID (fixed code) 8 bytes, user memory 112 bytes, configuration memory 8 bytes
Number of read cycles at ambient temperature < 40 °C maximum	100 000 000 000 000
Number of write cycles at ambient temperature < 40 °C maximum	1 000 000
Data retention time at ambient temperature < 40 °C not less than	10 y
Property of memory	Block-by-block write protection of the user memory
Type of transponder chip used	NXP I-Code SLI
Mechanical data	
Material	PPS
Color	black
Tightening torque of the screw for securing the equipment maximum	1.5 Nm
Mounting distance relating to metal surfaces recommended minimum	30 mm
Permitted ambient conditions	
Ambient temperature	
• during read/write access	-25 ... +100 °C
• outside the read/write area	-40 ... +220 °C
• during storage	-40 ... +100 °C
Ambient condition for operation	Operating temperature permanent up to 100 °C, at 220 °C: up to 2 000 hours or 1 500 temperature cycles, at 200 °C: up to 5 000 hours or 3 000 temperature cycles
Protection class IP	IP68 / IPx9K
Shock resistance	According to DIN EN 60721-3-7 Class 7 M3
Shock acceleration	500 m/s ²
Vibrational acceleration	200 m/s ²
Design, dimensions and weight	
Height	15 mm
Diameter	85 mm
Net weight	50 g
Mounting type	M5 screw
Product properties, functions, components general	
Product feature	
• silicon-free	Yes
• printable	No
Standards, specifications, approvals	
Certificate of suitability	Ex: II 3 G Ex nA II T2, II 3 D Ex tD A22 IP68 T 210°C
MTBF	228 y
Accessories	
Accessories	Spacer, quick-change holder

Selection and ordering data

	Article No.
MDS D139 transponder 112 bytes EEPROM Ordering quantity 10 units or a multiple thereof.	6GT2600-0AA10
Accessories	
Spacer Necessary for mounting onto metal surfaces. Ordering quantity 10 units or a multiple thereof.	6GT2690-0AA00
	
Quick change holder For MDS D139, stainless steel, diameter = 22 mm, height = 48 mm. Fixing with M8 nut. Ordering quantity 10 units or a multiple thereof.	6GT2690-0AH00
	
Quick change holder For MDS D139, stainless steel, diameter = 22 mm, height = 48 mm. With M10 female thread Ordering quantity 10 units or a multiple thereof.	6GT2690-0AH10
	

Dimensional drawings

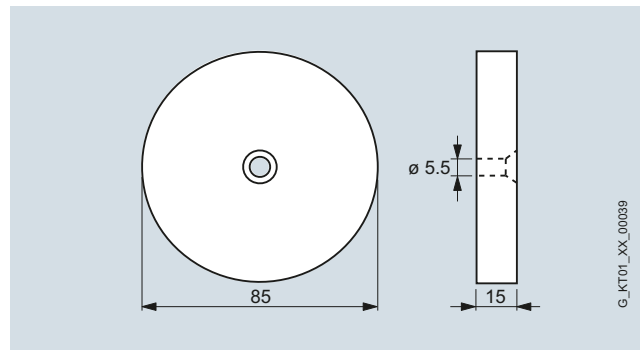

MDS D139 transponder

RFID systems for the HF range

Transponder (ISO mode)

MDS D339

Overview



The MDS D339 is a passive (maintenance-free), heat-resistant transponder based on ISO 15693.

The MDS D339 can be used for the RFID system MOBY D as well as for SIMATIC RF200 and SIMATIC RF300 (ISO mode).

Application



Applications in production logistics and in assembly lines subject to high temperatures (up to +220 °C, e.g. in a paint shop).

Technical specifications

Article number	6GT2600-3AA10
Product type designation	MDS D339 transponder
Suitability for operation	RF200, RF300, MOBY D
Wireless frequencies	
Operating frequency Rated value	13.56 MHz
Electrical data	
Range maximum	480 mm; range is reader dependent: observe
http://support.automation.siemens.com/WW/view/en/67384964	
Protocol with radio transmission	ISO 15693
Transfer rate with radio transmission maximum	26.5 kbit/s
Product feature multitag-capable	Yes
Product component Backup battery	No

Article number	6GT2600-3AA10
Product type designation	MDS D339 transponder
Suitability for operation	RF200, RF300, MOBY D
Memory	
Type of memory	EEPROM
Storage capacity of the user memory	992 byte
Type of memory organization	UID (fixed code) 8 bytes, user memory 992 bytes, configuration memory 24 bytes
Number of read cycles at ambient temperature < 40 °C maximum	100 000 000 000 000
Number of write cycles at ambient temperature < 40 °C maximum	1 000 000
Data retention time at ambient temperature < 40 °C not less than	10 y
Property of memory	Block-by-block write protection of the user memory
Type of transponder chip used	Infineon My-D SRF 55V10P
Mechanical data	
Material	PPS
Color	black
Tightening torque of the screw for securing the equipment maximum	1.5 Nm
Mounting distance relating to metal surfaces recommended minimum	30 mm
Permitted ambient conditions	
Ambient temperature	
• during read/write access	-25 ... +100 °C
• outside the read/write area	-40 ... +220 °C
• during storage	-40 ... +100 °C
Ambient condition for operation	Operating temperature permanent up to 100 °C, at 220 °C: up to 2 000 hours or 1 500 temperature cycles, at 200 °C: up to 5 000 hours or 3 000 temperature cycles
Protection class IP	IP68 / IPx9K
Shock resistance	According to DIN EN 60721-3-7 Class 7 M3
Shock acceleration	500 m/s ²
Vibrational acceleration	200 m/s ²
Design, dimensions and weight	
Height	15 mm
Diameter	85 mm
Net weight	50 g
Mounting type	M5 screw
Product properties, functions, components general	
Product feature	
• silicon-free	Yes
• printable	No
Standards, specifications, approvals	
Certificate of suitability	Ex: II 3 G Ex nA II T2, II 3 D Ex tD A22 IP68 T 210°C
MTBF	228 y
Accessories	
Accessories	Spacer, quick-change holder

Selection and ordering data

	Article No.
MDS D339 transponder 992 bytes EEPROM Ordering quantity 10 units or a multiple thereof.	6GT2600-3AA10
Accessories	
Spacer Necessary for mounting onto metal surfaces. Ordering quantity 10 units or a multiple thereof.	6GT2690-0AA00
	
Quick change holder For MDS D339, stainless steel, diameter = 22 mm, height = 48 mm. Fixing with M8 nut. Ordering quantity 10 units or a multiple thereof.	6GT2690-0AH00
	
Quick change holder For MDS D339, stainless steel, diameter = 22 mm, height = 48 mm. With M10 female thread Ordering quantity 10 units or a multiple thereof	6GT2690-0AH10
	

Dimensional drawings

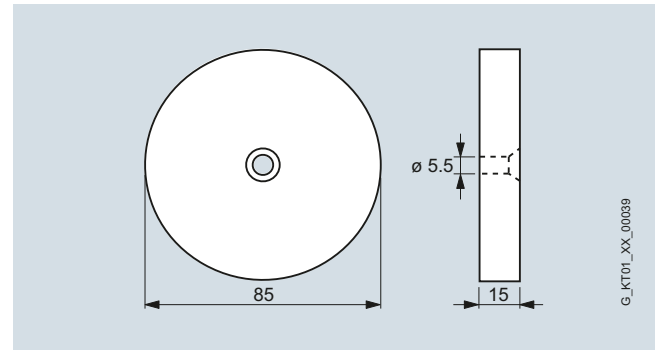

MDS D339 transponder

RFID systems for the HF range

Transponder (ISO mode)

MDS D160

Overview

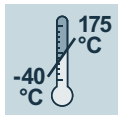
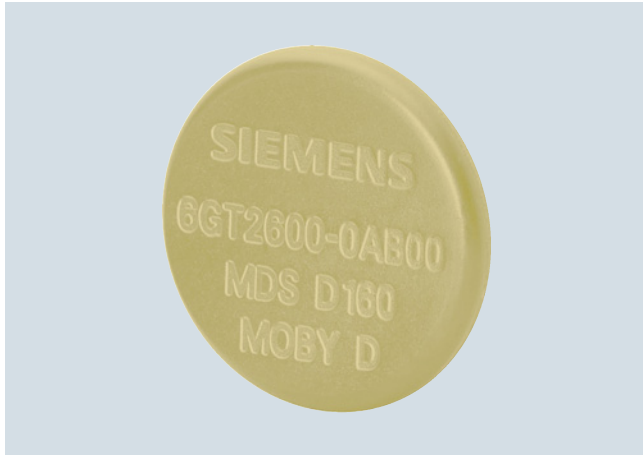

The MDS D160 is a passive, maintenance-free and rugged transponder based on the ISO 15693 standard.

The MDS D160 can be used for the RFID system MOBY D as well as for SIMATIC RF200 and SIMATIC RF300 (ISO mode).

Application

Typical applications are, for example:

- Rented work clothing
- Hotel laundry
- Surgical textiles
- Hospital clothing
- Dirt collection mats
- Clothing for nursing homes/hostels

Technical specifications

Article number	6GT2600-0AB10
Product type designation	MDS D160 transponder
Suitability for operation	RF200, RF300, MOBY D
Wireless frequencies	
Operating frequency Rated value	13.56 MHz
Electrical data	
Range maximum	180 mm; range is reader dependent: observe
http://support.automation.siemens.com/WWW/view/en/67384964	
Protocol with radio transmission	ISO 15693
Transfer rate with radio transmission maximum	26.5 kbit/s
Product feature multitag-capable	Yes
Product component Backup battery	No

Article number	6GT2600-0AB10
Product type designation	MDS D160 transponder
Suitability for operation	RF200, RF300, MOBY D
Memory	
Type of memory	EEPROM
Storage capacity of the user memory	112 byte
Type of memory organization	UID (fixed code) 8 bytes, user memory 112 bytes, configuration memory 8 bytes
Number of read cycles at ambient temperature < 40 °C maximum	100 000 000 000 000
Number of write cycles at ambient temperature < 40 °C maximum	1 000 000
Data retention time at ambient temperature < 40 °C not less than	10 y
Property of memory	Block-by-block write protection of the user memory
Type of transponder chip used	NXP I-Code SLI
Mechanical data	
Material	PPS
Color	beige
Mounting distance relating to metal surfaces recommended minimum	10 mm
Permitted ambient conditions	
Ambient temperature	
• during read/write access	-25 ... +85 °C
• outside the read/write area	-40 ... +175 °C
• during storage	-25 ... +100 °C
Ambient condition for operation	Operating temperature permanent up to 100 °C, up to 175 °C min. 100 washing cycles, one time up to 220 °C for 30 s
Protection class IP	IP68 / IPx9K
Shock resistance	According to DIN EN 60721-3-7 Class 7 M3
Shock acceleration	400 m/s ²
Vibrational acceleration	100 m/s ²
Design, dimensions and weight	
Height	3 mm
Diameter	16 mm
Net weight	1.2 g
Mounting type	patch, sewing, gluing
Product properties, functions, components general	
Product feature	
• printable	No
Standards, specifications, approvals	
MTBF	228 y
Accessories	
Accessories	Mounting support and spacer

Selection and ordering data

	Article No.
MDS D160 transponder 112 bytes EEPROM Ordering quantity 100 units or a multiple thereof.	6GT2600-0AB10
Accessories	
Spacer for MDS D160 For MDS D160, necessary for mounting onto metal surfaces. Diameter = 20 mm, height = 15 mm. Ordering quantity 50 units or a multiple thereof.	6GT2690-0AG00



Dimensional drawings

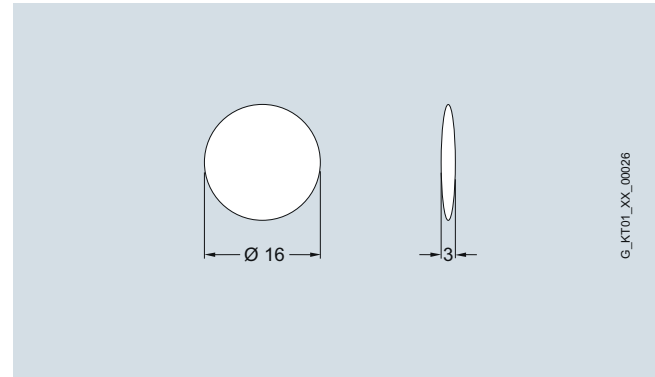

MDS D160 transponder

RFID systems for the HF range

Transponder (ISO mode)

MDS D460

Overview



The MDS D460 is a passive (maintenance-free) transponder based on ISO 15693, with FRAM technology.

The MDS D460 can be used for the RFID system MOBY D as well as for SIMATIC RF200 and SIMATIC RF300 (ISO mode).

Application

The MDS D460 has been designed for identification tasks in small assembly lines.

Technical specifications

Article number	6GT2600-4AB00
Product type designation	MDS D460 transponder
Suitability for operation	RF200, RF300, MOBY D
Wireless frequencies	
Operating frequency Rated value	13.56 MHz
Electrical data	
Range maximum	160 mm; range is reader dependent: observe http://support.automation.siemens.com/WW/view/en/67384964
Protocol with radio transmission	ISO 15693
Transfer rate with radio transmission maximum	26.5 kbit/s
Product feature multitag-capable	Yes
Product component Backup battery	No
Memory	
Type of memory	FRAM
Storage capacity of the user memory	2 000 byte
Type of memory organization	UID (fixed code) 8 bytes, user memory 2 000 bytes, configuration memory 40 bytes
Number of read cycles at ambient temperature < 40 °C maximum	1 000 000 000 000
Number of write cycles at ambient temperature < 40 °C maximum	1 000 000 000 000
Data retention time at ambient temperature < 40 °C not less than	10 y
Property of memory	Block-by-block write protection of the user memory
Type of transponder chip used	Fujitsu MB89R118
Mechanical data	
Material	Epoxy resin
Color	black
Mounting distance relating to metal surfaces recommended minimum	10 mm
Permitted ambient conditions	
Ambient temperature	
• during read/write access	-25 ... +85 °C
• outside the read/write area	-40 ... +100 °C
• during storage	-40 ... +100 °C
Protection class IP	IP67 / IPx9K
Shock resistance	According to DIN EN 60721-3-7 Class 7 M3
Shock acceleration	500 m/s ²
Vibrational acceleration	200 m/s ²
Design, dimensions and weight	
Height	3 mm
Diameter	16 mm
Net weight	3 g
Mounting type	patching, gluing
Product properties, functions, components general	
Product feature	
• printable	No
Standards, specifications, approvals	
MTBF	228 y
Accessories	
Accessories	Mounting support and spacer

Selection and ordering data

	Article No.
MDS D460 transponder 2 000 bytes FRAM Ordering quantity 50 units or a multiple thereof.	6GT2600-4AB00
Accessories	
Spacer For MDS D460, necessary for mounting onto metal surfaces. Diameter = 20 mm, height = 15 mm Ordering quantity 50 units or a multiple thereof.	6GT2690-0AG00

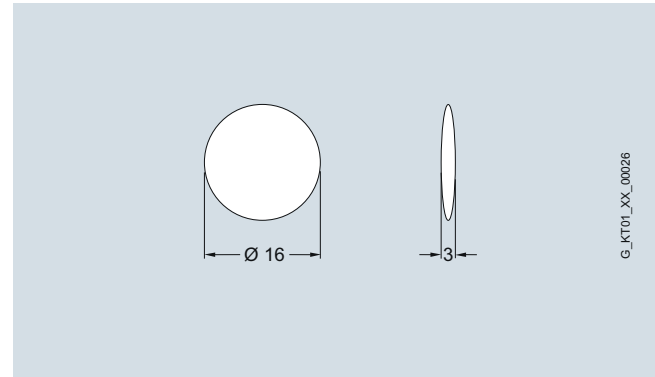
Dimensional drawings

MDS D460 transponder

RFID systems for the HF range

Transponder (RF300 mode)

Introduction

Overview

The following RF300 mode transponders can be used with the SIMATIC RF300 RFID system:

Transponder	Features	Page	Transponder	Features	Page
RF320T 	Small, compact, universal transponder. 20 byte EEPROM	2/61	RF370T 	Universal transponder with 32 KB or 64 KB memory, for mounting directly on metal, suitable for longer ranges.	2/71
RF330T 	Transponder, can be directly flush-mounted on metal. For directly identifying metallic workpieces or containers. 32 KB FRAM	2/63	RF380T 	Heat-resistant transponder, designed for skid identification in paint shops, for mounting directly on metal. Temperature range to +220 °C. 32 KB FRAM	2/73
RF340T 	Universal transponder, for mounting directly on metal, e.g. workpiece holders. 8 or 32 KB FRAM	2/65	<div style="border: 1px solid #0070C0; padding: 10px;">  Designed for Industry </div> <p>The comprehensive portfolio of SIMATIC RF300 transponders offers the right solution for every requirement in production:</p> <ul style="list-style-type: none"> • For high-performance applications. • Large memory up to 64 KB. • IP68 / IPx9K degree of protection. • Extremely rugged transponder for high temperature ranges up to 220 degrees with ATEX approval for use in paint shops. • Customized solutions for SmartLabels and transponders on request. 		
RF350T 	Universal transponder, for mounting directly on metal, suitable for longer ranges. 32 KB FRAM	2/67			
RF360T 	Universal transponder in credit card format. For mounting onto metal with spacer. 8 or 32 KB FRAM	2/69	<div style="border: 1px solid #0070C0; padding: 10px;"> <h4>Technical specifications</h4> <p>Field data (operating/limit distance) of transponders and readers (all specifications in mm)</p> <p>The field data (unaffected by metal) of the RF300 transponders in connection with RF300 readers is listed in the technical specifications of the RFID overview. The listed technical data are typical values and are valid for a room temperature of +25 °C.</p> <p>For detailed descriptions and ordering data of these RF300 transponders: Refer to the following product nodes.</p> </div>		

Overview



Universal, compact transponder (20 bytes EEPROM + 4 bytes serial number) in button format. Dimensions Ø x H (mm): 27 x 4.

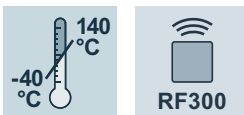

Technical specifications

Article number	6GT2800-1CA00
Product type designation	RF320T transponder
Suitability for operation	RF300
Wireless frequencies	
Operating frequency Rated value	13.56 MHz
Electrical data	
Range maximum	60 mm; range is reader dependent: observe
http://support.automation.siemens.com/WW/view/en/67384964	
Protocol with radio transmission	RF300-specific
Transfer rate with radio transmission maximum	106 kbit/s
Product feature multitag-capable	Yes
Product component Backup battery	No
Memory	
Type of memory	EEPROM
Storage capacity of the user memory	20 byte
Type of memory organization	UID (fixed code) 4 bytes, user memory 20 bytes,
Number of read cycles at ambient temperature < 40 °C maximum	100 000 000 000 000
Number of write cycles at ambient temperature < 40 °C maximum	1 000 000
Data retention time at ambient temperature < 40 °C not less than	10 y
Property of memory	Block-by-block write protection of the user memory
Mechanical data	
Material	Epoxy resin
Color	black
Mounting distance relating to metal surfaces recommended minimum	20 mm

Article number	6GT2800-1CA00
Product type designation	RF320T transponder
Suitability for operation	RF300
Permitted ambient conditions	
Ambient temperature	
• during read/write access	-25 ... +125 °C
• outside the read/write area	-40 ... +140 °C
• during storage	-40 ... +140 °C
Protection class IP	IP67 / IPx9K
Shock resistance	According to DIN EN 60721-3-7 Class 7 M3
Shock acceleration	1 000 m/s ²
Vibrational acceleration	200 m/s ²
Design, dimensions and weight	
Height	4 mm
Diameter	27 mm
Net weight	5 g
Mounting type	M3 screw, gluing
Product properties, functions, components general	
Product feature	
• silicon-free	Yes
• printable	No
Standards, specifications, approvals	
MTBF	1 800 y
Accessories	
Accessories	Mounting support and spacer

RFID systems for the HF range

Transponder (RF300 mode)

RF320T

Selection and ordering data

	Article No.
SIMATIC RF320T transponder 20 bytes EEPROM Ordering quantity 20 units or a multiple thereof.	6GT2800-1CA00
Accessories	
Spacer For MDS D124, MDS D324, MDS D424, MDS D524 and RF320T. Necessary for mounting onto metal surfaces. Diameter = 35 mm, height = 15 mm. Ordering quantity 20 units or a multiple thereof.	6GT2690-0AK00



Dimensional drawings

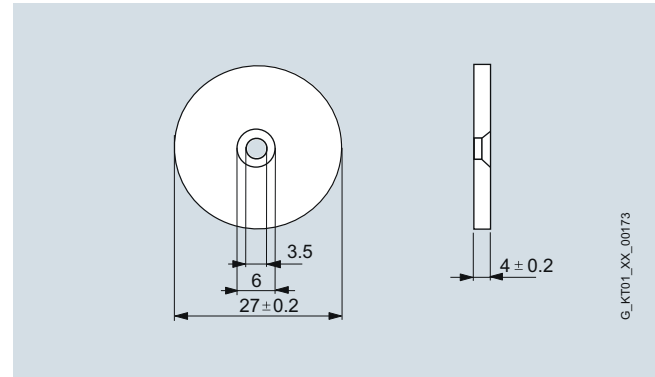

SIMATIC RF320T transponder

Overview



The SIMATIC RF330T is a universal transponder. This compact transponder can be flush-mounted in and on metal. It is thus suitable for directly identifying metallic workpiece holders, workpieces or containers. Thanks to its high IP68/IPx9K degree of protection, it is suitable for use in particularly harsh environments such as the passage through washers.

Technical specifications

Article number	6GT2800-5BA00
Product type designation	RF330T transponder
Suitability for operation	RF300
Wireless frequencies	
Operating frequency Rated value	13.56 MHz
Electrical data	
Range maximum	52 mm; range is reader dependent: observe
http://support.automation.siemens.com/WWW/view/en/67384964	
Protocol with radio transmission	RF300-specific
Transfer rate with radio transmission maximum	106 kbit/s
Product feature multitag-capable	Yes
Product component Backup battery	No
Memory	
Type of memory	FRAM/EEPROM
Storage capacity of the user memory	32 765 byte
Type of memory organization	UID (fixed code) 4 bytes, user memory 32 765 bytes, OTP memory 20 bytes
Number of read cycles at ambient temperature < 40 °C maximum	10 000 000 000
Number of write cycles at ambient temperature < 40 °C maximum	10 000 000 000
Data retention time at ambient temperature < 40 °C not less than	10 y
Property of memory	Block-by-block write protection of the OTP memory

Article number	6GT2800-5BA00
Product type designation	RF330T transponder
Suitability for operation	RF300
Mechanical data	
Material	PPS
Color	black
Tightening torque of the screw for securing the equipment maximum	1.2 Nm
Mounting distance relating to metal surfaces recommended minimum	0 mm
Permitted ambient conditions	
Ambient temperature	
• during read/write access	-25 ... +85 °C
• outside the read/write area	-40 ... +100 °C
• during storage	-40 ... +100 °C
Protection class IP	IP68 / IPx9K
Shock resistance	According to DIN EN 60721-3-7 Class 7 M3
Shock acceleration	500 m/s ²
Vibrational acceleration	200 m/s ²
Design, dimensions and weight	
Height	8 mm
Diameter	30 mm
Net weight	15 g
Mounting type	M4 countersunk screw
Product properties, functions, components general	
Product feature	
• silicon-free	Yes
• printable	No
Standards, specifications, approvals	
MTBF	1 200 y
Accessories	
Accessories	mounting hood

RFID systems for the HF range

Transponder (RF300 mode)

RF330T

Selection and ordering data

	Article No.
SIMATIC RF330T transponder 32 KB FRAM Ordering quantity 10 units or a multiple thereof.	6GT2800-5BA00
Accessories	
Mounting cover Length = 50 mm, height = 10 mm, temperature range up to 100 °C, ordering quantity 10 units or a multiple thereof.	6GT2690-0AE00

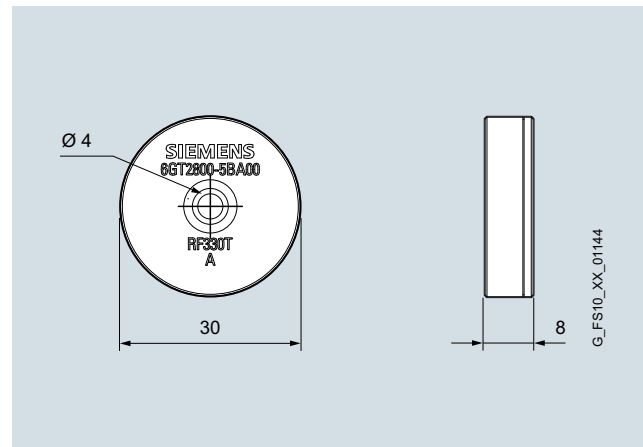
**Dimensional drawings**

SIMATIC RF330T transponder

2

Overview



Universal transponder, especially suitable for small workpiece holders. The transponder can be mounted directly onto metal surfaces.



Technical specifications

	6GT2800-4BB00	6GT2800-5BB00
Article number	6GT2800-4BB00	6GT2800-5BB00
Product type designation	RF340T transponder	RF340T transponder
Suitability for operation	RF300	RF300
Wireless frequencies		
Operating frequency Rated value	13.56 MHz	13.56 MHz
Electrical data		
Range maximum	105 mm; range is reader dependent: observe http://support.automation.siemens.com/WW/view/en/67384964	
Protocol with radio transmission	RF300-specific	RF300-specific
Transfer rate with radio transmission maximum	106 kbit/s	106 kbit/s
Product feature multitag-capable	Yes	Yes
Product component Backup battery	No	No
Memory		
Type of memory	FRAM/EEPROM	FRAM/EEPROM
Storage capacity of the user memory	8 189 byte	32 765 byte
Type of memory organization	UID (fixed code) 4 bytes, user memory 8 189 bytes, OTP memory 20 bytes	UID (fixed code) 4 bytes, user memory 32 765 bytes, OTP memory 20 bytes
Number of read cycles at ambient temperature < 40 °C maximum	10 000 000 000	10 000 000 000
Number of write cycles at ambient temperature < 40 °C maximum	10 000 000 000	10 000 000 000
Data retention time at ambient temperature < 40 °C not less than	10 y	10 y
Property of memory	Block-by-block write protection of the OTP memory	Block-by-block write protection of the OTP memory

RFID systems for the HF range

Transponder (RF300 mode)

RF340T

	6GT2800-4BB00	6GT2800-5BB00
Article number	6GT2800-4BB00	6GT2800-5BB00
Product type designation	RF340T transponder	RF340T transponder
Suitability for operation	RF300	RF300
Mechanical data		
Material	PA12	PA12
Color	anthracite	anthracite
Mounting distance relating to metal surfaces recommended minimum	0 mm	0 mm
Permitted ambient conditions		
Ambient temperature		
• during read/write access	-25 ... +85 °C	-25 ... +85 °C
• outside the read/write area	-40 ... +85 °C	-40 ... +85 °C
• during storage	-40 ... +85 °C	-40 ... +85 °C
Protection class IP	IP67 / IPx9K	IP67 / IPx9K
Shock resistance	According to DIN EN 60721-3-7 Class 7 M3	According to DIN EN 60721-3-7 Class 7 M3
Shock acceleration	500 m/s ²	500 m/s ²
Vibrational acceleration	200 m/s ²	200 m/s ²
Design, dimensions and weight		
Width	25 mm	25 mm
Height	15 mm	15 mm
Depth	48 mm	48 mm
Net weight	25 g	25 g
Mounting type	2 x M3 screws	2 x M3 screws
Product properties, functions, components general		
Product feature		
• silicon-free	Yes	Yes
• printable	No	No
Standards, specifications, approvals		
MTBF	1 200 y	1 200 y

Selection and ordering data

	Article No.
SIMATIC RF340T transponder	
• 8 KB FRAM Ordering quantity 5 units or a multiple thereof.	6GT2800-4BB00
• 32 KB FRAM Order quantity 5 units or a multiple thereof.	6GT2800-5BB00

Dimensional drawings

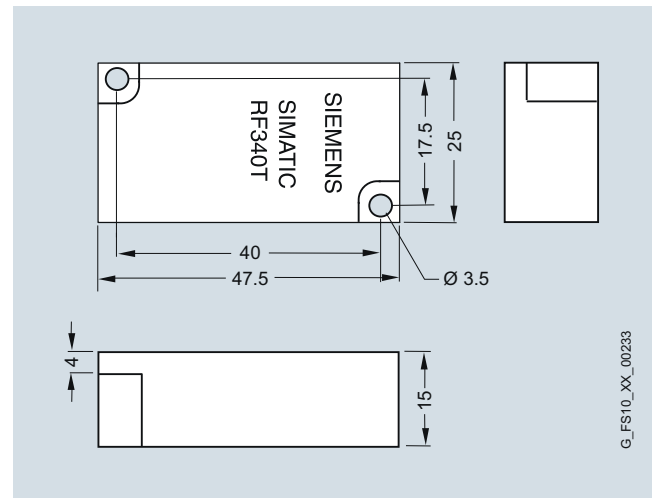

SIMATIC RF340T transponder

G_FS10_XX_00233

Overview



Universal transponder. The transponder can be mounted directly onto metal surfaces.

Technical specifications

Article number	6GT2800-5BD00
Product type designation	RF350T transponder
Suitability for operation	RF300
Wireless frequencies	
Operating frequency Rated value	13.56 MHz
Electrical data	
Range maximum	125 mm; range is reader dependent: observe http://support.automation.siemens.com/WW/view/en/67384964
Protocol with radio transmission	RF300-specific
Transfer rate with radio transmission maximum	106 kbit/s
Product feature multitag-capable	Yes
Product component Backup battery	No
Memory	
Type of memory	FRAM/EEPROM
Storage capacity of the user memory	32 765 byte
Type of memory organization	UID (fixed code) 4 bytes, user memory 32 765 bytes, OTP memory 20 bytes
Number of read cycles at ambient temperature < 40 °C maximum	10 000 000 000
Number of write cycles at ambient temperature < 40 °C maximum	10 000 000 000
Data retention time at ambient temperature < 40 °C not less than	10 y
Property of memory	Block-by-block write protection of the OTP memory

Article number	6GT2800-5BD00
Product type designation	RF350T transponder
Suitability for operation	RF300
Mechanical data	
Material	PA12
Color	anthracite
Mounting distance relating to metal surfaces recommended minimum	0 mm
Permitted ambient conditions	
Ambient temperature	
• during read/write access	-25 ... +85 °C
• outside the read/write area	-40 ... +85 °C
• during storage	-40 ... +85 °C
Protection class IP	IP68
Shock resistance	According to DIN EN 60721-3-7 Class 7 M3
Shock acceleration	500 m/s ²
Vibrational acceleration	200 m/s ²
Design, dimensions and weight	
Width	50 mm
Height	20 mm
Depth	50 mm
Net weight	25 g
Mounting type	2 x M4 screws
Product properties, functions, components general	
Product feature	
• silicon-free	Yes
• printable	No
Standards, specifications, approvals	
MTBF	1 200 y

Selection and ordering data

	Article No.
SIMATIC RF350T transponder	6GT2800-5BD00
32 Kbyte FRAM	

RFID systems for the HF range

Transponder (RF300 mode)

RF350T

Dimensional drawings

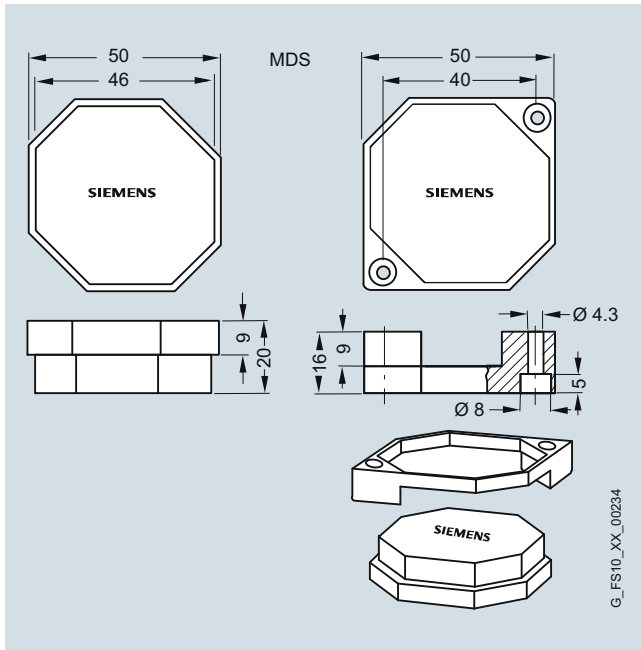

Left: Transponder SIMATIC RF350T.

Top right: Mounting frame.

Lower right: Installation diagram. The transponder can be mounted with the mounting frame as shown.

Overview

Universal transponder in credit card format. The transponder can be mounted on metal with spacers.

			6GT2800-4AC00
8 Kbyte	RF300	Speed	
			6GT2800-5AC00
32 Kbyte	RF300	Speed	

Technical specifications

	6GT2800-4AC00	6GT2800-5AC00
Article number	6GT2800-4AC00	6GT2800-5AC00
Product type designation	RF360T transponder	RF360T transponder
Suitability for operation	RF300	RF300
Wireless frequencies		
Operating frequency Rated value	13.56 MHz	13.56 MHz
Electrical data		
Range maximum	150 mm; range is reader dependent: observe http://support.automation.siemens.com/WW/view/en/67384964	
Protocol with radio transmission	RF300-specific	RF300-specific
Transfer rate with radio transmission maximum	106 kbit/s	106 kbit/s
Product feature multitag-capable	Yes	Yes
Product component Backup battery	No	No
Memory		
Type of memory	FRAM/EEPROM	FRAM/EEPROM
Storage capacity of the user memory	8 189 byte	32 765 byte
Type of memory organization	UID (fixed code) 4 bytes, user memory 8 189 bytes, OTP memory 20 bytes	UID (fixed code) 4 bytes, user memory 32 765 bytes, OTP memory 20 bytes
Number of read cycles at ambient temperature < 40 °C maximum	10 000 000 000	10 000 000 000
Number of write cycles at ambient temperature < 40 °C maximum	10 000 000 000	10 000 000 000
Data retention time at ambient temperature < 40 °C not less than	10 y	10 y
Property of memory	Block-by-block write protection of the OTP memory	Block-by-block write protection of the OTP memory
Mechanical data		
Material	Epoxy resin	Epoxy resin
Color	anthracite	anthracite
Mounting distance relating to metal surfaces recommended minimum	20 mm	20 mm



RFID systems for the HF range

Transponder (RF300 mode)

RF360T

Article number	6GT2800-4AC00	6GT2800-5AC00
Product type designation	RF360T transponder	RF360T transponder
Suitability for operation	RF300	RF300
Permitted ambient conditions		
Ambient temperature		
• during read/write access	-25 ... +75 °C	-25 ... +75 °C
• outside the read/write area	-40 ... +85 °C	-40 ... +85 °C
• during storage	-40 ... +85 °C	-40 ... +85 °C
Protection class IP	IP67	IP67
Shock resistance	According to DIN EN 60721-3-7 Class 7 M3	According to DIN EN 60721-3-7 Class 7 M3
Shock acceleration	500 m/s ²	500 m/s ²
Vibrational acceleration	200 m/s ²	200 m/s ²
Resistance to mechanical stress	Continuous torsion and bending stress not permissible	Continuous torsion and bending stress not permissible
Design, dimensions and weight		
Width	55 mm	55 mm
Height	2.5 mm	2.5 mm
Depth	86 mm	86 mm
Net weight	25 g	25 g
Mounting type	2 x M3 screws, mounting bag (see accessories)	2 x M3 screws, mounting bag (see accessories)
Product properties, functions, components general		
Product feature		
• silicon-free	Yes	Yes
• printable	No	No
Standards, specifications, approvals		
MTBF	1 200 y	1 200 y
Accessories	Fixing strap, holder	Fixing strap, holder

Selection and ordering data

	Article No.
SIMATIC RF360T transponder	
• 8 Kbyte FRAM Ordering quantity 10 units or a multiple thereof..	6GT2800-4AC00
• 32 Kbyte FRAM Ordering quantity 10 units or a multiple thereof.	6GT2800-5AC00
Accessories	
Fixing pocket	6GT2190-0AB00
For SIMATIC RF360T, only usable together with spacer 6GT2190-0AA00. Ordering quantity 50 units or a multiple thereof.	
	
Spacer	6GT2190-0AA00
For fixing pocket (6GT2190-0AB00), thickness 20 mm. The purpose of the spacer is to maintain the recommended distance to the metal when installing the transponder. Ordering quantity 50 units or a multiple thereof.	
	

Dimensional drawings

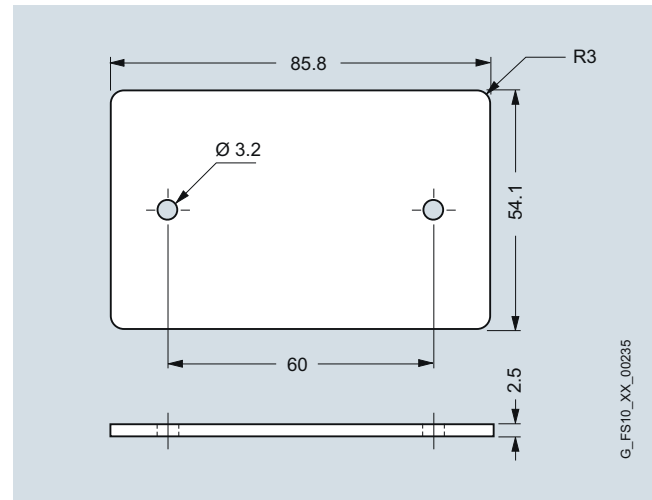

SIMATIC RF360T transponder

Overview

Universal transponder in cuboid form. The transponder can be mounted directly onto metal surfaces.

				6GT2800-5BE00
32 Kbyte	METAL	RF300	Speed	
				6GT2800-6BE00
64 Kbyte	METAL	RF300	Speed	

Technical specifications

	6GT2800-5BE00	6GT2800-6BE00
Article number	6GT2800-5BE00	6GT2800-6BE00
Product type designation	RF370T transponder	RF370T transponder
Suitability for operation	RF300	RF300
Wireless frequencies		
Operating frequency Rated value	13.56 MHz	13.56 MHz
Electrical data		
Range maximum	135 mm; range is reader dependent: observe http://support.automation.siemens.com/WW/view/en/67384964	
Protocol with radio transmission	RF300-specific	RF300-specific
Transfer rate with radio transmission maximum	106 kbit/s	106 kbit/s
Product feature multitag-capable	Yes	Yes
Product component Backup battery	No	No
Memory		
Type of memory	FRAM/EEPROM	FRAM/EEPROM
Storage capacity of the user memory	32 765 byte	65 277 byte
Type of memory organization	UID (fixed code) 4 bytes, user memory 32 765 bytes, OTP memory 20 bytes	UID (fixed code) 4 bytes, user memory 65 277 bytes, OTP memory 20 bytes
Number of read cycles at ambient temperature < 40 °C maximum	10 000 000 000	10 000 000 000
Number of write cycles at ambient temperature < 40 °C maximum	10 000 000 000	10 000 000 000
Data retention time at ambient temperature < 40 °C not less than	10 y	10 y
Property of memory	Block-by-block write protection of the OTP memory	Block-by-block write protection of the OTP memory

RFID systems for the HF range

Transponder (RF300 mode)

RF370T

Article number	6GT2800-5BE00	6GT2800-6BE00
Product type designation	RF370T transponder	RF370T transponder
Suitability for operation	RF300	RF300
Mechanical data		
Material	PA12	PA12
Color	anthracite	anthracite
Tightening torque of the screw for securing the equipment maximum	1.2 Nm	1.2 Nm
Mounting distance relating to metal surfaces recommended minimum	0 mm	0 mm
Permitted ambient conditions		
Ambient temperature		
• during read/write access	-25 ... +85 °C	-25 ... +85 °C
• outside the read/write area	-40 ... +85 °C	-40 ... +85 °C
• during storage	-40 ... +85 °C	-40 ... +85 °C
Protection class IP	IP68	IP68
Shock resistance	According to DIN EN 60721-3-7 Class 7 M3	According to DIN EN 60721-3-7 Class 7 M3
Shock acceleration	500 m/s ²	500 m/s ²
Vibrational acceleration	200 m/s ²	200 m/s ²
Design, dimensions and weight		
Width	75 mm	75 mm
Height	41 mm	41 mm
Depth	75 mm	75 mm
Net weight	200 g	200 g
Mounting type	2 x M5 screws	2 x M5 screws
Product properties, functions, components general		
Product feature		
• silicon-free	Yes	Yes
• printable	No	No
Standards, specifications, approvals		
MTBF	1 200 y	1 200 y

Selection and ordering data

	Article No.
SIMATIC RF370T transponder	
• 32 KB FRAM	6GT2800-5BE00
• 64 KB FRAM	6GT2800-6BE00

Dimensional drawings

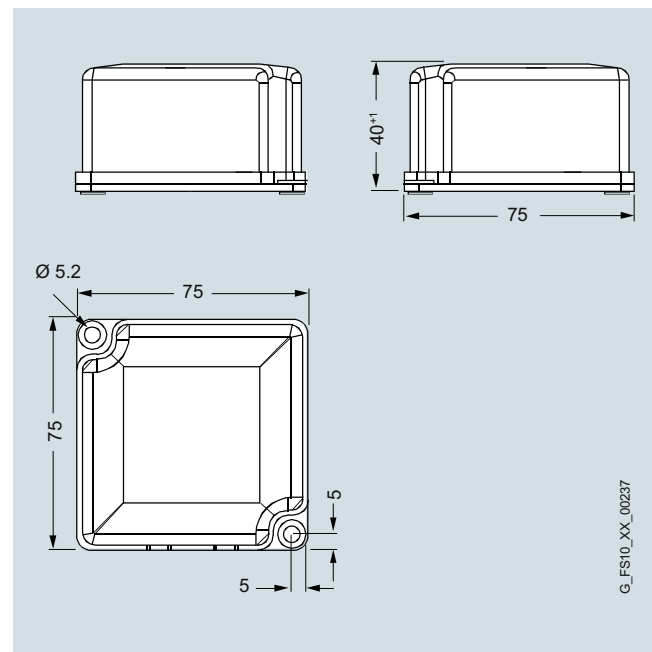

SIMATIC RF370T transponder

Overview



Heat-resistant transponder, designed for skid identification in paint shops, temperature range up to +220 °C (cyclic).

Application

Typical applications are:

- Primer application, cataphoresis with the associated drying ovens
- Outer paint coating area with drying ovens
- Washing area with temperatures > +85°C

2

Mode of operation

Cyclic operation of the transponder at temperatures > 100 °C

At ambient temperatures between +110 °C and +220 °C, care must be taken to ensure that the internal temperature of the SIMATIC RF380T does not exceed the critical threshold of +110 °C. Each heating phase must therefore be followed by a cooling phase. Some limit cycles are listed in the table below.

Heating up		Cooling down	
Temperature	Time	Temperature	Time
200 °C	2 h	25 °C	> 8 h
200 °C	1 h	25 °C	> 2 h
190 °C	2 h	25 °C	> 7 h
190 °C	1 h	25 °C	> 1 h 45 min
180 °C	2 h	25 °C	> 5 h 30 min
180 °C	2 h	25 °C	> 4 h 30 min

A temperature calculation tool computes the temperature curve for the heat-proof SIMATIC RF380T transponder (see DVD "RFID Systems Software & Documentation", Article No. 6GT2080-2AA20).

RFID systems for the HF range

Transponder (RF300 mode)

RF380T

Technical specifications

Article number	6GT2800-5DA00
Product type designation	RF380T transponder
Suitability for operation	RF300
Wireless frequencies	
Operating frequency Rated value	13.56 MHz
Electrical data	
Range maximum	160 mm; range is reader dependent: observe
http://support.automation.siemens.com/WW/view/en/67384964	
Protocol with radio transmission	RF300-specific
Transfer rate with radio transmission maximum	106 kbit/s
Product feature multitag-capable	Yes
Product component Backup battery	No
Memory	
Type of memory	FRAM/EEPROM
Storage capacity of the user memory	32 765 byte
Type of memory organization	UID (fixed code) 4 bytes, memory 32 765 bytes, OTP memory 20 bytes
Number of read cycles at ambient temperature < 40 °C maximum	10 000 000 000
Number of write cycles at ambient temperature < 40 °C maximum	10 000 000 000
Data retention time at ambient temperature < 40 °C not less than	10 y
Property of memory	Block-by-block write protection of the OTP memory
Mechanical data	
Material	PPS
Color	brown
Mounting distance relating to metal surfaces recommended minimum	0 mm
Permitted ambient conditions	
Ambient temperature	
• during read/write access	-25 ... +110 °C
• outside the read/write area	-40 ... +220 °C
• during storage	-40 ... +110 °C
Ambient condition for operation	Cyclic operation at ambient temperature > 110 °C
Protection class IP	IP68
Shock resistance	According to DIN EN 60721-3-7 Class 7 M3
Shock acceleration	500 m/s ²
Vibrational acceleration	200 m/s ²
Design, dimensions and weight	
Height	83 mm
Diameter	114 mm
Net weight	900 g
Mounting type	mount (see accessories)
Product properties, functions, components general	
Product feature	
• silicon-free	Yes
• printable	No
Standards, specifications, approvals	
Certificate of suitability	Ex: II 3G Ex nC IIB T5
MTBF	1 200 y
Accessories	
Accessories	Skid holder, shrouding cover, universal holder

Selection and ordering data

	Article No.
Transponder SIMATIC RF380T	6GT2800-5DA00
With 32 KB FRAM	
Accessories	
Skid support for SIMATIC RF380T	6GT2090-0QA00
Short type	
	
Universal support	6GT2590-0QA00
For SIMATIC RF380T, e.g. for attaching to the body.	
	
Shrouding cover	6GT2090-0QB00
For skid support.	
	

Dimensional drawings

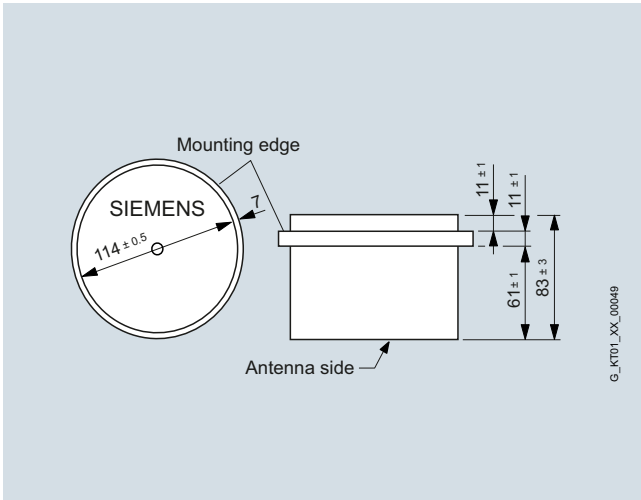

SIMATIC RF380T transponder

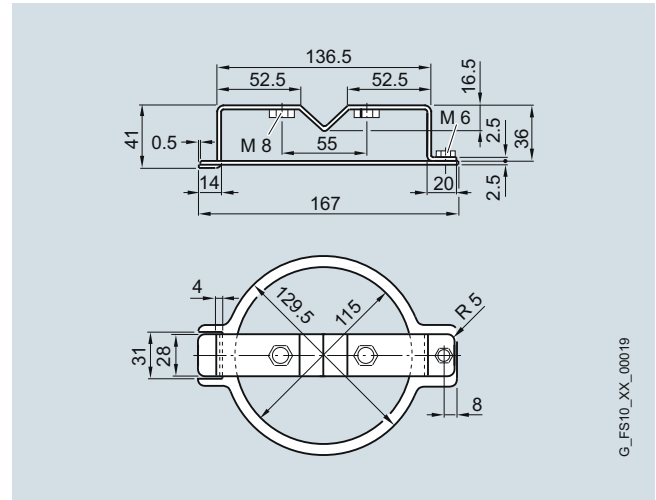

Universal holder for RF380T

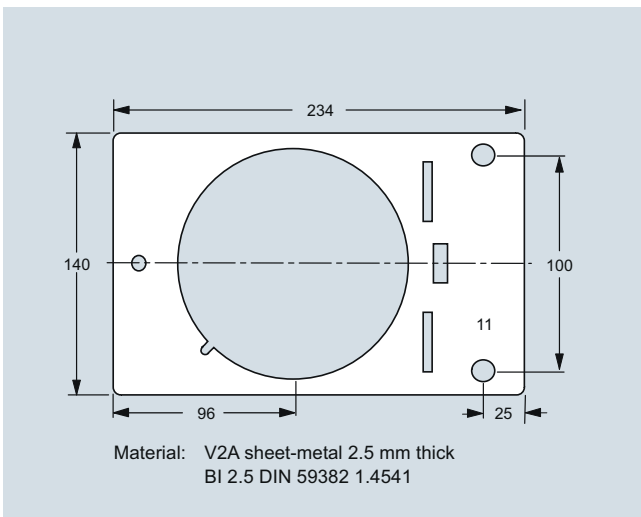

Material: V2A sheet-metal 2.5 mm thick
BI 2.5 DIN 59382 1.4541

Skid holder for RF380T

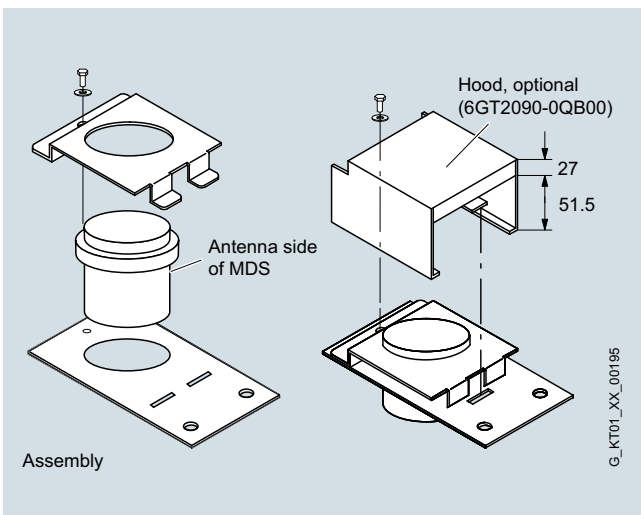

Skid holder, shrouding cover for RF380T

RFID systems for the HF range

SIMATIC RF200

Introduction

Overview



The RFID system SIMATIC RF200 is, thanks to its compact and low-cost reader, particularly suitable for use in industrial production in the areas of small assembly lines and intralogistics.

With RF200, identification tasks of medium-performance in the RF range (13.56 MHz, ISO 15693) can be implemented extremely cost effectively. RF200 readers can be operated with all ISO transponders.

The communication modules that can be used for all MOBY and SIMATIC RF systems (ASM 456, ASM 475, SIMATIC RF1xxC) are available for connecting to SIMATIC S7, PROFIBUS, PROFINET, Ethernet/IP and TCP/IP (XML).

IO-Link

For simple identification tasks (e.g. reading an identification number) the RF210R/RF220R//RF240R/RF250R/RF260R readers are available in an interface version for IO-Link. With the help of this standardized interface it is extremely easy and economical to integrate the data automatically read by the reader into the automation level. The SIMATIC RF200 readers can be connected to the controllers of many well-known suppliers of automation solutions through an appropriate IO-Link master module.

Siemens offers IO-Link master modules for S7-1200, ET 200S, ET 200SP, ET 200AL and ET 200eco PN. In this way, IO-Link is seamlessly integrated into the established PROFINET and PROFIBUS field buses and into the world of Totally Integrated Automation (TIA Portal).

The Siemens master modules allow up to four SIMATIC RF200 IO-Link readers to be connected.

The essential features of IO-Link are:

- Ease of use: No RFID-specific programming is necessary, ideal for RFID beginners.
- Particularly low channel costs per reading point (reader + IO-Link master interface).
- Openness through standardization: Many well-known manufacturers offer IO-Link masters.

The SIMATIC RF200 identification system offers the following features:

- 13.56 MHz operating frequency (operation according to ISO 15693).
- Passive (without battery), maintenance-free transponders (MDS Dxxx) with memory capacities up to 8 KB FRAM.
- Rugged, compact components with IP67 degree of protection.
- Easy integration into SIMATIC, PROFIBUS, PROFINET and TCP/IP.
- Reader versions with RS422, RS232 or IO-Link.

Benefits

g e t Designed for Industry

- Price-optimized and compact, space-saving components.
- Operation with the attractively priced and battery-free ISO 15693 transponders for low investment and operating costs.
- Flexible and economic solutions thanks to the complete and scalable portfolio for the field of industrial identification.
- Simplified engineering, commissioning, diagnostics and maintenance through seamless integration into Totally Integrated Automation:
 - Integrated bus connection to an automation system, such as SIMATIC, SIMOTION or SINUMERIK via communication modules with PROFIBUS and PROFINET.
 - Simple S7 software integration via ready-to-use function blocks.
- High investment security thanks to:
 - Open ISO 15693 standard.
 - Software compatibility between the RFID systems of Siemens.
 - Standardized communication interfaces.
- Openness through connection options to various bus systems from different manufacturers and PC environments via communication modules, RS232 or IO-Link.
- Worldwide Service and Support.
- tionsmodule, RS232 oder IO-Link.
- Weltweiter Service und Support.

Application

The RFID system SIMATIC RF200 is primarily used for non-contact identification of containers, pallets and workpiece holders where the demands on performance (data transmission rate, memory volume) satisfy the ISO 15693 standard.

The main application areas for SIMATIC RF200 are:

- Assembly and handling systems, assembly lines (identification of workpiece carriers), especially small assembly lines.
- Production logistics (material flow control, identification of containers and other vessels), intralogistics.
- Parts identification (the transponder is attached to the products or pallets).
- Conveyor systems (e.g. suspended monorail).

Design

Due to their compact design and the integrated antenna, SIMATIC RF200 readers are suitable for mounting in confined spaces, e.g. in small assembly lines or in intralogistics.

The high IP67 degree of protection of the SIMATIC RF200 reader enables it to be used in harsh industrial environments.

Each SIMATIC RF200 reader has a multicolor LED which indicates the function and status of the reader on-site, as well as the presence of a transponder.

The interface to the automation level can be implemented by means of communication modules. For quick and easy cabling, pre-assembled cables with M12 plug-in connectors are available in various lengths.

Transponders compliant with ISO 15693 are used as mobile data carriers.

Transponders suitable for a wide variety of different requirements can be selected from an extensive range: For example, low-cost SmartLabels in rugged credit card format, or screw-fit transponders that can be attached by robots.

The transponders are attached to the object to be identified, e.g. by means of screws, adhesive or pre-assembled spacer.

Function

All of the SIMATIC RF200 readers are suitable for reliable reading and writing tasks in the HF range of 13.56 MHz. The SIMATIC RF200 IO-Link readers are designed for simple identification tasks.

The readers are connected (via an RS422 interface) to the automation level (e.g. SIMATIC S7) by means of communication modules over standard fieldbuses (e.g. PROFIBUS or PROFINET).

User-friendly function blocks are available for the S7 programming.

In the event of an error, the S7 application receives a detailed error message from the communication module via the function block.

In addition, there are the SIMATIC RF240R, RF250R and RF260R readers with an RS232 interface for connection to the PC or to SIMATIC S7-1200.

The SIMATIC RF210R, RF220R, RF240R, RF250R and RF260R readers are available as versions with IO-Link interface.

Integration

A wide range of communication modules, function blocks, as well as high-performance drivers and function libraries permits easy and quick integration into the application.

And best of all: SIMATIC RF200 is part of Totally Integrated Automation (TIA) and can be integrated easily and cost-effectively into the SIMATIC world.

The IO-Link versions of the RF200 readers are integrated into the control level with the help of standardized IO-Link masters.

For more details on the connection possibilities, see Chapter 5 "Communication Modules".

SIMATIC Ident Configuration Guide

Here is a compact configuration tool for setting up RFID systems:

<http://support.automation.siemens.com/WW/view/en/67384964>

Technical specifications

RFID system	SIMATIC RF200
Transmission frequency	13.56 MHz
Maximum range	650 mm
Protocol (air interface)	<ul style="list-style-type: none"> • ISO 15693 • ISO 18000-3
Approvals ¹⁾	<ul style="list-style-type: none"> • EN 300330, 301489, CE • FCC Part 15 • UL/CSA
Memory capacity	max. 992 bytes (EEPROM) / 8 192 bytes (FRAM)
Data transfer rate, reader – transponder (not for IO-Link)	<ul style="list-style-type: none"> • Read: Max. 1.5 kbyte/s • Write: Max. 1.5 kbyte/s
Transmission time per byte for user data (IO-Link versions)	Typ. 40 ms
Multitag/Bulk capability	With RF290R reader only
Special features	<ul style="list-style-type: none"> • Particularly compact designs • For particularly low-cost RFID solutions • IO-Link for simple identification tasks









¹⁾ All current wireless approvals can be found on the Internet at: <http://www.siemens.com/rfid-approvals>

RFID systems for the HF range

SIMATIC RF200 readers

Introduction

Overview

Readers	Feature	Page	Readers	Feature	Page
RF210R 	M18 reader with integrated antenna.	2/79	RF250R 	Extremely small compact reader for connecting external antennas (ANT 3, 8, 12, 18 and 30).	2/90
RF210M 	Handheld reader with integrated RF210R reader.	2/82	RF260R 	Compact reader with integrated antenna.	2/95
RF220R 	M30 reader with integrated antenna.	2/83	RF290R 	High-performance reader for connecting external antennas (ANT D5, D6, D10).	2/99
RF240R 	Very small compact reader with integrated antenna..	2/86	RF350M 	Handheld terminal with integrated or external read/write antenna.	2/117

Overview



SIMATIC RF210R is an M18 reader with integrated antenna. Its extremely compact design makes it ideal for use on small assembly lines.

This reader has either

- an RS422 interface with 3964R transmission procedure for connection to RFID communication modules (see Chapter 5),
- or a standardized IO-Link interface for connection to IO-Link master modules from Siemens or third parties.

Thanks to its high degree of protection and rugged design, the SIMATIC RF210R reader enables problem-free use even under the toughest industrial conditions. Connection is by means of either an 8-pin M12 plug-in connector (RS422 version) or a 4-pin M12 plug-in connector (IO-Link version).

The reader is operated with ISO 15693-compatible transponders.

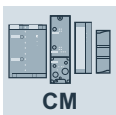

6GT2821-1AC10



6GT2821-1AC32

Design

Minimum distance from reader to reader

SIMATIC RF210R	≥ 100 mm
----------------	----------

Technical specifications

	6GT2821-1AC10	6GT2821-1AC32
Article number	6GT2821-1AC10	6GT2821-1AC32
Product type designation	RF210R reader	RF210R reader IO-Link
Suitability for operation	ISO 15693 transponders (MDS Dxxx), for connecting to communication modules	ISO 15693 transponders (MDS Dxxx), for connecting to an IO-Link master
Wireless frequencies		
Operating frequency Rated value	13.56 MHz	13.56 MHz
Electrical data		
Range maximum	20 mm; Range is dependent on transponder type: observe http://support.automation.siemens.com/WW/view/en/67384964	
Protocol with radio transmission	ISO 15693, ISO 18000-3	ISO 15693, ISO 18000-3
Transfer rate with radio transmission maximum	26.5 kbit/s	26.5 kbit/s
Product feature multitag-capable	No	No
Transfer rate at the point-to-point connection serial maximum	115.2 kbit/s	38.4 kbit/s
Transmission time for user data		
• for write access per byte typical	0.6 ms	40 ms
• for read access per byte typical	0.6 ms	40 ms
Interfaces		
Standard for interfaces for communication	RS422	IO-Link
Type of electrical connection	M12, 8-pin	M12, 4-pin
Mechanical data		
Material	Brass, nickel-plated / PBT	Brass, nickel-plated / PBT
Color	silver/pastel turquoise	silver/pastel turquoise
Tightening torque of the screw for securing the equipment maximum	20 Nm	20 Nm
Mounting distance relating to metal surfaces recommended minimum	0 mm	0 mm





RFID systems for the HF range

SIMATIC RF200 readers

RF210R

	6GT2821-1AC10	6GT2821-1AC32
Article number	RF210R reader	RF210R reader IO-Link
Product type designation	RF210R reader	RF210R reader IO-Link
Supply voltage, current consumption, power loss		
Supply voltage		
• at DC Rated value	24 V	24 V
• at DC	20.4 ... 28.8 V	20.4 ... 28.8 V
Consumed current at 24 V DC		
• typical	0.05 A	0.05 A
Permitted ambient conditions		
Ambient temperature		
• during operation	-20 ... +70 °C	-20 ... +70 °C
• during storage	-25 ... +80 °C	-25 ... +80 °C
• during transport	-25 ... +80 °C	-25 ... +80 °C
Protection class IP	IP67	IP67
Shock resistance	EN 60721-3-7, Class 7 M2	EN 60721-3-7, Class 7 M2
Shock acceleration	500 m/s ²	500 m/s ²
Vibrational acceleration	200 m/s ²	200 m/s ²
Design, dimensions and weight		
Height	83 mm	83 mm
Diameter	18 mm	18 mm
Net weight	0.065 kg	0.065 kg
Mounting type	2 x M18 nuts (included in scope of supply)	2 x M18 nuts (included in scope of supply)
Cable length		
• for RS422 interface maximum	1 000 m	
• between master and IO-Link device maximum		20 m
Product properties, functions, components general		
Display version	3-color LED	3-color LED
Product feature silicon-free	Yes	Yes
Standards, specifications, approvals		
Certificate of suitability	Wireless according to R&TTE guidelines EN300 330 and EN 301489, FCC, UL/CSA	Wireless according to R&TTE guidelines EN300 330 and EN 301489, FCC, UL/CSA
MTBF	505 y	505 y
Accessories		
Accessories		IO-Link master, IO-Link connecting cables

Selection and ordering data

	Article No.
SIMATIC RF210R reader (RS422)	6GT2821-1AC10
SIMATIC RF210R reader (IO-Link)	6GT2821-1AC32
Accessories	
Note: All connection options can be found in Chapter 5, "Communication Modules".	
IO-Link master SM 1278 For SIMATIC S7-1200, for 4 readers.	6ES7278-4BD32-0XB0
	
IO-Link master 4SI For SIMATIC ET 200S, for 4 readers.	6ES7138-4GA50-0AB0
	
IO-Link master For SIMATIC ET 200eco PN, for 4 readers.	6ES7148-6JA00-0AB0
	
IO-Link master For ET 200SP, for 4 readers.	6ES7137-6BD00-0BA0
	
IO-Link master For ET 200AL, for 4 readers.	6ES7147-5JD00-0BA0
	

Article No.

IO-Link connecting cables



- between IO-Link master and reader, with M12 plug on the IO-Link master, open end, 4-pole, 5 m
- between IO-Link master and reader, with M12 plug on the IO-Link master, open end, 4-pole, 10 m
- between IO-Link master and reader, with M12 plug at both ends, 4-pole, 5 m
- between IO-Link master and reader, with M12 plug at both ends, 4-pole, 10 m

6GT2891-4LH50**6GT2891-4LN10****6GT2891-4MH50****6GT2891-4MN10****DVD „RFID-Systems Software & Documentation“****6GT2080-2AA20**

Dimensional drawings

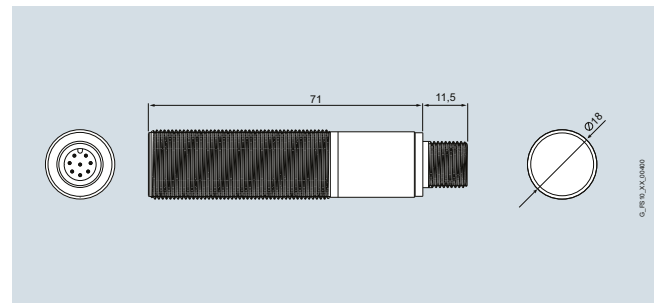

SIMATIC RF210R reader

More information

All current wireless approvals can be found on the Internet at:
<http://www.siemens.com/rfid-approvals>

RFID systems for the HF range

SIMATIC RF200 readers

RF210M mobile handheld terminal

Overview

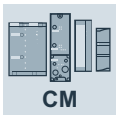

The field-proven RF210R M18 reader is integrated into the SIMATIC RF210M mobile handheld reader. It has been designed for manual workplaces and reworking stations for commissioning, as well as for tracking and tracing tasks and tool identification.

The handheld reader has an RS422 interface with 3964R transmission procedure for connection to RFID communication modules. Connection is via an 8-pole M12 plug-in connector (RS422 variant).

The handheld reader is operated with ISO 15693-compatible transponders.

Technical specifications

Article number	6GT2823-0AA00
Product type designation	RF210M hand-held reader
Suitability for operation	RF200/ISO 15693 transponders, to connect to communication modules via spiral cable with usable length of 2 m to 3.5 m
Range	0 ... 20 mm
Wireless frequencies	
Operating frequency Rated value	13.56 MHz
Electrical data	
Protocol with radio transmission	ISO 15693, ISO 18000-3
Transfer rate with radio transmission maximum	26.5 kbit/s
Product feature multitag-capable	No
Supply voltage, current consumption, power loss	
Type of current supply	24 V via communication module
Type of battery	-
Permitted ambient conditions	
Ambient temperature	
• during operation	-20 ... +50 °C
• during storage	-25 ... +60 °C
Height of fall maximum	1.5 m
Protection class IP	IP54

Article number	6GT2823-0AA00
Product type designation	RF210M hand-held reader
Design, dimensions and weight	
Depth	26 mm
Height	140 mm
Width	195 mm
Net weight	0.46 kg
Product properties, functions, components general	
Design of the display	3 color LED
Design of the interface	M12 8-pole with RS422 at spiral cable, which is permanently fixed to the reader
Product functions management, configuration	
Product function of the software	Function blocks for execution of ISO15693 transponders
Type of programming	Function blocks FB 45/55, ident profile
Standards, specifications, approvals	
Certificate of suitability	Wireless according to R&TTE guidelines EN300 330 and EN 301489, FCC, UL/CSA

Selection and ordering data

	Article No.
SIMATIC RF210M handheld reader (RS422)	6GT2823-0AA00
Accessories	
Note: All connection options can be found in Chapter 5, "Communication Modules".	
DVD „RFID-Systems Software & Documentation“	6GT2080-2AA20

Dimensional drawings

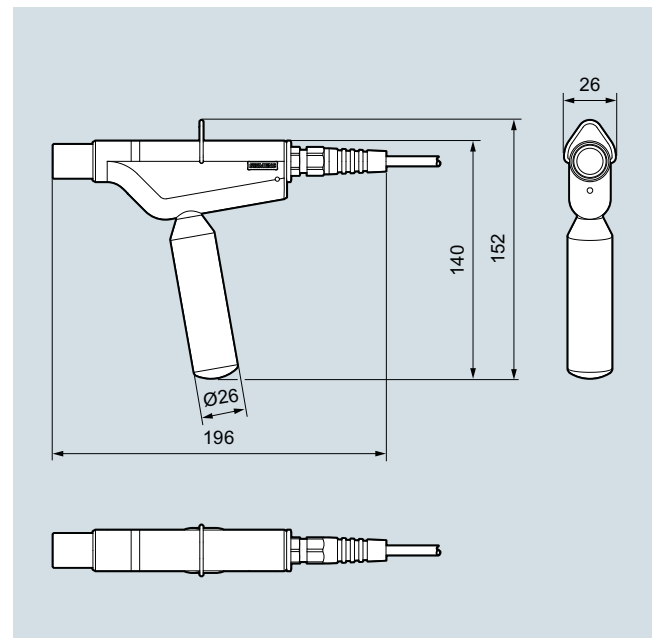

SIMATIC RF210M handheld reader

More information

All current wireless approvals can be found on the Internet at: <http://www.siemens.com/rfid-approvals>

Overview

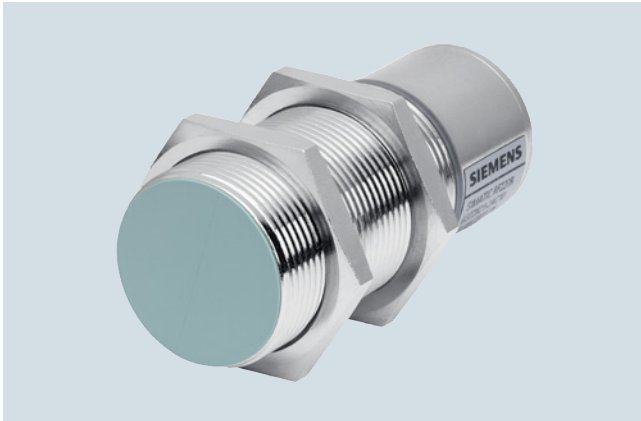

SIMATIC RF220R is an M30 reader with integrated antenna. Its compact design makes it ideal for use in small assembly lines which require a slightly higher range.

This reader has either

- an RS422 interface with 3964R transmission procedure for connection to RFID communication modules (see Chapter 5),
- or a standardized IO-Link interface for connection to IO-Link master modules from Siemens or third parties.

Thanks to its high degree of protection and rugged design, the SIMATIC RF220R reader enables problem-free use even under the toughest industrial conditions. Connection is by means of either an 8-pin M12 plug-in connector (RS422 version) or a 4-pin M12 plug-in connector (IO-Link version).

The reader is operated with ISO 15693-compatible transponders.

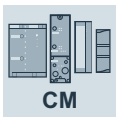

6GT2821-2AC10



6GT2821-2AC32

Design

Minimum distance from reader to reader

SIMATIC RF220R ≥ 150 mm

Technical specifications

	6GT2821-2AC10	6GT2821-2AC32
Article number	6GT2821-2AC10	6GT2821-2AC32
Product type designation	RF220R reader	RF220R reader IO-Link
Suitability for operation	ISO 15693 transponders (MDS Dxxx), for connecting to communication modules	ISO 15693 transponders (MDS Dxxx), for connecting to an IO-Link Master
Wireless frequencies		
Operating frequency Rated value	13.56 MHz	13.56 MHz
Electrical data		
Range maximum	35 mm; Range is dependent on transponder type: observe http://support.automation.siemens.com/WW/view/en/67384964	
Protocol with radio transmission	ISO 15693, ISO 18000-3	ISO 15693, ISO 18000-3
Transfer rate with radio transmission maximum	26.5 kbit/s	26.5 kbit/s
Product feature multitag-capable	No	No
Transfer rate at the point-to-point connection serial maximum	115.2 kbit/s	38.4 kbit/s
Transmission time for user data		
• for write access per byte typical	0.6 ms	40 ms
• for read access per byte typical	0.6 ms	40 ms
Interfaces		
Standard for interfaces for communication	RS422	IO-Link
Type of electrical connection	M12, 8-pin	M12, 4-pin
Mechanical data		
Material	Brass, nickel-plated / PBT	Brass, nickel-plated / PBT
Color	silver/pastel turquoise	silver/pastel turquoise
Tightening torque of the screw for securing the equipment maximum	40 Nm	40 Nm
Mounting distance relating to metal surfaces recommended minimum	0 mm	0 mm





RFID systems for the HF range

SIMATIC RF200 readers

RF220R

	6GT2821-2AC10	6GT2821-2AC32
Article number	RF220R reader	RF220R reader IO-Link
Product type designation	RF220R reader	RF220R reader IO-Link
Supply voltage, current consumption, power loss		
Supply voltage		
• at DC Rated value	24 V	24 V
• at DC	20.4 ... 28.8 V	20.4 ... 28.8 V
Consumed current at DC at 24 V		
• typical	0.05 A	0.05 A
Permitted ambient conditions		
Ambient temperature		
• during operation	-20 ... +70 °C	-20 ... +70 °C
• during storage	-25 ... +80 °C	-25 ... +80 °C
• during transport	-25 ... +80 °C	-25 ... +80 °C
Protection class IP	IP67	IP67
Shock resistance	EN 60721-3-7, Class 7 M2	EN 60721-3-7, Class 7 M2
Shock acceleration	500 m/s ²	500 m/s ²
Vibrational acceleration	200 m/s ²	200 m/s ²
Design, dimensions and weight		
Height	83 mm	83 mm
Diameter	30 mm	30 mm
Net weight	0.14 kg	0.14 kg
Mounting type	2 x M30 nuts (included in scope of supply)	2 x M30 nuts (included in scope of supply)
Cable length		
• for RS422 interface maximum	1 000 m	
• between master and IO-Link device maximum		20 m
Product properties, functions, components general		
Display version	3-color LED	3-color LED
Product feature silicon-free	Yes	Yes
Standards, specifications, approvals		
Certificate of suitability	Wireless according to R&TTE guidelines EN300 330 and EN 301489, FCC, UL/CSA	Wireless according to R&TTE guidelines EN300 330 and EN 301489, FCC, UL/CSA
MTBF	501 y	501 y
Accessories		
Accessories		IO-Link master, IO-Link connecting cables

Selection and ordering data

	Article No.
SIMATIC RF220R reader (RS422)	6GT2821-2AC10
SIMATIC RF220R reader (IO-Link)	6GT2821-2AC32
Accessories	
Note: All connection options can be found in Chapter 5, "Communication Modules".	
IO-Link master SM 1278 For SIMATIC S7-1200, for 4 readers.	6ES7278-4BD32-0XB0
	
IO-Link master 4SI For SIMATIC ET 200S, for 4 readers.	6ES7138-4GA50-0AB0
	
IO-Link master For SIMATIC ET 200eco PN, for 4 readers.	6ES7148-6JA00-0AB0
	
IO-Link master For ET 200SP, for 4 readers.	6ES7137-6BD00-0BA0
	
IO-Link master For ET 200AL, for 4 readers.	6ES7147-5JD00-0BA0
	

Article No.

IO-Link connecting cables



- between IO-Link master and reader, with M12 plug on the IO-Link master, open end, 4-pole, 5 m
- between IO-Link master and reader, with M12 plug on the IO-Link master, open end, 4-pole, 10 m
- between IO-Link master and reader, with M12 plug at both ends, 4-pole, 5 m
- between IO-Link master and reader, with M12 plug at both ends, 4-pole, 10 m

6GT2891-4LH50**6GT2891-4LN10****6GT2891-4MH50****6GT2891-4MN10**

DVD „RFID-Systems Software & Documentation“

6GT2080-2AA20

Dimensional drawings

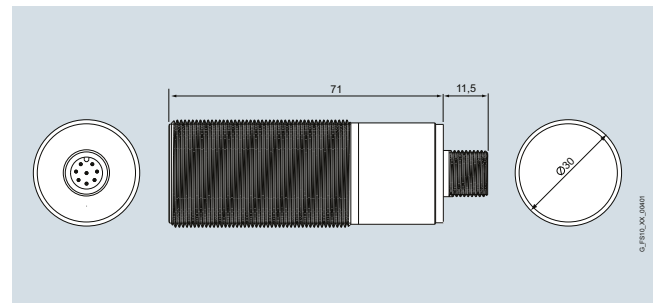

SIMATIC RF220R reader

More information

All current wireless approvals can be found on the Internet at:

<http://www.siemens.com/rfid-approvals>

RFID systems for the HF range

SIMATIC RF200 readers

RF240R

Overview









SIMATIC RF240R is a reader with an integrated antenna. Its extra compact design makes it ideal for use in small assembly lines.

This reader has either

- an RS422 interface with 3964R transmission procedure for connection to RFID communication modules (see Chapter 5),
- or an RS232 interface with ASCII protocol for connection to S7-1200, PC-based systems or third-party controllers,
- or a standardized IO-Link interface for connection to IO-Link Master modules from Siemens or third parties.

Thanks to its high degree of protection and rugged design, the SIMATIC RF240R reader enables problem-free use even under the toughest industrial conditions. Connection is made either with an 8-pin M12 plug-in connector (RS422/RS232 version) or a 4-pin M12 plug-in connector (IO-Link version).

The reader is operated with ISO 15693-compatible transponders.

 CM	 ISO	6GT2821-4AC10
 RS232	 ISO	6GT2821-4AC40
 IO-Link	 ISO	6GT2821-4AC32

Design

Minimum distance from reader to reader	
SIMATIC RF240R	≥ 120 mm

Technical specifications

	6GT2821-4AC10	6GT2821-4AC40	6GT2821-4AC32
Article number	RF240R reader	RF240R reader ASCII	RF240R reader IO-Link
Product type designation	RF240R reader	RF240R reader ASCII	RF240R reader IO-Link
Suitability for operation	ISO 15693 transponders (MDS Dxxx), for connecting to communication modules	ISO 15693 transponders (MDS Dxxx), for connecting to PC- and control systems	ISO 15693 transponders (MDS Dxxx), for connecting to an IO-Link Master
Wireless frequencies			
Operating frequency Rated value	13.56 MHz	13.56 MHz	13.56 MHz
Electrical data			
Range maximum	65 mm; Range is dependent on transponder type: observe http://support.automation.siemens.com/WW/view/en/67384964	65 mm; Range is dependent on transponder type: observe	65 mm; Range is dependent on transponder type: observe
Protocol with radio transmission	ISO 15693, ISO 18000-3	ISO 15693, ISO 18000-3	ISO 15693, ISO 18000-3
Transfer rate with radio transmission maximum	26.5 kbit/s	26.5 kbit/s	26.5 kbit/s
Product feature multitag-capable	No	No	No
Transfer rate at the point-to-point connection serial maximum	115.2 kbit/s	115.2 kbit/s	38.4 kbit/s
Transmission time for user data			
• for write access per byte typical	0.6 ms	1.2 ms	40 ms
• for read access per byte typical	0.6 ms	1.2 ms	40 ms
Interfaces			
Standard for interfaces for communication	RS422	RS232	IO-Link
Type of electrical connection	M12, 8-pin	M12, 8-pin	M12, 4-pin

RFID systems for the HF range

SIMATIC RF200 readers

RF240R

Article number	6GT2821-4AC10	6GT2821-4AC40	6GT2821-4AC32
Product type designation	RF240R reader	RF240R reader ASCII	RF240R reader IO-Link
Mechanical data			
Material	PA6.6	PA6.6	PA6.6
Color	anthracite	anthracite	anthracite
Tightening torque of the screw for securing the equipment maximum	1.5 Nm	1.5 Nm	1.5 Nm
Mounting distance relating to metal surfaces recommended minimum	0 mm	0 mm	0 mm
Supply voltage, current consumption, power loss			
Supply voltage			
• at DC Rated value	24 V	24 V	24 V
• at DC	20.4 ... 28.8 V	20.4 ... 28.8 V	20.4 ... 28.8 V
Consumed current at DC at 24 V			
• typical	0.05 A	0.05 A	0.05 A
Permitted ambient conditions			
Ambient temperature			
• during operation	-20 ... +70 °C	-20 ... +70 °C	-20 ... +70 °C
• during storage	-25 ... +80 °C	-25 ... +80 °C	-25 ... +80 °C
• during transport	-25 ... +80 °C	-25 ... +80 °C	-25 ... +80 °C
Protection class IP	IP67	IP67	IP67
Shock resistance	EN 60721-3-7, Class 7 M2	EN 60721-3-7, Class 7 M2	EN 60721-3-7, Class 7 M2
Shock acceleration	500 m/s ²	500 m/s ²	500 m/s ²
Vibrational acceleration	200 m/s ²	200 m/s ²	200 m/s ²
Design, dimensions and weight			
Width	50 mm	50 mm	50 mm
Height	30 mm	30 mm	30 mm
Depth	50 mm	50 mm	50 mm
Net weight	0.06 kg	0.06 kg	0.06 kg
Mounting type	2 x M5 screws	2 x M5 screws	2 x M5 screws
Cable length			
• with RS232 interface maximum		30 m	
• for RS422 interface maximum	1 000 m		
• between master and IO-Link device maximum			20 m
Product properties, functions, components general			
Display version	3-color LED	3-color LED	3-color LED
Product feature silicon-free	Yes	Yes	Yes
Standards, specifications, approvals			
Certificate of suitability	Wireless according to R&TTE guidelines EN300 330 and EN 301489, FCC, UL/CSA	Wireless according to R&TTE guidelines EN300 330 and EN 301489, FCC, UL/CSA	Wireless according to R&TTE guidelines EN300 330 and EN 301489, FCC, UL/CSA
MTBF	430 y	430 y	430 y
Accessories			
Accessories	Connecting cables	Connecting cables	IO-Link master, IO-Link connecting cables









2

RFID systems for the HF range

SIMATIC RF200 readers

RF240R

Selection and ordering data

	Article No.		Article No.
SIMATIC RF240R reader (RS422)	6GT2821-4AC10	IO-Link master For ET 200AL, for 4 readers.	6ES7147-5JD00-0BA0
SIMATIC RF240R reader (RS232 - ASCII)	6GT2821-4AC40		
SIMATIC RF240R reader (IO-Link)	6GT2821-4AC32	RS232 connecting cable Between reader and PC (RS232), 5 m long, material: PUR, CMG approval.	
Accessories Note: All connection options can be found in Chapter 5, "Communication Modules".		<ul style="list-style-type: none"> • 24 V connection with M12 plug 	6GT2891-4KH50
IO-Link master SM 1278 For SIMATIC S7-1200, for 4 readers.	6ES7278-4BD32-0XB0		
		<ul style="list-style-type: none"> • 24 V connection with open ends 	6GT2891-4KH50-0AX0
IO-Link master 4SI For SIMATIC ET 200S, for 4 readers.	6ES7138-4GA50-0AB0		
		IO-Link connecting cables	
IO-Link master For SIMATIC ET 200eco PN, for 4 readers.	6ES7148-6JA00-0AB0		
		<ul style="list-style-type: none"> • between IO-Link Master and reader, with M12 connector on the IO-Link Master, open end, 4-pin, 5 m 	6GT2891-4LH50
IO-Link master For ET 200SP, for 4 readers.	6ES7137-6BD00-0BA0	<ul style="list-style-type: none"> • between IO-Link Master and reader, with M12 connector on the IO-Link Master, open end, 4-pin, 10 m 	6GT2891-4LN10
		<ul style="list-style-type: none"> • between IO-Link Master and reader, with M12 connector at both ends, 4-pin, 5 m 	6GT2891-4MH50
		<ul style="list-style-type: none"> • between IO-Link Master and reader, with M12 connector at both ends, 4-pin, 10 m 	6GT2891-4MN10
		DVD „RFID-Systems Software & Documentation“	6GT2080-2AA20

Dimensional drawings

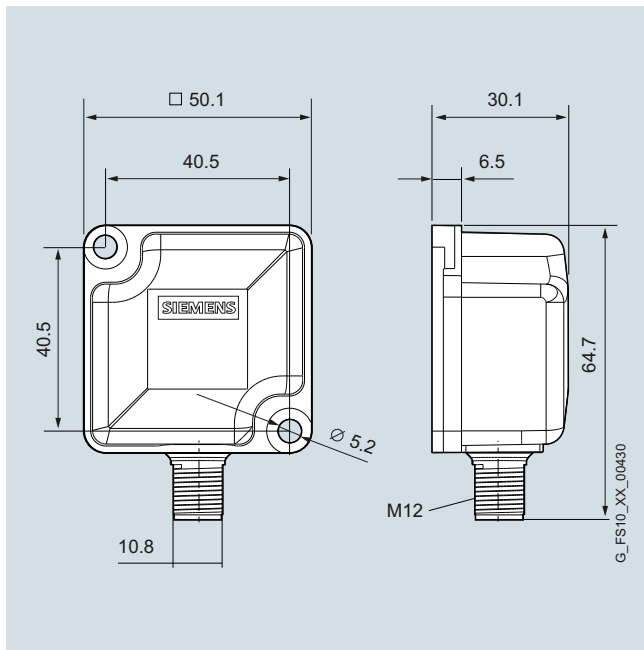

SIMATIC RF240R reader

More information

All current wireless approvals can be found on the Internet at:
<http://www.siemens.com/rfid-approvals>

RFID systems for the HF range

SIMATIC RF250R readers

RF250R

Overview

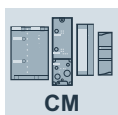

CM



ISO

6GT2821-5AC10



RS232



ISO

6GT2821-5AC40



IO-Link



ISO

6GT2821-5AC32

SIMATIC RF250R is a reader for operation with external antennas. Thanks to the different antenna designs (ANT 3, ANT 3S, ANT 8, ANT 12, ANT 18 and ANT 30), the potential applications in the areas of tool identification and small assembly lines are extremely varied.

This reader has either

- an RS422 interface with 3964R transmission procedure for connection to RFID communication modules (see Chapter 5),
- or an RS232 interface with ASCII protocol for connection to S7-1200, PC-based systems or third-party controllers,
- or a standardized IO-Link interface for connection to IO-Link Master modules from Siemens or third parties.

Thanks to its high degree of protection and rugged design, the SIMATIC RF250R reader enables problem-free use even under the toughest industrial conditions.

Connection is made either with an 8-pin M12 plug-in connector (RS422/RS232 version) or a 4-pin M12 plug-in connector (IO-Link version).

The reader is operated with ISO 15693-compatible transponders.

Connectable antennas

One of each of the following antennas can be operated on a SIMATIC RF250R reader:

- ANT 3, due to its slimline, compact design, this antenna can still be precisely positioned even in cramped conditions. The dimensions are L x W x H (mm): 50 x 28 x 10.
- ANT 3S, same as ANT 3, except suitable exclusively for processing of MDS D117, MDS D127, MDS D421 and MDS D521 transponders. The dimensions are L x W x H (mm): 50 x 28 x 10.
- ANT 8, this cylindrical antenna is mainly intended for the field of tool identification. The extremely small design of the antenna enables extremely accurate positioning, dimensions $\varnothing \times L$ (mm) M8 x 38.
- ANT 12, universal round antenna in M12 design for assembly lines with extremely small workpiece holders, dimensions $\varnothing \times L$ (mm) M12 x 40.
- ANT 18, universal round antenna in M18 design for assembly lines with small workpiece holders, dimensions $\varnothing \times L$ (mm) M18 x 55.
- ANT 30, universal round antenna for assembly lines with small workpiece holders, dimensions $\varnothing \times L$ (mm) M30 x 58.

Design

Connectable antennas	ANT 3	ANT 3S	ANT 8	ANT 12	ANT 18	ANT 30
See page	2/132	2/133	2/134	2/136	2/137	2/138
Inductive interface to the transponder	13.56 MHz					
Range, max.	50 mm	17 mm	4 mm	17 mm	37 mm	60 mm

Minimum distance between antennas

RF250R with antenna	ANT 3	ANT 3S	ANT 8	ANT 12	ANT 18	ANT 30
Minimum distance (mm) from antenna to antenna (D)						
• ANT 3	60	-	-	-	-	-
• ANT 3S	-	80	-	-	-	-
• ANT 8	-	-	60	-	-	-
• ANT 12	-	-	-	80	-	-
• ANT 18	-	-	-	-	125	-
• ANT 30	-	-	-	-	-	200

Technical specifications

	6GT2821-5AC10	6GT2821-5AC40	6GT2821-5AC32
Article number			
Product type designation	RF250R reader	RF250R reader ASCII	RF250R reader IO-Link
Suitability for operation	ISO 15693 transponders (MDS Dxxx), for connecting to communication modules	ISO 15693 transponders (MDS Dxxx), for connecting to PC- and control systems	ISO 15693 transponders (MDS Dxxx), for connecting to an IO-Link Master
Wireless frequencies			
Operating frequency Rated value	13.56 MHz	13.56 MHz	13.56 MHz
Electrical data			
Range maximum	60 mm; Range is dependent on transponder type: observe http://support.automation.siemens.com/WW/view/en/67384964	60 mm; Range is dependent on transponder type: observe	60 mm; Range is dependent on transponder type: observe
Protocol with radio transmission	ISO 15693, ISO 18000-3	ISO 15693, ISO 18000-3	ISO 15693, ISO 18000-3
Transfer rate with radio transmission maximum	26.5 kbit/s	26.5 kbit/s	26.5 kbit/s
Product feature multitag-capable	No	No	No
Transfer rate at the point-to-point connection serial maximum	115.2 kbit/s	115.2 kbit/s	38.4 kbit/s
Transmission time for user data			
• for write access per byte typical	0.6 ms	1.2 ms	40 ms
• for read access per byte typical	0.6 ms	1.2 ms	40 ms
Interfaces			
Number of external antennas	1	1	1
Standard for interfaces for communication	RS422	RS232	IO-Link
Type of electrical connection			
• for external antenna(s)	M8, 4-pin	M8, 4-pin	M8, 4-pin
• for communications interface	M12, 8-pin	M12, 8-pin	M12, 4-pin
Mechanical data			
Material	PA6.6	PA6.6	PA6.6
Color	anthracite	anthracite	anthracite
Tightening torque of the screw for securing the equipment maximum	1.5 Nm	1.5 Nm	1.5 Nm
Mounting distance relating to metal surfaces recommended minimum	0 mm	0 mm	0 mm
Supply voltage, current consumption, power loss			
Supply voltage			
• at DC Rated value	24 V	24 V	24 V
• at DC	20.4 ... 28.8 V	20.4 ... 28.8 V	20.4 ... 28.8 V
Consumed current at DC at 24 V			
• typical	0.05 A	0.05 A	0.05 A
Permitted ambient conditions			
Ambient temperature			
• during operation	-20 ... +70 °C	-20 ... +70 °C	-20 ... +70 °C
• during storage	-25 ... +80 °C	-25 ... +80 °C	-25 ... +80 °C
• during transport	-25 ... +80 °C	-25 ... +80 °C	-25 ... +80 °C
Protection class IP	IP65	IP65	IP65
Shock resistance	EN 60721-3-7, Class 7 M2	EN 60721-3-7, Class 7 M2	EN 60721-3-7, Class 7 M2
Shock acceleration	500 m/s ²	500 m/s ²	500 m/s ²
Vibrational acceleration	200 m/s ²	200 m/s ²	200 m/s ²

RFID systems for the HF range

SIMATIC RF200 readers





RF250R

Article number	6GT2821-5AC10	6GT2821-5AC40	6GT2821-5AC32
Product type designation	RF250R reader	RF250R reader ASCII	RF250R reader IO-Link
Design, dimensions and weight			
Width	50 mm	50 mm	50 mm
Height	30 mm	30 mm	30 mm
Depth	50 mm	50 mm	50 mm
Net weight	0.06 kg	0.06 kg	0.06 kg
Mounting type	2 x M5 screws	2 x M5 screws	2 x M5 screws
Cable length			
• with RS232 interface maximum		30 m	
• for RS422 interface maximum	1 000 m		
• between master and IO-Link device maximum			20 m
Product properties, functions, components general			
Display version	3-color LED	3-color LED	3-color LED
Product feature silicon-free	Yes	Yes	Yes
Standards, specifications, approvals			
Certificate of suitability	Wireless according to R&TTE guidelines EN300 330 and EN 301489, FCC, UL/CSA	Wireless according to R&TTE guidelines EN300 330 and EN 301489, FCC, UL/CSA	Wireless according to R&TTE guidelines EN300 330 and EN 301489, FCC, UL/CSA
MTBF	430 y	430 y	430 y
Accessories			
Accessories	Various antennas are available, connecting cables	Various antennas are available, connecting cables	Various antennas are available, IO-Link master, IO-Link connecting cables

2

Selection and ordering data

	Article No.
SIMATIC RF250R reader (RS422 - 3964R) Without antenna, for connecting external antennas.	6GT2821-5AC10
SIMATIC RF250R reader (RS232 - ASCII) Without antenna, for connecting external antennas.	6GT2821-5AC40
SIMATIC RF250R reader (IO-Link) Without antenna, for connecting external antennas.	6GT2821-5AC32
Accessories	
Note: All connection options can be found in Chapter 5, "Communication Modules".	
Antennas	
External antenna ANT 3 For RF250R reader, with antenna connecting cable (3 m, double ended (plug M8 straight / M8 angled)). See page 2/132.	6GT2398-1CD40-0AX0
External antenna ANT 3S For RF350R reader, with antenna connecting cable (3 m, double ended (plug M8 straight / M8 angled)). See page 2/133.	6GT2398-1CD60-0AX0
External antenna ANT 8 For RF250R reader, with antenna connecting cable (3 m), double ended (plug M8 straight / M8 angled). See page 2/134.	6GT2398-1CF10
External antenna ANT 12 For RF250R readers, with antenna connecting cable. See page 2/136.	6GT2398-1CC00
External antenna ANT 18 For RF250R readers, with antenna connecting cable. See page 2/137.	6GT2398-1CA00
External antenna ANT 30 For RF250R readers, with antenna connecting cable. See page 2/138.	6GT2398-1CD00

	Article No.
IO-Link master	
IO-Link master SM 1278 For SIMATIC S7-1200, for 4 readers.	6ES7278-4BD32-0XB0
	
IO-Link master 4SI For SIMATIC ET 200S, for 4 readers.	
	
IO-Link master For SIMATIC ET 200eco PN, for 4 readers.	
	
IO-Link master For ET 200SP, for 4 readers.	
	
IO-Link master For ET 200AL, for 4 readers.	
	

RFID systems for the HF range

SIMATIC RF200 readers

RF250R

Article No.

Connecting cables

RS232 connecting cable

Between reader and PC (RS232), 5 m, material: PUR, CMG approval. CMG-Zulassung.

- 24 V connection with M12 plug



6GT2891-4KH50

- 24 V connection with open ends



6GT2891-4KH50-0AX0

IO-Link connecting cables



- between IO-Link Master and reader, with M12 connector on the IO-Link Master, open end, 4-pin, 5 m

6GT2891-4LH50

- between IO-Link Master and reader, with M12 connector on the IO-Link Master, open end, 4-pin, 10 m

6GT2891-4LN10

- between IO-Link Master and reader, with M12 connector at both ends, 4-pin, 5 m

6GT2891-4MH50

- between IO-Link Master and reader, with M12 connector at both ends, 4-pin, 10 m

6GT2891-4MN10

DVD "RFID-Systems Software & Documentation"

6GT2080-2AA20

Dimensional drawings

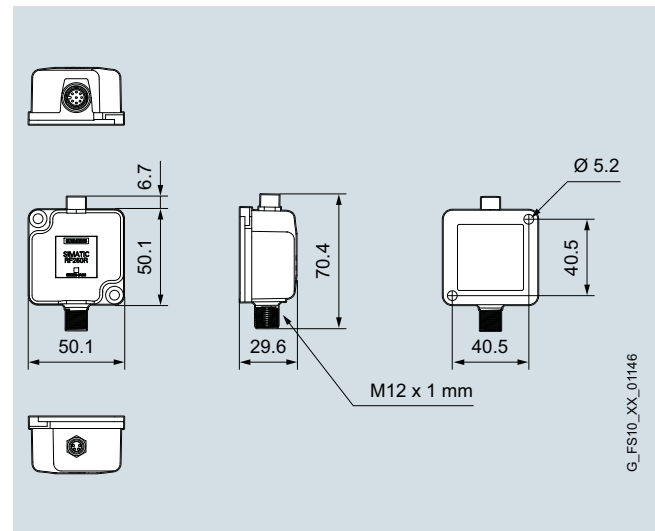

SIMATIC RF250R reader

More information

All current wireless approvals can be found on the Internet at:

<http://www.siemens.com/rfid-approvals>

Overview



SIMATIC RF260R is a reader with an integrated antenna. Its compact design makes it ideal for use in assembly lines.





This reader has either:

- an RS422 interface with 3964R transmission procedure for connection to the RFID communication modules (see Chapter 5),
- an RS232 interface with ASCII protocol for connection to S7-1200, PC-based systems or third-party controllers,
- or a standardized IO-Link interface for connection to IO-Link master modules from Siemens or third parties.

Thanks to its high degree of protection and rugged design, the SIMATIC RF260R reader enables problem-free use even under the toughest industrial conditions.

Connection is by means of either an 8-pin M12 plug-in connector (RS422/RS232 version) or a 4-pin M12 plug-in connector (IO-Link version).

The reader is operated with ISO 15693-compatible transponders.

 CM	 ISO	6GT2821-6AC10
 RS232	 ISO	6GT2821-6AC40
 IO-Link	 ISO	6GT2821-6AC32

Design

Minimum distance from reader to reader	
SIMATIC RF260R	≥ 150 mm

Technical specifications

	6GT2821-6AC10	6GT2821-6AC40	6GT2821-6AC32
Article number	6GT2821-6AC10	6GT2821-6AC40	6GT2821-6AC32
Product type designation	RF260R reader	RF260R ASCII reader	RF260R IO-Link reader
Suitability for operation	ISO 15693 transponders (MDS Dxxx), for connecting to communication modules	ISO 15693 transponders (MDS Dxxx), for connecting to PC- and control systems	ISO 15693 transponders (MDS Dxxx), for connecting to an IO-Link Master systems
Wireless frequencies			
Operating frequency Rated value	13.56 MHz	13.56 MHz	13.56 MHz
Electrical data			
Range maximum	135 mm; Range is dependent on transponder type: observe http://support.automation.siemens.com/WW/view/en/67384964		
Protocol with radio transmission	ISO 15693, ISO 18000-3	ISO 15693, ISO 18000-3	ISO 15693, ISO 18000-3
Transfer rate with radio transmission maximum	26.5 kbit/s	26.5 kbit/s	26.5 kbit/s
Product feature multitag-capable	No	No	No
Transfer rate at the point-to-point connection serial maximum	115.2 kbit/s	115.2 kbit/s	38.4 kbit/s
Transmission time for user data			
• for write access per byte typical	0.6 ms	1.2 ms	40 ms
• for read access per byte typical	0.6 ms	1.2 ms	40 ms
Interfaces			
Standard for interfaces for communication	RS422	RS232	IO-Link
Type of electrical connection	M12, 8-pin	M12, 8-pin	M12, 4-pin





RFID systems for the HF range



SIMATIC RF200 readers

RF260R

Article number	6GT2821-6AC10	6GT2821-6AC40	6GT2821-6AC32
Product type designation	RF260R reader	RF260R ASCII reader	RF260R IO-Link reader
Mechanical data			
Material	PA6.6	PA6.6	PA6.6
Color	anthracite	anthracite	anthracite
Tightening torque of the screw for securing the equipment maximum	1.5 Nm	1.5 Nm	1.5 Nm
Mounting distance relating to metal surfaces recommended minimum	0 mm	0 mm	0 mm
Supply voltage, current consumption, power loss			
Supply voltage			
• at DC Rated value	24 V	24 V	24 V
• at DC	20.4 ... 28.8 V	20.4 ... 28.8 V	20.4 ... 28.8 V
Consumed current at DC at 24 V			
• typical	0.05 A	0.05 A	0.05 A
Permitted ambient conditions			
Ambient temperature			
• during operation	-20 ... +70 °C	-20 ... +70 °C	-20 ... +70 °C
• during storage	-25 ... +80 °C	-25 ... +80 °C	-25 ... +80 °C
• during transport	-25 ... +80 °C	-25 ... +80 °C	-25 ... +80 °C
Protection class IP	IP67	IP67	IP67
Shock resistance	EN 60721-3-7, Class 7 M2	EN 60721-3-7, Class 7 M2	EN 60721-3-7, Class 7 M2
Shock acceleration	500 m/s ²	500 m/s ²	500 m/s ²
Vibrational acceleration	200 m/s ²	200 m/s ²	200 m/s ²
Design, dimensions and weight			
Width	75 mm	75 mm	75 mm
Height	41 mm	41 mm	41 mm
Depth	75 mm	75 mm	75 mm
Net weight	0.2 kg	0.2 kg	0.2 kg
Mounting type	2 x M5 screws	2 x M5 screws	2 x M5 screws
Cable length			
• with RS232 interface maximum		30 m	
• for RS422 interface maximum	1 000 m		
• between master and IO-Link device maximum			20 m
Product properties, functions, components general			
Display version	3-color LED	3-color LED	3-color LED
Product feature silicon-free	Yes	Yes	Yes
Standards, specifications, approvals			
Certificate of suitability	Wireless according to R&TTE guidelines EN300 330 and EN 301489, FCC, UL/CSA	Wireless according to R&TTE guidelines EN300 330 and EN 301489, FCC, UL/CSA	Wireless according to R&TTE guidelines EN300 330 and EN 301489, FCC, UL/CSA
MTBF	480 y	430 y	480 y
Accessories			
Accessories	Connecting cables	Connecting cables	IO-Link master, IO-Link connecting cables

Selection and ordering data

	Article No.
SIMATIC RF260R reader (RS422)	6GT2821-6AC10
SIMATIC RF260R reader (RS232 - ASCII)	6GT2821-6AC40
SIMATIC RF260R reader (IO-Link)	6GT2821-6AC32
Accessories	
Note: All connection options can be found in section 5, "Communication Modules".	
IO-Link master	
IO-Link master SM 1278 For SIMATIC S7-1200, for 4 readers.	6ES7278-4BD32-0XB0
	
IO-Link master 4SI For SIMATIC ET 200S, for 4 readers	6ES7138-4GA50-0AB0
	
IO-Link master For SIMATIC ET 200eco PN, for 4 readers	6ES7148-6JA00-0AB0
	
IO-Link master For ET 200SP, for 4 readers.	6ES7137-6BD00-0BA0
	
IO-Link master For ET 200AL, for 4 readers.	6ES7147-5JD00-0BA0
	

	Article No.
Connecting cables	
RS232 connecting cable	
Between reader and PC (RS232), 5 m, material: PUR, CMG approval. CMG-Zulassung.	
<ul style="list-style-type: none"> • 24 V connection with M12 plug 	6GT2891-4KH50
<ul style="list-style-type: none"> • 24 V connection with open ends 	6GT2891-4KH50-0AX0
IO-Link connecting cables	
	6GT2891-4LH50
<ul style="list-style-type: none"> • between IO-Link Master and reader, with M12 connector on the IO-Link Master, open end, 4-pin, 5 m 	6GT2891-4LN10
<ul style="list-style-type: none"> • between IO-Link Master and reader, with M12 connector on the IO-Link Master, open end, 4-pin, 10 m 	6GT2891-4MH50
<ul style="list-style-type: none"> • between IO-Link Master and reader, with M12 connector at both ends, 4-pin, 5 m 	6GT2891-4MN10
DVD „RFID-Systems Software & Documentation“	6GT2080-2AA20

RFID systems for the HF range

SIMATIC RF200 readers

RF260R

Dimensional drawings

More information

All current wireless approvals can be found on the Internet at:

<http://www.siemens.com/rfid-approvals>

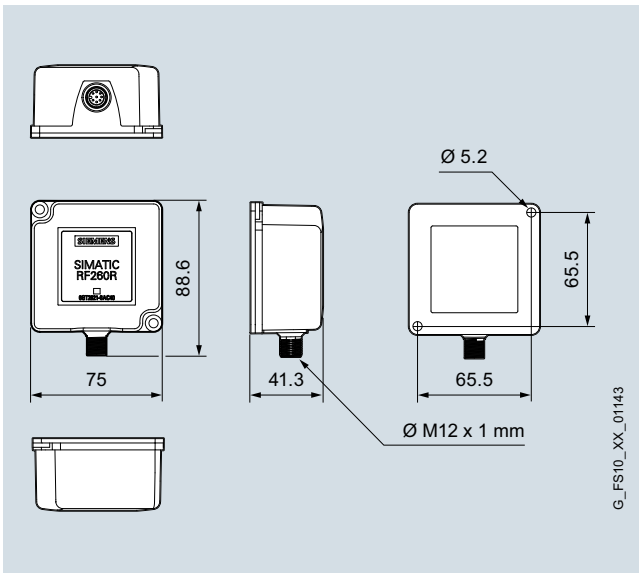

SIMATIC RF260R reader

Overview



The SIMATIC RF290R reader is a compact long-range reader for the upper performance range and ranges of up to 60 cm. Intended for operation with external antennas ANT D1, ANT D5, ANT D6 and ANT D10. The application range for RF290R lies in the area of production control and intralogistics through to gate applications in which longer ranges for HF-RFID are required.

The reader is equipped with a combined RS422/RS232 interface, which is switched over when the corresponding connecting cable is used.

In RS422 mode, the reader can be connected to SIMATIC S7, PROFIBUS, PROFINET or Ethernet TCP/IP via the communication modules (see Chapter 5). Please note that due to the current consumption of the reader on the ASM 456 and RF160C, only one RF290R can be connected.

In the RS232 mode, the reader is suitable for integration into PC-based control systems. Trigger and alarm signals can be connected via digital inputs/outputs.

Furthermore, bulk detection of several hundred transponders is possible.

The antenna switch or the multiplexer enables several individual antennas or portal solutions to be implemented with only one RF290R. The RF260X antenna multiplexer supports the connection of up to 6 antennas to one reader and operates in quasi-parallel mode.

Connectable antennas

One of each of the following antennas can be operated on a SIMATIC RF290R:

- ANT D1
Dimensions L x W x H (mm): 75 x 75 x 20.
- ANT D5
Dimensions L x W x H (mm): 380 x 380 x 110.
- ANT D6
Dimensions L x W x H (mm): 580 x 480 x 110.
- ANT D10
Dimensions L x W x H (mm): 1150 x 365 x 115.

ANT D1

The ANT D1 is a universal antenna for the production and logistics areas that can also be used in dynamic applications. The high degree of protection (IP67) means the antenna can also be used under harsh industrial conditions.

ANT D5

Universal antenna for warehouse, logistics and distribution applications. The high degree of protection (IP65) enables the antenna to be used under harsh industrial conditions.

ANT D6

Antenna in the upper performance range, designed especially for warehouse, logistics and distribution applications. It can be used wherever high speeds are required together with a large write/read distance.

ANT D10

The ANT D10 is suitable for use in warehouses, logistics and distribution. An antenna with this geometry is required in the clothing industry and laundries in particular.

Design

Connectable antennas	ANT D1	ANT D5	ANT D6	ANT D10
See page	2/139	2/141	2/143	2/145
Inductive interface to the transponder	13.56 MHz			
Range	250 mm	480 mm	650 mm	480 mm

SIMATIC RF290R with antenna	ANT D1	ANT D5	ANT D6	ANT D10
Minimum distance (m) from antenna to antenna (D)				
• ANT D1	0,5	-	-	-
• ANT D5	-	2	-	-
• ANT D6	-	-	2	-
• ANT D10	-	-	-	2

RFID systems for the HF range

SIMATIC RF200 readers





RF290R

Technical specifications

Article number	6GT2821-0AC12
Product type designation	RF290R reader
Suitability for operation	ISO 15693 transponders (MDS Dxxx), for connecting to communication modules and PC systems
Wireless frequencies	
Operating frequency Rated value	13.56 MHz
Electrical data	
Range maximum	650 mm; Range adjustable in reader via transmission power, range is dependent on transponder type: observe
http://support.automation.siemens.com/WWW/view/en/67384964	
Protocol with radio transmission	ISO 15693, ISO 18000-3
Transfer rate with radio transmission maximum	26.5 kbit/s
Product feature multitag-capable	Yes
Transfer rate at the point-to-point connection serial maximum	115.2 kbit/s
Transmission time for user data	
• for write access per byte typical	0.6 ms
• for read access per byte typical	0.6 ms
Interfaces	
Number of external antennas	1
Standard for interfaces for communication	RS422/RS232
Type of electrical connection	M12, 8-pin
• for external antenna(s)	TNC
• for supply voltage	M12, 8-pin
• for communications interface	M12, 8-pin
• at the digital inputs/outputs	M12, 4-pin, female connector
Number of digital inputs	1
Number of digital outputs	1
Mechanical data	
Material	aluminum
Color	silver/anthracite
Tightening torque of the screw for securing the equipment maximum	1.5 Nm
Mounting distance relating to metal surfaces recommended minimum	0 mm
Supply voltage, current consumption, power loss	
Supply voltage	
• at DC Rated value	24 V
• at DC	21.6 ... 26.4 V
Consumed current at DC at 24 V	
• typical	0.4 A
• maximum	0.5 A
Permitted ambient conditions	
Ambient temperature	
• during operation	-20 ... +55 °C
• during storage	-25 ... +85 °C
• during transport	-25 ... +85 °C
Protection class IP	IP65
Shock resistance	EN 60721-3-7 Class 7 M2
Shock acceleration	300 m/s ²
Vibrational acceleration	20 m/s ²

Article number	6GT2821-0AC12
Product type designation	RF290R reader
Design, dimensions and weight	
Width	200 mm
Height	80 mm
Depth	140 mm
Net weight	1.8 kg
Mounting type	4 x M6 screws
Cable length	
• of antenna cable minimum	3.3 m
• of antenna cable maximum	25 m
• with RS232 interface maximum	30 m
• for RS422 interface maximum	1 000 m
Product properties, functions, components general	
Display version	4 LEDs
Standards, specifications, approvals	
Certificate of suitability	CE, FCC, IC (Canada)
MTBF	18 y
Accessories	
Accessories	Various antennas are available, antenna combiners, antenna multiplexer, mounting set for top-hat rail mounting

Selection and ordering data

	Article No.
SIMATIC RF290R reader Without antenna	6GT2821-0AC12
Antennas for SIMATIC RF290R reader Including antenna cable	
• Antenna ANT D1	6GT2698-5AC00
• Antenna ANT D5	6GT2698-5AA10
• Antenna ANT D6	6GT2698-5AB00
• Antenna ANT D10 Cover included in scope of delivery.	6GT2698-5AF00
Accessories Note: All connection options can be found in Chapter 5, "Communication Modules".	
Antenna switch For connecting several antennas (ANT D5, ANT D6 or ANT D10) to one reader.	6GT2690-0AC00
	
SIMATIC RF260X antenna multiplexer Antenna multiplexer for RF290R reader when connected via RS232; 6 x antenna outputs (for ANT D5, ANT D6 and ANT D10); IP65; 240 mm x 150 mm x 70 mm; including antenna connecting cable, cable length 0.4 m.	6GT2894-0EA00
	
Covering hood for ANT D6 Serves as protection against contact.	6GT2690-0AD00
RS232 connecting cable Between reader and PC (RS232), 5 m long, material: PUR, CMG approval.	
• 24 V connection with M12 plug	6GT2891-4KH50
	
• 24 V connection with open ends	6GT2891-4KH50-0AX0
	

Article No.

Accessories for antenna switch and antenna multiplexer

Antenna connecting cable

Between antenna and reader or antenna switch/multiplexer, PVC material.

- Length 3.3 m
- Length 10 m

6GT2691-0CH33**6GT2691-0CN10**

Extension cable

For 6GT2691-0CH33, PVC material. Length 7.2 m.

6GT2691-0DH72

Standard rail mounting

6GK5798-8ML00-0AB3

DVD „RFID Systems Software & Documentation“

6GT2080-2AA20

Dimensional drawings

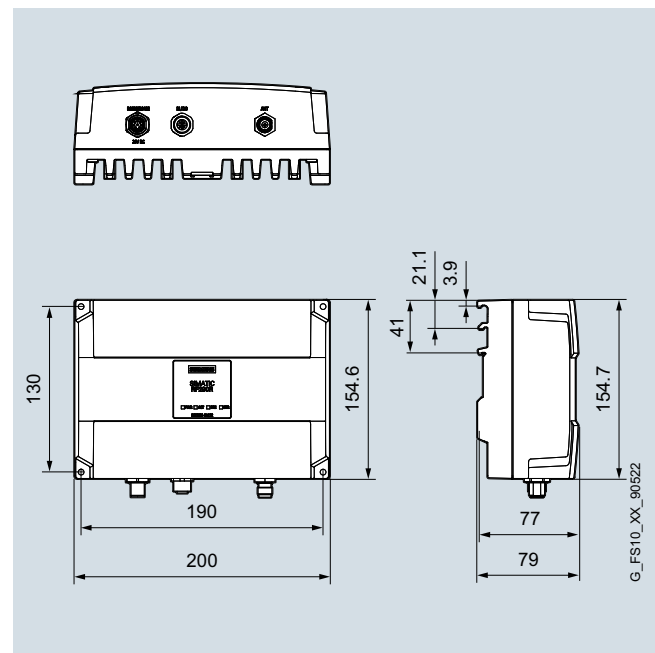

SIMATIC RF290R reader

More information

All current wireless approvals can be found on the Internet at:

<http://www.siemens.com/rfid-approvals>

RFID systems for the HF range

SIMATIC RF300

Introduction

Overview



The RFID system SIMATIC RF300 is particularly suitable for use in industrial production in the areas of production control, assembly lines and conveyors.

SIMATIC RF300 is used to implement identification tasks with medium to high performance in the HF range (13.56 MHz).

Depending on the performance of the identification system, two versions of the system are available:

- Medium performance: System configuration with SIMATIC RF300 readers in ISO 15963 mode and low-cost MOBY D transponders.
- High performance: System configuration with SIMATIC RF300 readers in RF300 mode and SIMATIC RF300 transponders.

The SIMATIC RF300 identification system offers the following features:

- 13.56 MHz operating frequency
- For operating with ISO 15693 mode or RF300 mode
- Passive (without battery), maintenance-free transponder (MDS Dxxx and RF3xxT) with memory up to 64 KB
- Rugged, compact components with IP67 / IP68 degree of protection
- Very high immunity to noise
- Extensive diagnostic functions
- Extremely fast data transmission
- Easy integration into SIMATIC, PROFIBUS, PROFINET and TCP/IP.

Benefits

get Designed for Industry

- Rugged, compact components with high degree of protection (up to IP68).
- Data communication that is highly resistant to interference with a high degree of data security.
- Maintenance-free data carriers with up to 64 KB.
- Extremely high-speed data transmission between reader and transponder (up to 7.8 KB/s).
- Flexible and economic solutions thanks to the complete and scalable portfolio for the field of industrial identification.
- Simplified engineering, commissioning, diagnostics and maintenance through seamless integration into Totally Integrated Automation (TIA):
 - Integrated bus connection to an automation system, such as SIMATIC, SIMOTION or SINUMERIK via communication modules with PROFIBUS and PROFINET.
 - Simple S7 software integration via ready-to-use function blocks.
 - Extensive status and diagnostic functions.
- High investment security thanks to:
 - Open standard in accordance with ISO standard 15693.
 - Software compatibility between the RFID systems of Siemens.
 - Standardized communication interfaces.
- Openness through connection possibilities to various bus systems from different manufacturers and PC environments via communication modules.
- Worldwide service and support.

Application

The RFID system SIMATIC RF300 is used primarily for contact-free identification of containers, pallets and workpiece holders in a closed production cycle. This means that the data carriers (transponders, tags) remain in the production chain and are not shipped out with the products. Thanks to the compact enclosure dimensions of the transponders as well as of the read/write devices, SIMATIC RF300 is particularly suitable for (small) assembly lines where space is at a premium.

The main application areas of SIMATIC RF300 are:

- Assembly and handling systems, assembly lines (identification of workpiece carriers)
- Production logistics (material flow control, identification of containers and other vessels)
- Parts identification (e.g. transponder is attached to product or pallet)
- Conveyor systems (e.g. overhead monorail conveyors)

Design

The high IP68 degree of protection of the SIMATIC RF300 reader enables it to be used in harsh industrial environments.

The SIMATIC RF310R, RF340R and RF380R devices have an integrated antenna. The SIMATIC RF350R reader is operated with an external antenna.

Each SIMATIC RF300 reader has a multicolor LED which locally indicates the function and status of the reader as well as of the transponder.

The interface to the automation level can be implemented by means of communication modules. For quick and easy cabling, pre-assembled cables with M12 plug-in connectors are available in various lengths.

All readers can be operated either according to the RFID standard ISO 15693, or in high-performance RF300 mode.

Depending on the mode of the reader, a comprehensive range of transponders is available for a wide variety of requirements.

For use in accordance with the ISO 15693 standard there are various versions available, e.g. low-cost SmartLabels for simple identification tasks, rugged credit card formats or screw-fit transponders that can be automatically attached by robots.

Additional transponders are available for selection for the high-performance RF300 mode, e.g. particularly heat-resistant transponders for temperatures up to +220 °C, or particularly compact rectangular designs for use on small workpiece holders.

The transponders are attached to the object to be identified, e.g. by means of screws, adhesive or pre-assembled spacer.

Function

All of the SIMATIC RF300 readers are suitable for reliable reading and writing tasks in the HF range of 13.56 MHz. In the ISO 15693 operating mode, identification tasks in the medium-performance range are possible.

The RF300 mode permits high-performance operation with a high-speed data transmission of up to 7.8 kbytes/s and is therefore one of the fastest RFID systems in the HF range.

Connection of readers to the automation level (e.g. SIMATIC S7) via standard fieldbuses (e.g. PROFIBUS or PROFINET) is by means of communication modules to which the readers can be connected via an RS422 interface.

User-friendly function blocks are available for the S7 programming.

In the event of an error, the S7 application receives a detailed error message from the communication module via the function block.

In addition, there is the option of the SIMATIC RF380R readers with an RS232 interface for the connection to the PC or to SIMATIC S7-1200.

The SIMATIC RF380R, RF382R and RF310R readers are available as scan mode variants (read only) for identification tasks without special command control. In these variants, the reader reads each detected transponder (UID or user data) automatically and outputs this data via the serial interface to be received by a PC, for example.

Extended diagnostics functions in RF300 mode, such as the field strength measured variable or the signature error counter, enable the HF field or the quality of the air interface to be measured.

Integration

A wide range of communication modules, function blocks, as well as high-performance drivers and function libraries permits easy and quick integration into the application.

And best of all: SIMATIC RF300 is part of Totally Integrated Automation (TIA) and can be integrated easily and cost-effectively into the SIMATIC world.

For more details on the connection possibilities, see Chapter 5 "Communication Modules".

SIMATIC Ident Configuration Guide

Here is a compact configuration tool for setting up RFID systems:

<http://support.automation.siemens.com/WWW/view/en/67384964>

Technical specifications

RFID system	SIMATIC RF300
Transmission frequency	13.56 MHz
Maximum range	210 mm
Protocol (air interface)	<ul style="list-style-type: none"> • ISO 15693 • ISO 18000-3 • RF300 (proprietary)
Approvals ¹⁾	<ul style="list-style-type: none"> • EN 300330, 301489, CE • FCC Part 15 • UL/CSA • ATEX
Memory capacity	Max. 64 KB
Data transmission rate reader – transponder	
<ul style="list-style-type: none"> • Read • Write 	Max. 7.8 kbyte/s Max. 7.8 kbyte/s
Multitag/Bulk capability	No
Special features	<ul style="list-style-type: none"> • High data transfer rate • Extended diagnostic possibilities • High memory capacity







¹⁾ All current wireless approvals can be found on the Internet at: <http://www.siemens.com/rfid-approvals>

RFID systems for the HF range

SIMATIC RF300 readers

Introduction

Overview

Readers	Features	Page	Readers	Features	Page
RF310R 	Ideal for use on small assembly lines. The reader has an integrated antenna.	2/105	RF380R 	Ideal for use in assembly lines in which long ranges are required. The reader has an integrated antenna.	2/112
RF340R 	Ideal for use on assembly lines. Reader for connecting external antennas	2/107	RF382R 	Ideal for use in assembly lines in which transponders must be read from the side. Reader with integrated special antenna. Scan mode (read only).	2/115
RF350R 	Ideal for use on assembly lines. Reader for connecting external antennas (ANT 1, 3, 3S, 12, 18, 30).	2/109	RF350M 	Mobile handheld terminal with integrated or external read/write antenna.	2/117

Overview

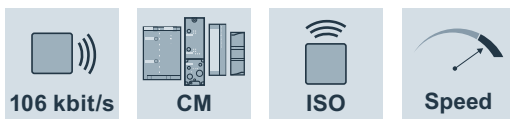

6GT2801-1AB10

Due to its small, compact design, the SIMATIC RF310R reader can be used to considerable advantage in small assembly lines.

This reader is available with an RS422 interface for the RFID communication modules (see Chapter 5).

The SIMATIC RF310R is also available as a scan mode variant (automatic read mode, without command control). This automatic read-only mode does not require a special command control, but supplies the autonomously read transponder data directly to the connected host system.



6GT2801-1AB20-0AX1

Due to the high degree of protection and the use of high-quality materials, the SIMATIC RF310R ensures problem-free operation even under the harshest industrial conditions. It is connected via an 8-pole M12 plug-in connector.

The reader can process the high-speed RF300 transponders and the ISO-15693-compatible transponders (see RFID systems field data table on page 1/10).

Design

Minimum distance from reader to reader

SIMATIC RF310R	≥ 100 mm
----------------	----------

Technical specifications

	6GT2801-1AB10	6GT2801-1AB20-0AX1
Article number	6GT2801-1AB10	6GT2801-1AB20-0AX1
Product type designation	RF310R reader	RF310R reader
Suitability for operation	RF300 and ISO 15693 transponders (MDS Dxxx), for connecting to communication modules	RF300 and ISO 15693 transponders (MDS Dxxx), for serial connection to control systems (Scan Mode)
Wireless frequencies		
Operating frequency Rated value	13.56 MHz	13.56 MHz
Electrical data		
Range maximum	60 mm; Range is dependent on transponder type: observe http://support.automation.siemens.com/WW/view/en/67384964	
Protocol with radio transmission	RF300-specific, ISO 15693, ISO 18000-3	RF300-specific, ISO 15693, ISO 18000-3
Transfer rate with radio transmission maximum	106 kbit/s	106 kbit/s
Product feature multitag-capable	No	No
Transfer rate at the point-to-point connection serial maximum	115.2 kbit/s	115.2 kbit/s
Transmission time for user data		
• for write access per byte typical	0.13 ms	
• for read access per byte typical	0.13 ms	0.13 ms
Interfaces		
Standard for interfaces for communication	RS422	RS422
Type of electrical connection	M12, 8-pin	M12, 8-pin

RFID systems for the HF range

SIMATIC RF300 readers

RF310R

Article number	6GT2801-1AB10	6GT2801-1AB20-0AX1
Product type designation	RF310R reader	RF310R reader
Mechanical data		
Material	PA 12	PA 12
Color	anthracite	anthracite
Mounting distance relating to metal surfaces recommended minimum	0 mm	0 mm
Supply voltage, current consumption, power loss		
Supply voltage		
• at DC Rated value	24 V	24 V
• at DC	20.4 ... 28.8 V	20.4 ... 28.8 V
Consumed current at DC at 24 V		
• typical	0.05 A	0.05 A
Permitted ambient conditions		
Ambient temperature		
• during operation	-25 ... +70 °C	-25 ... +70 °C
• during storage	-40 ... +85 °C	-40 ... +85 °C
• during transport	-40 ... +85 °C	-40 ... +85 °C
Protection class IP	IP67	IP67
Shock resistance	EN 60721-3-7, Class 7 M2	EN 60721-3-7, Class 7 M2
Shock acceleration	500 m/s ²	500 m/s ²
Vibrational acceleration	200 m/s ²	200 m/s ²
Design, dimensions and weight		
Width	55 mm	55 mm
Height	30 mm	30 mm
Depth	75 mm	75 mm
Net weight	0.2 kg	0.2 kg
Mounting type	4 x M5 screws	4 x M5 screws
Cable length		
• for RS422 interface maximum	1 000 m	1 000 m
Product properties, functions, components general		
Display version	3-color LED	3-color LED
Product feature silicon-free	Yes	Yes
Standards, specifications, approvals		
Certificate of suitability	Wireless according to R&TTE guidelines EN 300 330, EN 301489, CE, FCC, UL/CSA	Wireless according to R&TTE guidelines EN 300 330, EN 301489, CE, FCC, UL/CSA
MTBF	154 y	170 y

Selection and ordering data

	Article No.
SIMATIC RF310R reader	
• With RS422 interface (3964R protocol)	6GT2801-1AB10
• as a scan mode variant (RS422)	6GT2801-1AB20-0AX1
Accessories	
Note: All connection options can be found in the chapter 5 "Communication Modules".	
DVD „RFID-Systems Software & Documentation“	6GT2080-2AA20

More information

All current wireless approvals can be found on the Internet at:
<http://www.siemens.com/rfid-approvals>

Dimensional drawings

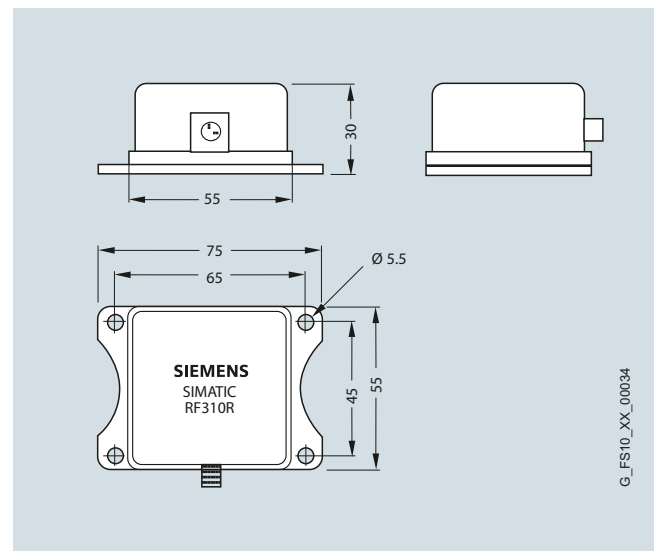

SIMATIC RF310R reader without Scan Mode

Overview



The SIMATIC RF340R is a reader with integrated antenna for the medium performance range and can be used to great advantage in assembly lines thanks to its compact design. This reader is also particularly suitable for dynamic applications, in which the transponder does not stop during the read/write process.

This reader has an RS422 interface with 3964R transmission procedure for connection to RFID communication modules (see Chapter 5).

Thanks to the high degree of protection and the use of high-quality materials, the SIMATIC RF340R ensures problem-free use even under the toughest industrial conditions. It is connected via an 8-pole M12 plug-in connector.

The reader can process the high-speed RF300 transponders and the ISO-15693-compatible transponders (see RFID systems field data table on page 1/10).

Design

Minimum distance from reader to reader	
SIMATIC RF340R	≥ 200 mm

Technical specifications

Article number	6GT2801-2AB10
Product type designation	RF340R reader
Suitability for operation	RF300 and ISO 15693 transponders (MDS Dxxx), for connecting to communication modules

Wireless frequencies	
Operating frequency Rated value	13.56 MHz

Article number	6GT2801-2AB10
Product type designation	RF340R reader
Elektrische Daten	
Range maximum	140 mm; Range is dependent on transponder type: observe
http://support.automation.siemens.com/WWW/view/en/67384964	
Protocol with radio transmission	RF300-specific, ISO 15693, ISO 18000-3
Transfer rate with radio transmission maximum	106 kbit/s
Product feature multitag-capable	No
Transfer rate at the point-to-point connection serial maximum	115.2 kbit/s
Transmission time for user data	
• for write access per byte typical	0.13 ms
• for read access per byte typical	0.13 ms
Interfaces	
Standard for interfaces for communication	RS422
Type of electrical connection	M12, 8-pin
Mechanical data	
Material	PA 12
Color	anthracite
Mounting distance relating to metal surfaces recommended minimum	0 mm
Supply voltage, current consumption, power loss	
Supply voltage	
• at DC Rated value	24 V
• at DC	20.4 ... 28.8 V
Consumed current at DC at 24 V	
• typical	0.1 A
Permitted ambient conditions	
Ambient temperature	
• during operation	-25 ... +70 °C
• during storage	-40 ... +85 °C
• during transport	-40 ... +85 °C
Protection class IP	IP67
Shock resistance	EN 60721-3-7, Class 7 M2
Shock acceleration	500 m/s ²
Vibrational acceleration	200 m/s ²
Design, dimensions and weight	
Width	75 mm
Height	41 mm
Depth	75 mm
Net weight	0.25 kg
Mounting type	2 x M5 screws
Cable length	
• for RS422 interface maximum	1 000 m
Product properties, functions, components general	
Display version	3-color LED
Product feature silicon-free	Yes
Standards, specifications, approvals	
Certificate of suitability	Wireless according to R&TTE guidelines EN 300 330, EN 301489, CE, FCC, UL/CSA, Ex: II 3G Ex nA nC IIB T5, II 3D Ex tD A22 IP6x T80°C
MTBF	140 y

RFID systems for the HF range

SIMATIC RF300 readers

RF340R

Selection and ordering data

	Article No.
SIMATIC RF340R reader	6GT2801-2AB10
Accessories	
Note: All connection options can be found in section 5, "Communication Modules".	
DVD „RFID-Systems Software & Documentation“	6GT2080-2AA20

2

Dimensional drawings

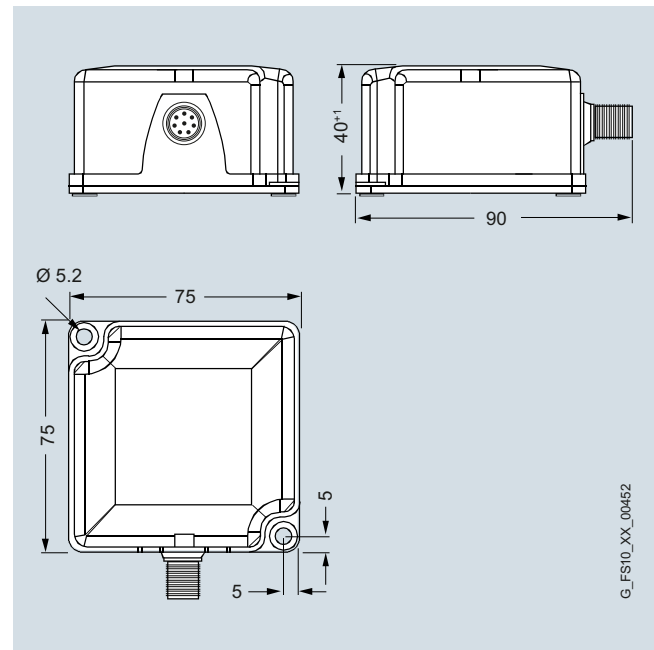

SIMATIC RF340R reader

More information

All current wireless approvals can be found on the Internet at:

<http://www.siemens.com/rfid-approvals>

Overview



SIMATIC RF350R is a universal reader for operation with external antennas. Due to the different, pluggable antenna designs (flat antenna, round antennas), there are many possible applications in the area of industrial production, especially in assembly lines.

This reader has an RS422 interface with 3964R transmission procedure for connection to RFID communication modules (see Chapter 5).

Due to the high degree of protection and the use of high-quality materials, the SIMATIC RF350R ensures problem-free operation even under the harshest industrial conditions. It is connected via an 8-pole M12 plug-in connector.

The reader can process the high-speed RF300 transponders and the ISO-15693-compatible transponders (see RFID systems field data table on page 1/10).

Connectable antennas

One of each of the following antennas can be operated on an RF350R:

- ANT 1, universal flat antenna, also for dynamic applications, dimensions L x W x H (mm): 75 x 75 x 20
- Due to its slimline, compact design, the ANT 3 can still be precisely positioned even in cramped conditions.
Dimensions L x W x H (mm): 50 x 28 x 10
- ANT 3S, same as ANT 3, except suitable exclusively for processing of MDS D117, MDS D127, MDS D421 and MDS D521 transponders. The dimensions are L x W x H (mm): 50 x 28 x 10.
- ANT 12, universal round antenna in M12 design for assembly lines with extremely small workpiece holders.
Dimensions Ø x L (mm): M12 x 40
- ANT 18, universal round antenna in M18 design for assembly lines with small workpiece holders.
Dimensions Ø x L (mm): M18 x 55
- ANT 30, universal round antenna for assembly lines with small workpiece holders.
Dimensions Ø x L (mm): M30 x 58

Design

Connectable antennas	ANT 1	ANT 3	ANT 3S	ANT 12	ANT 18	ANT 30
See page	2/131	2/132	2/133	2/136	2/137	2/138
Inductive interface to the transponder	13.56 MHz					
Range, max	140 mm	45 mm	16 mm	16 mm	35 mm	55 mm

Minimum distance between antennas

RF350R with antenna	ANT 1	ANT 3	ANT 3S	ANT 12	ANT 18	ANT 30
Minimum distance (mm) from antenna to antenna (D)						
• ANT 1	800	-	-	-	-	-
• ANT 3	-	200	-	-	-	-
• ANT 3S	-	-	80	-	-	-
• ANT 12	-	-	-	80	-	-
• ANT 18	-	-	-	-	125	-
• ANT 30	-	-	-	-	-	200

RFID systems for the HF range

SIMATIC RF300 readers

RF350R

Technical specifications

Article number	6GT2801-4AB10
Product type designation	RF350R reader
Suitability for operation	RF300 and ISO 15693 transponders (MDS Dxxx), for connecting to communication modules
Wireless frequencies	
Operating frequency Rated value	13.56 MHz
Electrical data	
Range maximum	140 mm; Range is dependent on transponder type: observe
http://support.automation.siemens.com/WW/view/en/67384964	
Protocol with radio transmission	RF300-specific, ISO 15693, ISO 18000-3
Transfer rate with radio transmission maximum	106 kbit/s
Product feature multitag-capable	No
Transfer rate at the point-to-point connection serial maximum	115.2 kbit/s
Transmission time for user data	
• for write access per byte typical	0.13 ms
• for read access per byte typical	0.13 ms
Interfaces	
Number of external antennas	1
Standard for interfaces for communication	RS422
Type of electrical connection	
• for external antenna(s)	M8, 4-pin
• for communications interface	M12, 8-pin
Mechanical data	
Material	PA 12
Color	anthracite
Mounting distance relating to metal surfaces recommended minimum	0 mm
Supply voltage, current consumption, power loss	
Supply voltage	
• at DC Rated value	24 V
• at DC	20.4 ... 28.8 V
Consumed current at DC at 24 V	
• typical	0.1 A
Permitted ambient conditions	
Ambient temperature	
• during operation	-25 ... +70 °C
• during storage	-40 ... +85 °C
• during transport	-40 ... +85 °C
Protection class IP	IP65
Shock resistance	EN 60721-3-7, Class 7 M2
Shock acceleration	500 m/s ²
Vibrational acceleration	200 m/s ²
Design, dimensions and weight	
Width	75 mm
Height	41 mm
Depth	75 mm
Net weight	0.25 kg
Mounting type	2 x M5 screws
Cable length	
• of antenna cable fixed value	3 m
• for RS422 interface maximum	1 000 m

Article number	6GT2801-4AB10
Product type designation	RF350R reader
Product properties, functions, components general	
Display version	3-color LED
Product feature silicon-free	Yes
Standards, specifications, approvals	
Certificate of suitability	Wireless according to R&TTE guidelines EN 300 330, EN 301489, CE, FCC, UL/CSA, Ex: II 3G Ex nA nC IIB T5, II 3D Ex tD A22 IP6x T80°C
MTBF	140 y
Accessories	Various antennas are available

Selection and ordering data

	Article No.
SIMATIC RF350R reader	6GT2801-4AB10
Without antenna	
Antennas	
External antenna ANT 1	6GT2398-1CB00
For RF350R reader, with antenna connecting cable (3 m, permanently connected to antenna ANT 1). See page 2/131.	
External antenna ANT 3	6GT2398-1CD40-0AX0
For RF350R reader, with antenna connecting cable (3 m, double ended (plug M8 straight / M8 angled)). See page 2/132.	
External antenna ANT 3S	6GT2398-1CD60-0AX0
For RF350R reader, with antenna connecting cable (3 m, double ended (plug M8 straight / M8 angled)). See page 2/133.	
External antenna ANT 12	6GT2398-1CC00
For RF350R readers, with antenna connecting cable. See page 2/136.	
External antenna ANT 18	6GT2398-1CA00
For RF350R readers, with antenna connecting cable. See page 2/137.	
External antenna ANT 30	6GT2398-1CD00
For RF350R readers, with antenna connecting cable. See page 2/138.	
Accessories	
Note: All connection options can be found in the chapter 5 "Communication Modules".	
DVD "RFID-Systems Software & Documentation"	6GT2080-2AA20

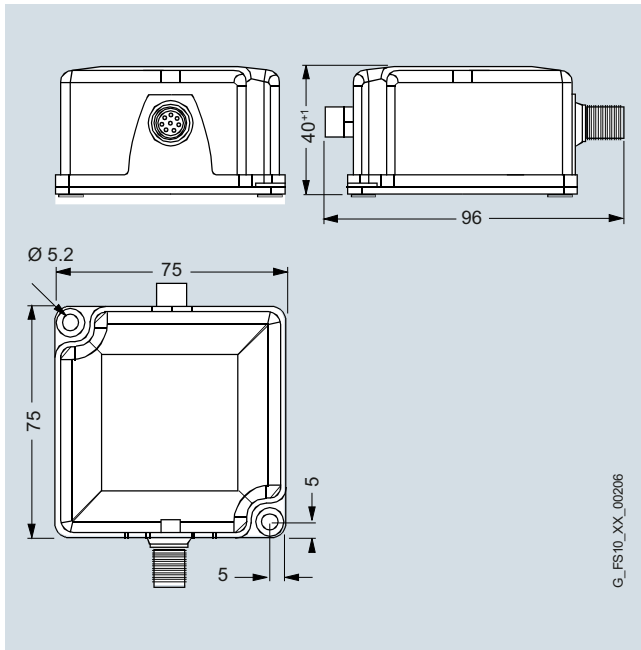
Dimensional drawings

SIMATIC RF350R reader

More information

All current wireless approvals can be found on the Internet at:

<http://www.siemens.com/rfid-approvals>

RFID systems for the HF range

SIMATIC RF300 readers

RF380R

Overview

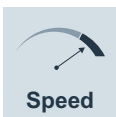
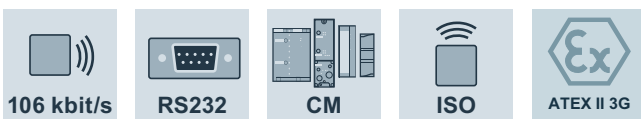

6GT2801-3AB10

SIMATIC RF380R is a reader with an integral antenna for the top-end performance range and its compact construction makes it ideal for use in assembly lines in which long ranges are required (e.g. bodyshop/paintshop in the automotive industry). This reader is also particularly suitable for dynamic applications, in which the transponder does not stop during the read/write process (e.g. baggage conveyors in airports).

This reader has both an RS422 and an RS232 interface with a 3964R transmission procedure for connection to RFID communication modules (see Communication modules) as well as to non-Siemens controllers or the PC.

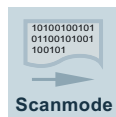

6GT2801-3AB20-0AX1

The RF380R is also available as a scan mode variant (automatic read mode, without command control). This automatic read-only mode does not require a special command control, but supplies the autonomously read transponder data directly to the connected host system.

Due to the high degree of protection and the use of high-quality materials, the SIMATIC RF380R facilitates problem-free operation even under the harshest industrial conditions. It is connected via an 8-pole M12 plug-in connector.

The reader can process the high-speed RF300 transponders and the ISO-15693-compatible transponders (see RFID systems field data table on page 1/10).

Design

Minimum distance from reader to reader

SIMATIC RF380R

≥ 400 mm

Technical specifications



	6GT2801-3AB10	6GT2801-3AB20-0AX1
Article number	6GT2801-3AB10	6GT2801-3AB20-0AX1
Product type designation	RF380R reader	RF380R reader (ISO scan mode)
Suitability for operation	RF300 and ISO 15693 transponders (MDS Dxxx), for connecting to communication modules and PC systems	RF300 and ISO 15693 transponders (MDS Dxxx), for serial connection to control systems (Scan Mode)
Wireless frequencies		
Operating frequency Rated value	13.56 MHz	13.56 MHz
Electrical data		
Range maximum	200 mm; Range adjustable in reader via transmission power, range is dependent on transponder type: observe http://support.automation.siemens.com/WW/view/en/67384964	200 mm
Protocol with radio transmission	RF300-specific, ISO 15693, ISO 18000-3	RF300-specific, ISO 15693, ISO 18000-3
Transfer rate with radio transmission maximum	106 kbit/s	106 kbit/s
Product feature multitag-capable	No	No
Transfer rate at the point-to-point connection serial maximum	115.2 kbit/s	115.2 kbit/s
Transmission time for user data		
• for write access per byte typical	0.13 ms	
• for read access per byte typical	0.13 ms	0.13 ms
Interfaces		
Standard for interfaces for communication	RS422/RS232	RS422/RS232
Type of electrical connection	M12, 8-pin	M12, 8-pin
Mechanical data		
Material	PA 12	PA 12
Color	anthracite	anthracite
Mounting distance relating to metal surfaces recommended minimum	0 mm	0 mm
Supply voltage, current consumption, power loss		
Supply voltage		
• at DC Rated value	24 V	24 V
• at DC	20.4 ... 28.8 V	20.4 ... 28.8 V
Consumed current at DC at 24 V		
• typical	0.16 A	0.16 A
Permitted ambient conditions		
Ambient temperature		
• during operation	-25 ... +70 °C	-25 ... +70 °C
• during storage	-40 ... +85 °C	-40 ... +85 °C
• during transport	-40 ... +85 °C	-40 ... +85 °C
Protection class IP	IP67	IP67
Shock resistance	EN 60721-3-7, Class 7 M2	EN 60721-3-7, Class 7 M2
Shock acceleration	500 m/s ²	500 m/s ²
Vibrational acceleration	200 m/s ²	200 m/s ²
Design, dimensions and weight		
Width	80 mm	80 mm
Height	41 mm	41 mm
Depth	160 mm	160 mm
Net weight	0.6 kg	0.6 kg
Mounting type	4 x M5 screws	4 x M5 screws
Cable length		
• with RS232 interface maximum	30 m	30 m
• for RS422 interface maximum	1 000 m	1 000 m
Product properties, functions, components general		
Display version	3-color LED	3-color LED
Product feature silicon-free	Yes	Yes
Standards, specifications, approvals		
Certificate of suitability	Wireless according to R&TTE guidelines EN 300 330, EN 301489, CE, FCC, UL/CSA, Ex: II 3G Ex nC IIB T5	Wireless according to R&TTE guidelines EN 300 330, EN 301489, CE, FCC, UL/CSA, Ex: II 3G Ex nC IIB T5
MTBF	109 y	109 y

RFID systems for the HF range

SIMATIC RF300 readers

RF380R

Selection and ordering data

	Article No.		Article No.
SIMATIC RF380R reader <ul style="list-style-type: none"> RF300 and ISO15693 modes scan mode 	6GT2801-3AB10 6GT2801-3AB20-0AX1	Accessories Note: All connection options can be found in section 5, "Communication Modules".	
		RS232 connecting cable Between reader and PC (RS232), 5 m long, material: PUR, CMG approval. <ul style="list-style-type: none"> 24 V connection with M12 plug 	6GT2891-4KH50
		<ul style="list-style-type: none"> 24 V connection with open ends 	6GT2891-4KH50-0AX0
		DVD "RFID-Systems Software & Documentation"	6GT2080-2AA20

Dimensional drawings

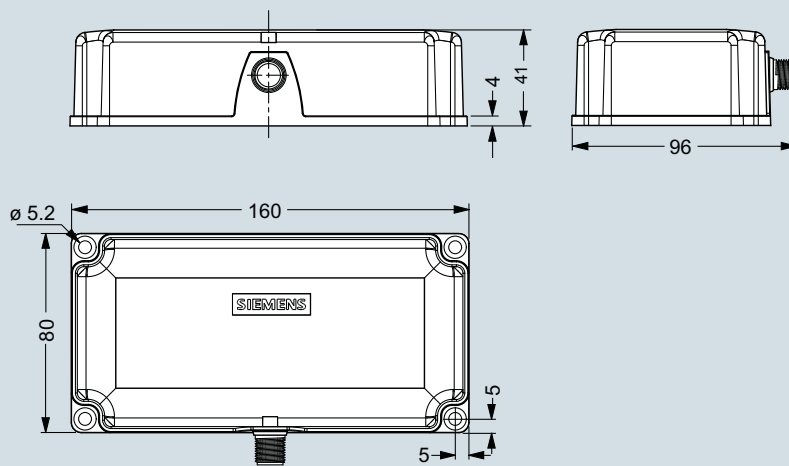

FS10_00285

SIMATIC RF380R reader

More information

All current wireless approvals can be found on the Internet at:

<http://www.siemens.com/rfid-approvals>

Overview



SIMATIC RF382R is a reader with an integral special antenna for the top-end performance range and its compact construction makes it ideal for implementation in conveyor systems in which transponders have to be read from the side (e.g. in the clothing industry or laundry applications). This reader is also particularly suitable for dynamic applications, in which the transponder does not stop during the read/write process.

The reader has both an RS422 interface and an RS232 interface with scan mode functionality. This automatic read-only mode does not require a special command control, but supplies the autonomously read transponder data directly to the connected host system.

Due to the high degree of protection and the use of high-quality materials, the SIMATIC RF382R facilitates problem-free operation even under the harshest industrial conditions. It is connected via an 8-pole M12 plug-in connector.

The reader can process the high-speed RF300 transponders and the ISO-15693-compatible transponders (see RFID systems field data table on page 1/10).

2

Design

Minimum distance from reader to reader

SIMATIC RF382R	≥ 200 mm
----------------	----------

Technical specifications

Article number	6GT2801-3AB20-0AX0
Product type designation	RF382R reader
Suitability for operation	RF300 and ISO 15693 transponders (MDS Dxxx), lateral antenna field, for serial connection to control systems (Scan Mode)
Wireless frequencies	
Operating frequency Rated value	13.56 MHz
Electrical data	
Range maximum	75 mm; Range adjustable in reader via transmission power, range is dependent on transponder type: observe
http://support.automation.siemens.com/WW/view/en/67384964	
Protocol with radio transmission	RF300-specific, ISO 15693, ISO 18000-3
Transfer rate with radio transmission maximum	106 kbit/s
Product feature multitag-capable	No
Transfer rate at the point-to-point connection serial maximum	115.2 kbit/s
Transmission time for user data	
• for read access per byte typical	0.13 ms
Interfaces	
Standard for interfaces for communication	RS422/RS232
Type of electrical connection	M12, 8-pin
Mechanical data	
Material	PA 12
Color	anthracite
Mounting distance relating to metal surfaces recommended minimum	0 mm

Article number	6GT2801-3AB20-0AX0
Product type designation	RF382R reader
Supply voltage, current consumption, power loss	
Supply voltage	
• at DC Rated value	24 V
• at DC	20.4 ... 28.8 V
Consumed current at DC at 24 V	
• typical	0.16 A
Permitted ambient conditions	
Ambient temperature	
• during operation	-25 ... +70 °C
• during storage	-40 ... +85 °C
• during transport	-40 ... +85 °C
Protection class IP	IP67
Shock resistance	EN 60721-3-7, Class 7 M2
Shock acceleration	500 m/s ²
Vibrational acceleration	200 m/s ²



RFID systems for the HF range

SIMATIC RF300 readers

RF382R

Article number	6GT2801-3AB20-0AX0
Product type designation	RF382R reader
Design, dimensions and weight	
Width	80 mm
Height	41 mm
Depth	160 mm
Net weight	0.6 kg
Mounting type	4 x M5 screws
Cable length	
• with RS232 interface maximum	30 m
• for RS422 interface maximum	1 000 m
Product properties, functions, components general	
Display version	3-color LED
Product feature silicon-free	Yes
Standards, specifications, approvals	
Certificate of suitability	Wireless according to R&TTE guidelines EN 300 330, EN 301489, CE, FCC, UL/CSA
MTBF	109 y
Accessories	
Accessories	RS232 connecting cables

Selection and ordering data

	Article No.
SIMATIC RF382R reader RF300 and ISO15693 modes.	6GT2801-3AB20-0AX0
Accessories	
RS232 connecting cable Between reader and PC (RS232), 5 m long, material: PUR, CMG approval.	
• 24 V connection with M12 plug	6GT2891-4KH50
	
• 24 V connection with open ends	6GT2891-4KH50-0AX0
	
DVD "RFID-Systems Software & Documentation"	6GT2080-2AA20

Dimensional drawings

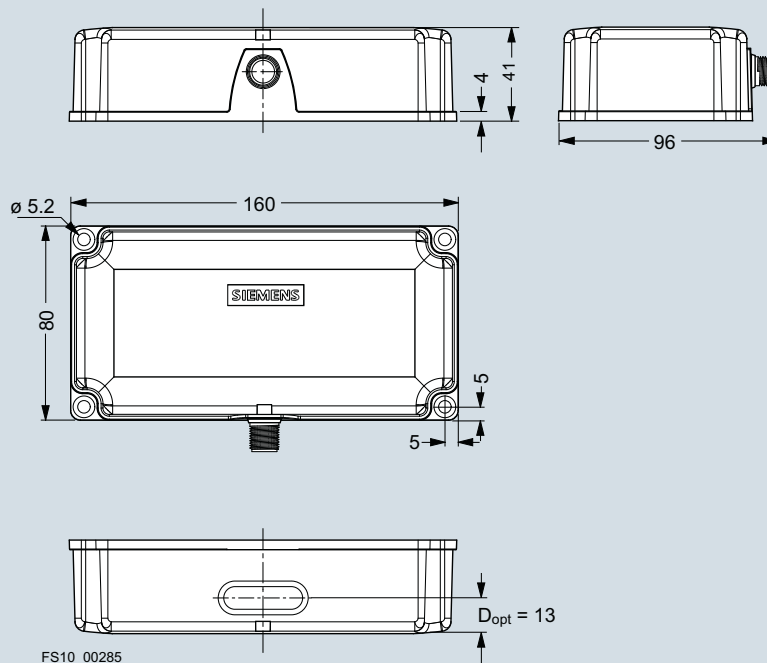

SIMATIC RF382R reader

Overview

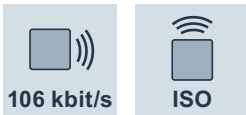

The SIMATIC RF350M is a powerful mobile handheld terminal for applications in the field of production logistics, distribution and service. In addition, it is an indispensable tool for commissioning and testing. The RF350M is equipped either with an integral antenna or with a socket for connecting external antennas.

Design

The SIMATIC RF350M mobile handheld terminal consists of a basic unit (Basis Nordic ID Merlin) and an integrated read/write device for RF300 transponders and transponders of the MDS D-family according to the ISO15693 standard. The read/write device is equipped either with an integrated antenna or with a socket for connecting external antennas.

The SIMATIC RF350M has a splash-proof enclosure (IP54), a color QVGA color touchscreen with a resolution of 320 x 240 pixels, TFT portrait format, an alphanumeric keyboard and various interfaces e.g. for SD memory cards, battery charging and WLAN.

Integral read/write unit, inductive interface to transponder	For SIMATIC RF300 / RF200, MOBY D (ISO)
Read/write distance to the transponder (with integrated antenna)	<ul style="list-style-type: none"> RF300: up to 50 mm ISO: up to 80 mm
Read/write distance to the transponder (with external antenna)	<ul style="list-style-type: none"> RF300: up to 30 mm ISO: up to 60 mm
Energy/data transmission frequency	13.56 MHz
Serial interface (internal, to basic unit)	RS232, 3964R protocol
Functionality of the software application	Standard user interface for reading/writing of transponders, etc.

Function

The supplied and pre-installed software provides the following service and test functions for RF300 and MDS Dxxx transponders¹⁾:

- Reading data from the transponder
- Writing data to the transponder
- Reading and displaying the ID number of the transponder
- Displaying and editing the data in hexadecimal, ASCII, decimal and binary formats

Based on the operating system and communication standard (WIN CE), the unit ensures simple integration into existing or planned infrastructures. Various optional development tools for the PC and a wide selection of accessories are available.

Connectable antennas

One of each of the following antennas can be operated on a SIMATIC RF350M for external antennas:

- ANT 3,
Dimensions L x W x H (mm): 28 x 50 x 10
- ANT 3S,
Dimensions L x W x H (mm): 28 x 50 x 10
- ANT 8,
Dimensions Ø x L (mm): M8 x 38
- ANT 12,
Dimensions Ø x L (mm): M12 x 40
- ANT 18,
Dimensions Ø x L (mm): M18 x 55
- ANT 30,
Dimensions Ø x L (mm): M30 x 58

¹⁾ Exception: The MDS D421, MDS D422, MDS D127 and MDS D117 transponders can only be operated with the SIMATIC RF350M mobile handheld terminal with external antenna..

RFID systems for the HF range

SIMATIC RF300 readers

RF350M mobile handheld terminal

Technical specifications

	6GT2803-1BA00	6GT2803-1BA10
Article number	6GT2803-1BA00	6GT2803-1BA10
Product type designation	RF350M mobile hand-held terminal	RF350M mobile hand-held terminal for external antenna
Suitability for operation	RF300- and RF200/ISO 15693 transponders	RF300- and RF200/ISO 15693 transponders, in particular for small transponders
Range	80 mm	80 mm
Range note		dependent of the type of external antenna
Wireless frequencies		
Operating frequency Rated value	13.56 MHz	13.56 MHz
Electrical data		
Protocol with radio transmission	RF300-specific, ISO 15693, ISO 18000-3	RF300-specific, ISO 15693, ISO 18000-3
Transfer rate with radio transmission maximum	106 kbit/s	106 kbit/s
Product feature multitag-capable	No	No
Supply voltage, current consumption, power loss		
Type of current supply	Battery operation or mains operation via docking station	Battery operation or mains operation via docking station
Type of battery	Lithium ion accumulator, fast charging capability	Lithium ion accumulator, fast charging capability
Type of battery as back-up battery Integrated	Lithium ion battery, permanently installed, cannot be replaced by customer	Lithium ion battery, permanently installed, cannot be replaced by customer
Battery capacity	2.6 Ah	2.6 Ah
Operating period with standard battery typical	8 h	8 h
Permitted ambient conditions		
Ambient temperature		
• during operation	-20 ... +55 °C	-20 ... +55 °C
• during storage	-20 ... +60 °C	-20 ... +60 °C
Relative humidity at 25 °C without condensation during operation maximum	95 %	95 %
Height of fall maximum	1.2 m	1.2 m
Protection class IP	IP54	IP54
Design, dimensions and weight		
Width	90 mm	90 mm
Height	250 mm	250 mm
Depth	47 mm	47 mm
Net weight	0.6 kg	0.6 kg
Product properties, functions, components general		
Design of the display	QVGA color touch screen 3.5 inch, 240 x 320 pixels	QVGA color touch screen 3.5 inch, 240 x 320 pixels
Operator element version	Alphanumeric	Alphanumeric
Design of acoustic signaling element	Speakers	Speakers
Design of the interface	WLAN, USB and Ethernet via charging station	WLAN, USB and Ethernet via charging station
Storage capacity		
• of the RAM	256 Mibyte	256 Mibyte
• of the data and program memory	288 Mibyte	288 Mibyte
• of the data memory can be used	256 Mibyte	256 Mibyte
Product functions management, configuration		
Operating system pre-installed	Windows Embedded CE 6.0	Windows Embedded CE 6.0
Product function of the software	RF350M.exe for execution of RF300 and ISO15693 (RF200, MOBY D) transponders	RF350M.exe for execution of RF300 and ISO15693 (RF200, MOBY D) transponders
Standards, specifications, approvals		
Certificate of suitability	EMC: EN 55022, EN 301 489, EN 300 330, EN 300 328, EN 301 893, safety: EN 60950	EMC: EN 55022, EN 301 489, EN 300 330, EN 300 328, EN 301 893, safety: EN 60950
Accessories		
Accessories	Charging/docking station with USB- and Ethernet interface, changeable accumulator Li-ion 2600 mAh / 7.4 V	Charging/docking station with USB- and Ethernet interface, changeable accumulator Li-ion 2600 mAh / 7.4 V external antenna ANT 3, ANT 3S, ANT 8, ANT 12, ANT 18, ANT 30

Selection and ordering data

	Article No.
SIMATIC RF350M mobile handheld terminal	
<ul style="list-style-type: none"> Basic unit with integrated RFID read/write unit (RF300 and ISO 15693), integrated antenna, battery, standard software pre-installed, without charging/docking station. 	6GT2803-1BA00
<ul style="list-style-type: none"> Basic unit with integrated RFID read/write unit (RF300 and ISO 15693), for external antennas, battery, standard software pre-installed, without charging/docking station, without external antenna. 	6GT2803-1BA10
External antennas for 6GT2803-1BA10	
External antenna ANT 3	6GT2398-1CD30-0AX0
For RF350M mobile handheld terminal (6GT2803-1BA10), without antenna connecting cable. See page 2/132.	
External antenna ANT 3S	6GT2398-1CD50-0AX0
For RF350M mobile handheld terminal (6GT2803-1BA10), without antenna connecting cable. See page 2/133.	
External antenna ANT 8	6GT2398-1CF00
For RF350M mobile handheld terminal (6GT2803-1BA10), without antenna connecting cable. See page 2/134.	
Antenna adapter for ANT 3, ANT 3S and ANT 8	
For direct connection of ANT 3, ANT 3S and ANT 8 to RF350M (6GT2803-1BA10). <ul style="list-style-type: none"> Length 0.1 m 	6GT2898-0EA00
	
<ul style="list-style-type: none"> Length 3 m 	6GT2391-0AH30
External antenna ANT 12	6GT2398-1CC00
For RF350M mobile handheld terminal, with antenna connecting cable. See page 2/136.	
External antenna ANT 18	6GT2398-1CA00
For RF350M mobile handheld terminal, with antenna connecting cable. See page 2/137.	
External antenna ANT 30	6GT2398-1CD00
For RF350M mobile handheld terminal, with antenna connecting cable. See page 2/138.	

Accessories

Note:
All connection options can be found in Chapter 5, "Communication Modules".

Charging/docking station**6GT2803-0BM00**

For a mobile handheld terminal as well as a spare battery, including wide-range plug-in power supply 100 to 240 V AC and country-specific adapters as well as USB cable.

**Spare battery**

For basic device, 2600 mAh, Li-ion batteries.

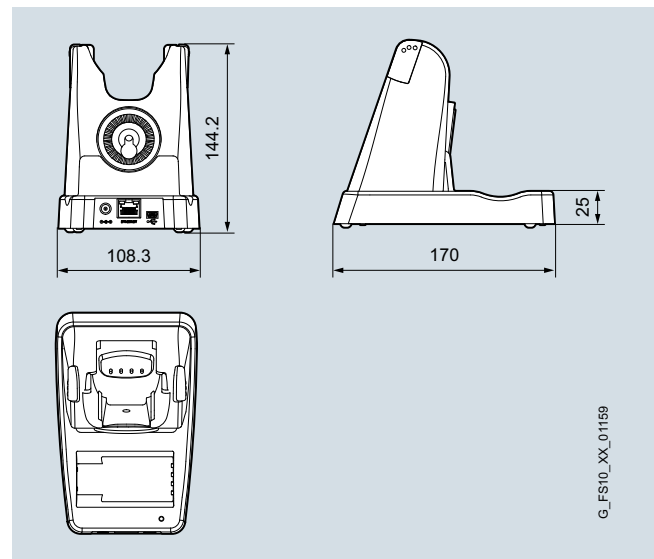
6GT2803-0CA00**DVD „RFID-Systems Software & Documentation“****6GT2080-2AA20****Dimensional drawings**

G_FS10_XX_01159

Docking station for SIMATIC RF350M handheld terminal

More information

All current wireless approvals can be found on the Internet at:
<http://www.siemens.com/rfid-approvals>

RFID systems for the HF range

MOBY D

Introduction

Overview



The MOBY D RFID system is particularly suitable for use in industrial production in the areas of production control, asset management and tracking & tracing.

MOBY D is used for implementing identification tasks with medium performance (ISO 15693) in the HF range (13.56 MHz).

MOBY D offers a comprehensive portfolio of ISO 15693 transponders for a whole variety of requirements - from low-cost SmartLabels for simple identification tasks through rugged credit card formats, right up to transponders for use in especially harsh environments such as paint shops or in the laundry and cleaning industry.

The communication modules that can be used for all MOBY and SIMATIC RF systems (ASM 456, ASM 475, SIMATIC RF 1xxC) are available for connecting to SIMATIC S7-300, PROFIBUS, PROFINET and TCP/IP (XML).

Depending on the read/write distance, different readers are available with integrated or remote antennas.

The MOBY D identification system boasts the following performance features:

- 13.56 MHz operating frequency.
- Operation according to ISO 15693.
- Passive (without battery), maintenance-free transponder (MDS Dxxx) with memory of up to 2 000 bytes FRAM.
- Rugged, compact components with IP68 / IPx9K degree of protection.
- Simple integration in SIMATIC, PROFIBUS, PROFINET and TCP/IP with the help of tried and tested function blocks (FC 45, FB 45).

Benefits

get Designed for Industry

- High-performance reader with bulk detection capability and a range of up to 0.35 m.
- Cost-effective and battery-free ISO 15693 transponders up to 2 KB with IP68 degree of protection and 220 °C temperature range, with ATEX approval.
- Flexible and economic solutions thanks to the complete and scalable portfolio for the field of industrial identification.

- Simplified engineering, commissioning, diagnostics and maintenance through seamless integration into Totally Integrated Automation (TIA):
 - Integrated bus connection to an automation system, such as SIMATIC, SIMOTION or SINUMERIK via communication modules with PROFIBUS and PROFINET.
 - Simple S7 software integration via ready-to-use function blocks.
- High security of investment thanks to:
 - Open ISO 15693 standard.
 - Software compatibility between the RFID systems of Siemens.
 - Standardized communication interfaces.
- Openness through connection possibilities to different bus systems from different manufacturers and PC environments via communication modules.
- Worldwide Service and Support.

Application

- High-performance reader with bulk detection capability and a range of up to 0.35 m.
- Cost-effective and battery-free ISO 15693 transponders up to 2 KB with IP68 degree of protection and 220 °C temperature range, with ATEX approval.
- Flexible and economic solutions thanks to the complete and scalable portfolio for the field of industrial identification.
- Simplified engineering, commissioning, diagnostics and maintenance through seamless integration into Totally Integrated Automation (TIA):
 - Integrated bus connection to an automation system, such as SIMATIC, SIMOTION or SINUMERIK via communication modules with PROFIBUS and PROFINET.
 - Simple S7 software integration via ready-to-use function blocks.
- High security of investment thanks to:
 - Open ISO 15693 standard.
 - Software compatibility between the RFID systems of Siemens.
 - Standardized communication interfaces.
- Openness through connection possibilities to different bus systems from different manufacturers and PC environments via communication modules.
- Worldwide Service and Support.

Design

The MOBY D readers are available in different designs. In addition to the SLG D12 and SLG D12S readers with integrated antennas, the SLG D11 and SLG D11S readers permit the connection of various external antennas with which extended ranges of up to 380 mm can be achieved.

The high degree of protection of up to IP65 enables the MOBY D readers to be used in harsh, industrial environments.

The interface to the automation level can be implemented by means of communication modules. For quick and easy cabling, pre-assembled cables with M12 plug-in connectors are available in various lengths.

The MOBY D transponders compliant with ISO 15693 are used as mobile data carriers.

Transponders suitable for a wide variety of different requirements can be selected from an extensive range: From low-cost SmartLabels for simple identification tasks, through rugged credit card formats, right up to screw-fit transponders that can be automatically attached by robots.

The transponders are attached to the object to be identified, e.g. by means of screws, adhesive or pre-assembled spacer.

Function

All MOBY D readers are suitable for reliable reading and writing tasks in the HF range.

The readers are equipped either with an RS232 interface for the connection to the PC or to SIMATIC S7-1200 or with an RS422 interface for the connection via communication modules to the automation level (e.g. SIMATIC S7) via standard fieldbuses (e.g. PROFIBUS or PROFINET).

User-friendly function blocks are available for the S7 programming.

In the event of an error, the S7 application receives a detailed error message from the communication module via the function block.

Integration

A wide range of communication modules, function blocks, as well as high-performance drivers and function libraries permits easy and quick integration into the application.

And best of all: MOBY D is part of Totally Integrated Automation (TIA) and can be integrated easily and cost-effectively into the SIMATIC world.

For more details on the connection possibilities, see the section 5 "Communication Modules".

SIMATIC Ident Configuration Guide

Here is a compact configuration tool for setting up RFID systems:

<http://support.automation.siemens.com/WW/view/en/67384964>

Technical specifications





RFID system	MOBY D
Transmission frequency	13.56 MHz
Range	Max. 380 mm
Protocol (air interface)	<ul style="list-style-type: none"> • ISO 15693 • ISO 18000-3
Approvals	<ul style="list-style-type: none"> • EN 300330, 301489, CE • FCC Part 15 • UL/CSA
Memory capacity	992 bytes (EEPROM) / 2 000 bytes (FRAM)
Data transmission rate reader – transponder	
<ul style="list-style-type: none"> • Read • Write 	Max. 1.5 kbyte/s Max. 0.5 kbyte/s
Multitag/Bulk capability	Yes
Special features	<ul style="list-style-type: none"> • SIMATIC or PC/IT integration • Long sensing ranges with excellent interference immunity • External antennas for industrial applications

RFID systems for the HF range

MOBY D readers

Introduction

Overview

Readers	Features	Page	Readers	Features	Page
SLG D11 basic unit 	Reader for connection of an external antenna (ANT D2 / ANT D5). With RS232 interface for connection to PC/PLC.	2/123	SLG D12 	Universal reader with integrated antenna. With RS232 interface for connection to PC/PLC.	2/126
SLG D11S basic unit 	Like SLG D11, but with RS422 interface for connection to SIMATIC S7 / PROFIBUS / PROFINET / Ethernet TCP/IP via ASM 456, ASM 475, SIMATIC RF120C, RF160C, RF170C, RF180C or RF182C.	2/123	SLG D12S 	Like SLG D12, but with RS422 interface for connection to SIMATIC S7 / PROFIBUS / PROFINET / Ethernet TCP/IP via ASM 456, ASM 475, SIMATIC RF120C, RF160C, RF170C, RF180C or RF182C.	2/126

Overview

The SLG D11/SLG D11S basic units are readers in the mid-performance range and can be operated with the ANT D2 and ANT D5 antennas.

SLG D11

Equipped with RS232 serial interface for connection to PC/PLC.

SLG D11S

Equipped with an RS422 serial interface, which permits communication via the communication modules ASM 456, ASM 475, SIMATIC RF120C, RF160C, RF170C and SIMATIC RF180C, or RF182C to SIMATIC S7, PROFIBUS/PROFINET or Ethernet TCP/IP.

Connectable antennas
ANT D2

The ANT D2 antenna is designed for transponders that are directed sideways past the antenna. This antenna is specially designed for high speeds, e.g. in overhead conveyors, assembly lines, production and order picking. It can be mounted directly onto metal surfaces. Description see page 2/140.

ANT D5

The ANT D5 is a universal antenna designed for warehouse, logistics and distribution applications. The high degree of protection (IP65) enables the antenna to be used under harsh industrial conditions. A spacer kit is required for mounting on metal surfaces. Description see page 2/141.

Technical specifications

	6GT2698-1AC00	6GT2698-2AC00
Article number	6GT2698-1AC00	6GT2698-2AC00
Product type designation	SLG D11 reader	SLG D11S reader
Suitability for operation	ISO 15693 transponders (MDS Dxxx), for connecting to PC systems	ISO 15693 transponders (MDS Dxxx), for connecting to communication modules
Wireless frequencies		
Operating frequency Rated value	13.56 MHz	13.56 MHz
Electrical data		
Range maximum	380 mm; Range is dependent on transponder type: observe http://support.automation.siemens.com/WWW/view/en/67384964	
Protocol with radio transmission	ISO 15693, ISO 18000-3	ISO 15693, ISO 18000-3
Transfer rate with radio transmission maximum	26.5 kbit/s	26.5 kbit/s
Product feature multitag-capable	Yes	No
Transfer rate at the point-to-point connection serial maximum	38.4 kbit/s	19.2 kbit/s
Transmission time for user data		
• for write access per byte typical	2.5 ms	2.5 ms
• for read access per byte typical	2.5 ms	2.5 ms
Interfaces		
Number of external antennas	1	1
Standard for interfaces for communication	RS232	RS422
Type of electrical connection		
• for external antenna(s)	TNC	TNC
• for supply voltage	M12, 4-pin, female connector	M12, 4-pin, female connector
• for communications interface	Sub-D, 9-pin, male	Sub-D, 9-pin, male
Mechanical data		
Material	PA 12	PA 12
Color	anthracite	anthracite
Tightening torque of the screw for securing the equipment maximum	2 Nm	2 Nm
Mounting distance relating to metal surfaces recommended minimum	0 mm	0 mm



RFID systems for the HF range

MOBY D readers

SLG D11/SLG D11S basic unit for ANT D2 and ANT D5 antennas

	6GT2698-1AC00	6GT2698-2AC00
Article number	SLG D11 reader	SLG D11S reader
Product type designation		
Supply voltage, current consumption, power loss		
Supply voltage		
• at DC Rated value	24 V	24 V
• at DC	20 ... 30 V	20 ... 30 V
Consumed current at DC at 24 V		
• typical	0.2 A	0.2 A
• maximum	0.6 A	0.6 A
Permitted ambient conditions		
Ambient temperature		
• during operation	-25 ... +55 °C	-25 ... +55 °C
• during storage	-25 ... +70 °C	-25 ... +70 °C
• during transport	-25 ... +70 °C	-25 ... +70 °C
Protection class IP	IP65	IP65
Shock resistance	EN 60721-3-7 Class 7 M2	EN 60721-3-7 Class 7 M2
Shock acceleration	300 m/s ²	300 m/s ²
Vibrational acceleration	15 m/s ²	15 m/s ²
Design, dimensions and weight		
Width	80 mm	80 mm
Height	40 mm	40 mm
Depth	160 mm	160 mm
Net weight	0.26 kg	0.26 kg
Mounting type	2 x M5 screws	2 x M5 screws
Cable length		
• of antenna cable minimum	3.3 m	3.3 m
• of antenna cable maximum	10.5 m	10.5 m
• with RS232 interface maximum	30 m	
• for RS422 interface maximum		300 m
Standards, specifications, approvals		
Certificate of suitability	CE, FCC, IC (Canada), UL 60950, safe for cardiac pacemakers	CE, FCC, IC (Canada), UL 60950, safe for cardiac pacemakers
MTBF	23 y	23 y
Accessories		
Accessories	Various antennas are available, Wide-range power supply, connectors and cables	Various antennas are available, Wide-range power supply, connectors and cables

Selection and ordering data

	Article No.
SLG D11 reader Basic unit (without antenna) with RS232 serial interface for connection to PC/PLC.	6GT2698-1AC00
SLG D11S reader Basic unit (without antenna) with RS422 serial interface for connection to SIMATIC S7/PROFIBUS/PROFINET via communication module.	6GT2698-2AC00
Accessories Note: All connection options can be found in section 5, "Communication Modules".	
Antenna ANT D2 For SLG D11 / SLG D11S basic units, incl. antenna cable, PVC, length 3.3 m. See page 2/140.	6GT2698-5BB00
Antenna ANT D5 For SLG D11 / SLG D11S basic units. See page 2/141.	6GT2698-5AA10
Wide-range power supply 100 V ... 240 V AC / 24 V DC, 3 A With no-load protection, with continuous short-circuit protection <ul style="list-style-type: none"> • With EU plug • With UK plug • With US plug 	6GT2898-0AA00 6GT2898-0AA10 6GT2898-0AA20
Connecting cable for 24 V DC For wide-range power supply, PUR, length 5 m. 	6GT2491-1HH50
24 V connector (M12 socket) For SLG D1x reader. 	6GT2390-1AB00
RS232 cable for SLG D11, PUR 	6GT2691-4BH50 6GT2691-4BN20
DVD „RFID-Systeme Software & Dokumentation“	6GT2080-2AA20

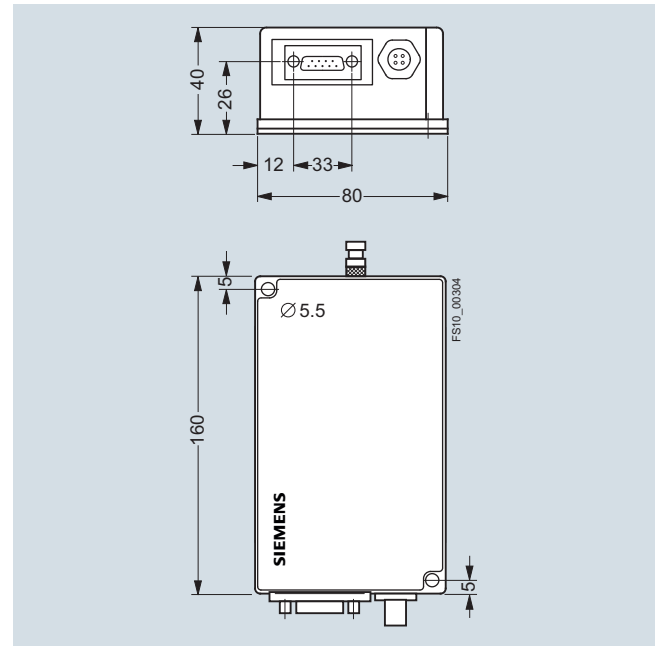
Dimensional drawings

SLG D11 / SLG D11S reader - basic unit

More information

All current wireless approvals can be found on the Internet at:
<http://www.siemens.com/rfid-approvals>

RFID systems for the HF range

MOBY D readers

SLG D12 / SLG D12S

Overview



The SLG D12 / SLG D12S basic devices are universal readers in the medium performance range with integral antennas.

SLG D12

Equipped with RS232 serial interface for connection to PC/PLC.

SLG D12S

Equipped with an RS422 serial interface, which permits communication via the communication modules ASM 456, ASM 475, SIMATIC RF120C, RF160C, RF170C and SIMATIC RF180C, or RF182C to SIMATIC S7, PROFIBUS/PROFINET or Ethernet TCP/IP.



RS232



ISO

6GT2601-0AB00



CM



ISO





6GT2602-0AB00 and
6GT2602-0AB10-0AX0

Technical specifications

Article number	6GT2601-0AB00	6GT2602-0AB00	6GT2602-0AB10-0AX0
Product type designation	SLG D12 reader	SLG D12S reader	SLG D12S reader
Suitability for operation	ISO 15693 transponders (MDS Dxxx), for connecting to PC systems	ISO 15693 transponders (MDS Dxxx), for connecting to communication modules	ISO 15693 transponders (MDS Dxxx), for connecting to communication modules
Wireless frequencies			
Operating frequency Rated value	13.56 MHz	13.56 MHz	13.56 MHz
Electrical data			
Range maximum	220 mm; Range is dependent on transponder type: observe http://support.automation.siemens.com/WWW/view/en/67384964		
Protocol with radio transmission	ISO 15693, ISO 18000-3	ISO 15693, ISO 18000-3	ISO 15693, ISO 18000-3
Transfer rate with radio transmission maximum	26.5 kbit/s	26.5 kbit/s	26.5 kbit/s
Product feature multitag-capable	Yes	No	No
Transfer rate at the point-to-point connection serial maximum	38.4 kbit/s	19.2 kbit/s	19.2 kbit/s
Transmission time for user data			
• for write access per byte typical	2.5 ms	2.5 ms	2.5 ms
• for read access per byte typical	2.5 ms	2.5 ms	2.5 ms
Interfaces			
Standard for interfaces for communication	RS232	RS422	RS422
Type of electrical connection	Data: Sub-D, 9-pin, male, voltage: M12, 4-pin, female connector	Data: Sub-D, 9-pin, male, voltage: M12, 4-pin, female connector	M12, 8-pin
Mechanical data			
Material	PA 12	PA 12	PA 12
Color	anthracite	anthracite	anthracite
Tightening torque of the screw for securing the equipment maximum	2 Nm	2 Nm	2 Nm
Mounting distance relating to metal surfaces recommended minimum	0 mm	0 mm	0 mm
Supply voltage, current consumption, power loss			
Supply voltage			
• at DC Rated value	24 V	24 V	24 V
• at DC	20 ... 30 V	20 ... 30 V	20 ... 30 V
Consumed current at DC at 24 V			
• typical	0.15 A	0.15 A	0.15 A
• maximum	0.6 A	0.6 A	0.6 A

Article number	6GT2601-0AB00	6GT2602-0AB00	6GT2602-0AB10-0AX0
Product type designation	SLG D12 reader	SLG D12S reader	SLG D12S reader
Permitted ambient conditions			
Ambient temperature			
• during operation	-25 ... +55 °C	-25 ... +55 °C	-25 ... +55 °C
• during storage	-25 ... +70 °C	-25 ... +70 °C	-25 ... +70 °C
• during transport	-25 ... +70 °C	-25 ... +70 °C	-25 ... +70 °C
Protection class IP	IP65	IP65	IP65
Shock resistance	EN 60721-3-7 Class 7 M2	EN 60721-3-7 Class 7 M2	EN 60721-3-7 Class 7 M2
Shock acceleration	300 m/s ²	300 m/s ²	300 m/s ²
Vibrational acceleration	15 m/s ²	15 m/s ²	15 m/s ²
Design, dimensions and weight			
Width	80 mm	80 mm	80 mm
Height	40 mm	40 mm	40 mm
Depth	160 mm	160 mm	160 mm
Net weight	0.23 kg	0.23 kg	0.23 kg
Mounting type	2 x M5 screws	2 x M5 screws	2 x M5 screws
Cable length			
• with RS232 interface maximum	30 m		
• for RS422 interface maximum		300 m	300 m
Standards, specifications, approvals			
Certificate of suitability	CE, FCC, IC (Canada), UL 60950, safe for cardiac pacemakers	CE, FCC, IC (Canada), UL 60950, safe for cardiac pacemakers	CE, FCC, IC (Canada), UL 60950, safe for cardiac pacemakers
MTBF	23 y	23 y	23 y
Accessories			
Accessories	Wide-range power supply, connectors, cables	Wide-range power supply, connectors, cables	Wide-range power supply, connectors, cables

Selection and ordering data

	Article No.		Article No.
SLG D12 reader	6GT2601-0AB00	Connector for reader	6GT2490-1AA00
With RS232 serial interface and integrated antenna.		IP65 degree of protection, 9-pin Sub-D connector.	
SLG D12S reader	6GT2602-0AB00		
With RS422 serial interface and integrated antenna for connection to SIMATIC S7 / PROFIBUS / PROFINET or Ethernet TCP/IP.		Wide-range power supply	
SLG D12S reader, for single-cable connection	6GT2602-0AB10-0AX0	Primary side: AC 100 ... 240 V, secondary side: 24 V DC, 3 A, with no-load protection and continuous short-circuit protection.	
With RS422 serial interface and integrated antenna. Only one connector for data and voltage supply. Power supply via communication module.		• EU connector version	6GT2898-0AA00
Connector: M12, 8-pin (male)		• UK connector version	6GT2898-0AA10
Accessories		• US connector version	6GT2898-0AA20
Note: All connection options can be found in section 5, "Communication Modules".		Cable for wide-range power supply	6GT2491-1HH50
RS232 connecting cable		24 V DC, PUR, length 5 m.	
Between PC and SLG D12, PUR.			
	6GT2691-4BH50	24 V connector (M12 socket)	6GT2390-1AB00
5 m		for SLG D1x readers	
20 m	6GT2691-4BN20		
		DVD „RFID-Systems Software & Documentation“	6GT2080-2AA20

RFID systems for the HF range

MOBY D readers

SLG D12 / SLG D12S

Dimensional drawings

More information

All current wireless approvals can be found on the Internet at:

<http://www.siemens.com/rfid-approvals>

2

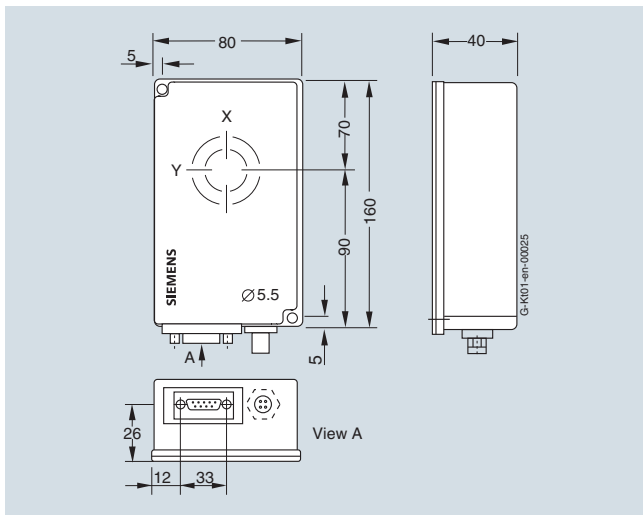

SLG D12 / SLG D12S reader, basic unit

Overview

Note

Detailed configuration and commissioning data is contained in the "Manual for Configuration, Assembly and Service".

Transmission window

The reader generates an inductive alternating field. The field is at its strongest near the antenna and declines considerably as the distance from the antenna increases. The distribution of the field depends on the structure and geometry of the antennas in the reader and transponder.

A prerequisite for the function of the transponder is a minimum field strength at the transponder that is achieved at a distance S_g from the reader. The picture below shows the transmission window between the transponder and reader:

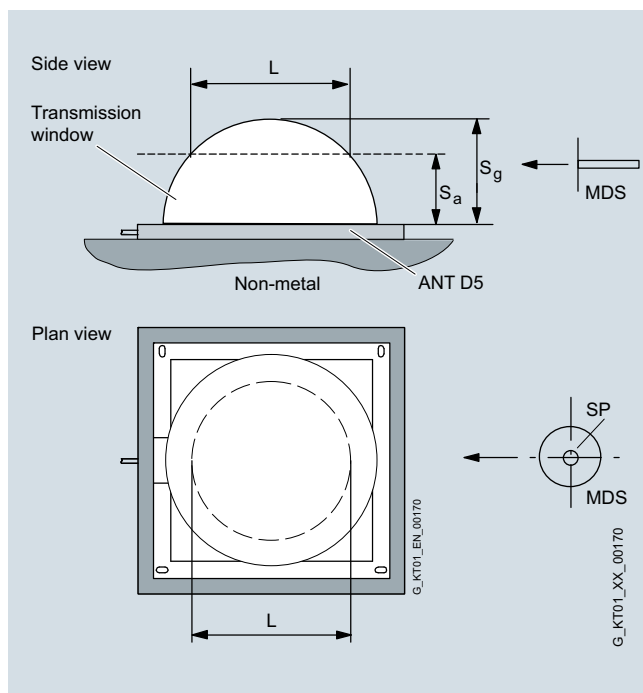
Traversing speed for SLG D1x / ANT Dx
(with one transponder in the field)

Reader	SLG D11		SLG D12	SLG D11S		SLG D12S
	ANT D2	ANT D5		ANT D2	ANT D5	
Antenna						
UID number (8 bytes)	≤ 1.2	≤ 3.5	≤ 2.5	≤ 0.4	≤ 1.0	≤ 0.8
ISO transponder, e.g. MDS D100						
Read (with 4 bytes of user data / 1 block)	≤ 1.2	≤ 1.6	≤ 1.2	≤ 0.4	≤ 3.0	≤ 1.4
Write (with 4 bytes of user data / 1 block)	≤ 0.2	≤ 1.2	≤ 1.0	≤ 0.3	≤ 2.8	≤ 1.2
Read (with 112 bytes of complete user data)	≤ 0.4	≤ 1.4	≤ 0.8	≤ 0.2	≤ 2.2	≤ 1.0
Write (with 112 bytes of complete user data)	≤ 0.1	≤ 0.4	≤ 0.2	≤ 0.1	≤ 0.5	≤ 0.2

All values in the table in m/s.

S_a : Operating distance between transponder and reader

S_g : Limit distance (maximum clear distance between upper surface of antenna and transponder, at which the transmission can still function under normal conditions)

L: Length of a transmission window

SP: Intersection of the axes of symmetry of the transponder

The transmittable quantity of information between reader and transponder depends on:

- the speed at which the transponder passes the antenna ("passing speed")
- Length of the inductive alternating field of the reader, through which the transponder moves ("transmission window").

Communication between reader and transponder

Communication between the reader and transponder is asynchronous.

Data transfer, reader - transponder	
Read	≥ 3.5 ms/byte
Write	≥ 9.5 ms/byte (EEPROM)
Transmission time of ID number	
• SLG D12S ANT D5, ANT D6, ANT D10	90 ms (8 bytes at 19.2 Kbit/s)
• SLG D11S ANT D5	
• SLG D12 ANT D5, ANT D6, ANT D10	60 ms (8 bytes at 38.4 Kbit/s)
• SLG D11 ANT D5	

RFID systems for the HF range

HF antennas

Introduction

Overview

Antennas	Features	Page	Antennen	Merkmale	Page
ANT 1 	<p>The ANT 1 is a universal flat antenna, also designed for dynamic applications.</p> <p>Usable for readers:</p> <ul style="list-style-type: none"> • RF350R 	2/131	ANT D1 	<p>The ANT D1 is a universal antenna for the areas of production and logistics that can also be used in dynamic applications.</p> <p>Usable for readers:</p> <ul style="list-style-type: none"> • RF290R 	2/139
ANT 3 	<p>Due to its slimline, compact design, the ANT 3 antenna can still be precisely positioned even in cramped conditions.</p> <p>Usable for readers:</p> <ul style="list-style-type: none"> • RF250R • RF350R • RF350M 	2/132	ANT D2 	<p>The ANT D2 antenna is specially designed for high speeds with a small antenna size, e.g. in overhead conveyors, assembly lines, production and order picking.</p> <p>The ANT D2 can be mounted directly onto metal surfaces.</p> <p>The antenna is designed for transponders that are directed sideways past the antenna.</p> <p>Usable for readers:</p> <ul style="list-style-type: none"> • SLG D11 / SLG D11S 	2/140
ANT 3S 	<p>Due to its slimline, compact design, the ANT 3S antenna can still be precisely positioned even in cramped conditions.</p> <p>The ANT 3S is suitable only for use with transponders MDS D117, MDS D127, MDS D421 and MDS D521.</p> <p>Usable for readers:</p> <ul style="list-style-type: none"> • RF250R • RF350R • RF350M 	2/133	ANT D5 	<p>The ANT D5 is a universal antenna designed for warehouse, logistics and distribution applications.</p> <p>The high degree of protection (IP65) enables the antenna to be used under harsh industrial conditions.</p> <p>The antenna is designed for transponders that are directed sideways past the antenna.</p> <p>Usable for readers:</p> <ul style="list-style-type: none"> • RF290R • SLG D11 / SLG D11S 	2/141
ANT 8 	<p>The ANT 8 antenna is a cylindrical antenna and is intended predominantly for the area of tool identification.</p> <p>The extremely small design of the antenna allows extremely accurate positioning.</p> <p>Usable for readers:</p> <ul style="list-style-type: none"> • RF250R • RF350M 	2/134	ANT D6 	<p>The ANT D6 is a universal antenna designed for warehouse, logistics and distribution applications.</p> <p>The high degree of protection (IP65) enables the antenna to be used under harsh industrial conditions.</p> <p>Usable for readers:</p> <ul style="list-style-type: none"> • RF290R 	2/143
ANT 12 	<p>The ANT 12 antenna is a universal round antenna in M12 design for assembly lines with extremely small workpiece holders.</p> <p>Usable for readers:</p> <ul style="list-style-type: none"> • RF250R • RF350R • RF350M 	2/136	ANT D10 	<p>The ANT D10 is a universal antenna. It has been designed for warehouse, logistics and distribution applications, and is especially suitable for the clothing industry and laundries. It possesses an advantageous geometry for use with small transponders and a long transmission field.</p> <p>The high degree of protection (IP65) enables the antenna to be used under harsh industrial conditions.</p> <p>Usable for readers:</p> <ul style="list-style-type: none"> • RF290R 	2/145
ANT 18 	<p>The ANT 18 antenna is a universal round antenna in M18 design for assembly lines with small workpiece holders.</p> <p>Usable for readers:</p> <ul style="list-style-type: none"> • RF250R • RF350R • RF350M 	2/137			
ANT 30 	<p>The ANT 30 antenna is a universal round antenna in M30 design for assembly lines with small workpiece holders.</p> <p>Usable for readers:</p> <ul style="list-style-type: none"> • RF250R • RF350R • RF350M 	2/138			

Overview



The ANT 1 is a universal flat antenna, also designed for dynamic applications.

The dimensions are L x W x H (mm): 75 x 75 x 20.

Technical specifications

Article number	6GT2398-1CB00
Product type designation	ANT 1 antenna
Suitability for operation	RF350R / MOBY E
Wireless frequencies	
Transmission frequency Rated value	13.56 MHz
Electrical data	
Type of electrical connection of the antenna	M8, 4-pin
Design of plug-in connection	male
Mechanical data	
Material	PA 12
Color	Anthracite
Tightening torque of the screw for securing the equipment maximum	2 Nm
Mounting distance	
• relating to metal surfaces recommended minimum	0.02 m
Permitted ambient conditions	
Ambient temperature	
• during operation	-25 ... +70 °C
• during storage	-40 ... +85 °C
• during transport	-40 ... +85 °C
Protection class IP	IP67
Resistance to mechanical stress	no bending or torsion permitted
Shock resistance	according to EN 60721-3-7 Class 7M2
Shock acceleration	500 m/s ²
Vibrational acceleration	200 m/s ²
Design, dimensions and weight	
Width	75 mm
Height	75 mm
Depth	20 mm
Net weight	225 g
Mounting type	2 screws M5
Cable length of antenna cable	3 m
Standards, specifications, approvals	
Certificate of suitability	CE, FCC, IC, cULus, Ex approval only together with reader 6GT2801-4AB10

Selection and ordering data

	Article No.
ANT 1 external antenna	6GT2398-1CB00
for RF350R readers.	
The antenna cable (3m long) is permanently connected to the antenna.	

Dimensional drawings

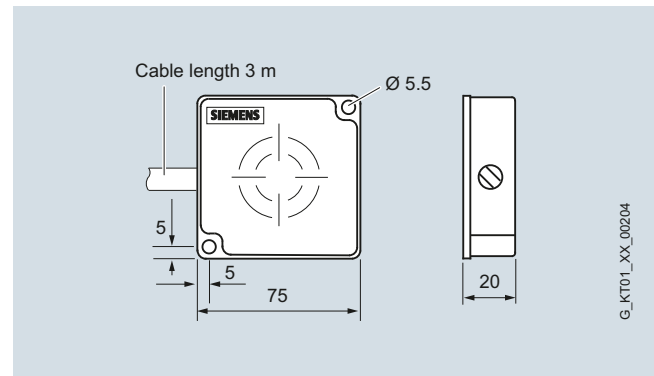

ANT 1 antenna

RFID systems for the HF range

HF antennas

ANT 3 for RF250R, RF350R and RF350M

Overview

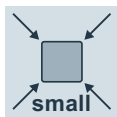

Due to its slimline, compact design, the ANT 3 antenna can still be precisely positioned even in cramped conditions.

The dimensions are L x W x H (mm): 50 x 28 x 10.

Technical specifications

Article number	6GT2398-1CD30-0AX0	6GT2398-1CD40-0AX0
Product type designation	ANT 3 antenna	ANT 3 antenna incl. antenna cable (3 m)
Suitability for operation	RF250R / RF350R / RF350M	RF250R / RF350R
Wireless frequencies		
Transmission frequency Rated value	13.56 MHz	
Electrical data		
Type of electrical connection of the antenna	M8, 4-pin	
Design of plug-in connection	female	male
Mechanical data		
Material	PA6 V0	
Color	black	
Tightening torque of the screw for securing the equipment maximum	1 Nm	
Mounting distance	0 m	
• relating to metal surfaces recommended minimum		
Permitted ambient conditions		
Ambient temperature		
• during operation	-25 ... +70 °C	
• during storage	-40 ... +85 °C	
• during transport	-40 ... +85 °C	
Protection class IP	IP67	
Shock resistance	according to EN 60721-3-7 Class 7M2	
Shock acceleration	500 m/s ²	
Vibrational acceleration	200 m/s ²	

Article number	6GT2398-1CD30-0AX0	6GT2398-1CD40-0AX0
Design, dimensions and weight		
Width	28 mm	
Height	50 mm	
Depth	10 mm	
Net weight	35 g	160 g
Mounting type	2 x M4 screws	2 x M4 screws
Cable length of antenna cable	-	3 m
Standards, specifications, approvals		
Certificate of suitability	CE, FCC, IC, cULus	
Accessories		
Antenna cable	-	Included: 6GT23910-AH30 (antenna cable)

Selection and ordering data

	Article No.
ANT 3 external antenna	
• Without antenna connecting cable For RF250R, RF350R and RF350M readers.	6GT2398-1CD30-0AX0
• With antenna connecting cable included in the scope of delivery; can be connected at both ends (connector M8 straight / M8 angled), length 3 m. For RF250R and RF350R readers.	6GT2398-1CD40-0AX0
Accessories	
Antenna connecting cable for ANT 3 / ANT 3S / ANT 8	
For direct connection of ANT 3, ANT 3S and ANT 8 to RF350M	
• Length 0.1 m (figure see page 2/119)	6GT2898-0EA00
• Length 3 m	6GT2391-0AH30

Dimensional drawings

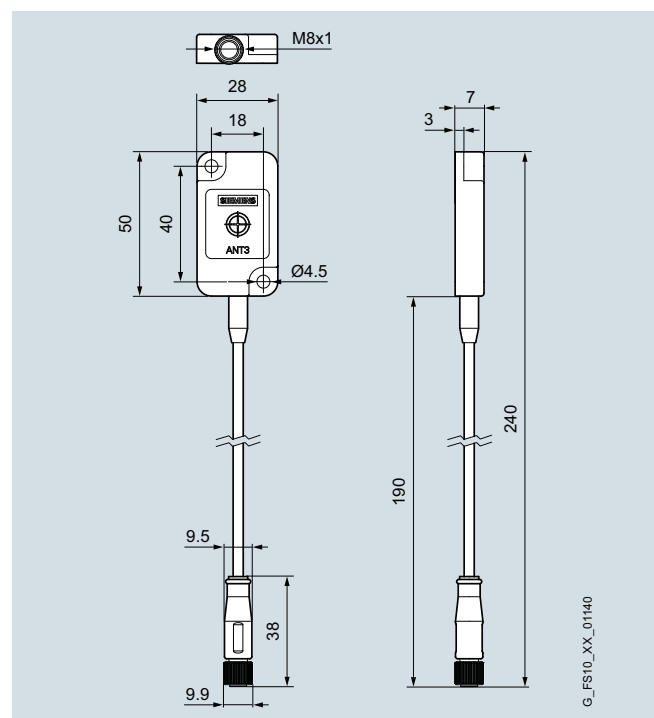

ANT 3 antenna

G_FS10_XX_01140

Overview

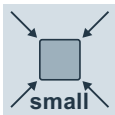

Due to its slimline, compact design, the ANT 3S antenna can still be precisely positioned even in cramped conditions.

The ANT 3S is suitable only for use with transponders MDS D117, MDS D127, MDS D421 and MDS D521.

The dimensions of the antenna are L x W x H (mm): 50 x 28 x 10.

Technical specifications

Article number	6GT2398-1CD50-0AX0	6GT2398-1CD60-0AX0
Product type designation	ANT 3S antenna	ANT 3S antenna including antenna cable (3 m)
Suitability for operation	RF250R / RF350R / RF350M	RF250R / RF350R
Wireless frequencies		
Transmission frequency Rated value	13.56 MHz	
Electrical data		
Type of electrical connection of the antenna	M8, 4-pin	
Design of plug-in connection	female	male
Mechanical data		
Material	PA6 V0	
Color	black	
Tightening torque of the screw for securing the equipment maximum	1 Nm	
Mounting distance	0 m	
• relating to metal surfaces recommended minimum		
Permitted ambient conditions		
Ambient temperature		
• during operation	-25 ... +70 °C	
• during storage	-40 ... +85 °C	
• during transport	-40 ... +85 °C	
Protection class IP	IP67	
Shock resistance	according to EN 60721-3-7 Class 7M2	
Shock acceleration	500 m/s ²	
Vibrational acceleration	200 m/s ²	

Article number	6GT2398-1CD50-0AX0	6GT2398-1CD60-0AX0
Design, dimensions and weight		
Width	28 mm	
Height	50 mm	
Depth	10 mm	
Net weight	35 g	160 g
Mounting type	2 x M4 screws	2 x M4 screws
Cable length of antenna cable	-	3 m
Standards, specifications, approvals		
Certificate of suitability	CE, FCC, IC, cULus	
Accessories	Antenna cable	Included: 6GT23910-AH30 (antenna cable)

Selection and ordering data

	Article No.
ANT 3S external antenna	
• Without antenna connecting cable For RF250R, RF350R and RF350M readers.	6GT2398-1CD50-0AX0
• With antenna connecting cable included in the scope of delivery; can be connected at both ends (connector M8 straight / M8 angled), length 3 m. For RF250R and RF350R readers.	6GT2398-1CD60-0AX0
Accessories	
Antenna connecting cable for ANT 3 / ANT 3S / ANT 8	
For direct connection of ANT 3, ANT 3S and ANT 8 to RF350M (6GT2803-1BA10).	
• Length 0.1 m (figure see page 2/119)	6GT2898-0EA00
• Length 3 m	6GT2391-0AH30

Dimensional drawings

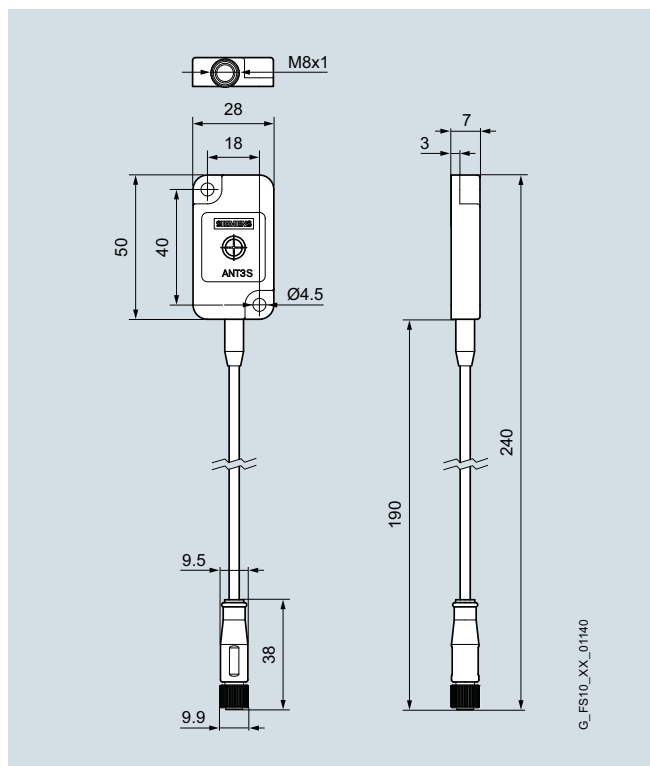

ANT 3S antenna

RFID systems for the HF range

HF antennas

ANT 8 for RF250R and RF350M

Overview

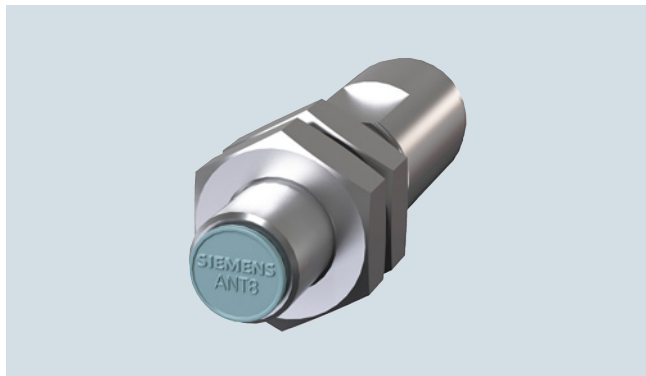

The ANT 8 antenna is a cylindrical antenna and is intended predominantly for the area of tool identification. The extremely small design of the antenna allows extremely accurate positioning. Dimensions $\varnothing \times L$ (mm): M8 x 38.

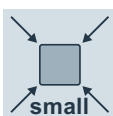

Technical specifications

	6GT2398-1CF00	6GT2398-1CF10
Article number	6GT2398-1CF00	6GT2398-1CF10
Product type designation	ANT 8 antenna	ANT 8 antenna incl. antenna cable
Suitability for operation	RF250R / RF350M	RF250R
Wireless frequencies		
Transmission frequency Rated value	13.56 MHz	13.56 MHz
Electrical data		
Type of electrical connection of the antenna	M8, 4-pin	M8, 4-pin
Design of plug-in connection	female	male
Mechanical data		
Material	Stainless steel V2A	Stainless steel V2A
Color	Silver	Silver
Tightening torque of the screw for securing the equipment maximum	3 Nm	3 Nm
Mounting distance		
• relating to metal surfaces recommended minimum	0 m	0 m
Permitted ambient conditions		
Ambient temperature		
• during operation	-25 ... +70 °C	-25 ... +70 °C
• during storage	-40 ... +85 °C	-40 ... +85 °C
• during transport	-40 ... +85 °C	-40 ... +85 °C
Protection class IP	IP67, front	IP67, front
Shock resistance	according to EN 60721-3-7 Class 7M2	according to EN 60721-3-7 Class 7M2
Shock acceleration	500 m/s ²	500 m/s ²
Vibrational acceleration	200 m/s ²	200 m/s ²
Design, dimensions and weight		
Depth	40 mm	40 mm
Diameter	8 mm	8 mm
Net weight	10 g	140 g
Mounting type	2 stainless steel cscrew nuts M8 x 1.0 (included)	2 stainless steel cscrew nuts M8 x 1.0 (included)
Cable length of antenna cable		3 m
Standards, specifications, approvals		
Certificate of suitability	CE, FCC, IC, cULus	CE, FCC, IC, cULus
Accessories		
Accessories	Antenna cable	Included: 6GT23910-AH30 (antenna cable, length 3 m)

Selection and ordering data

	Article No.
<p>ANT 8 external antenna</p> <ul style="list-style-type: none"> Without antenna connecting cable For RF250R and RF350M readers. 	6GT2398-1CF00
<ul style="list-style-type: none"> With antenna connecting cable. The antenna connecting cable is included in the scope of delivery of the antenna and can be connected at both ends (M8 connector straight / M8 angled). Length 3 m. For RF250R readers. 	6GT2398-1CF10
Accessories	
<p>Antenna connecting cable for ANT 3 / ANT 3S / ANT 8</p> <p>For direct connection of ANT 3, ANT 3S and ANT 8 to RF350M (6GT2803-1BA10).</p> <ul style="list-style-type: none"> Length 0.1 m 	6GT2898-0EA00
 <ul style="list-style-type: none"> Length 3 m 	6GT2391-0AH30

Dimensional drawings

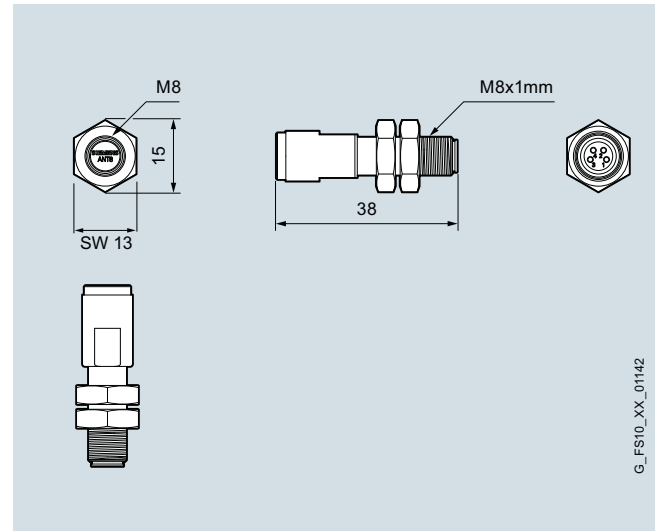

ANT 8 antenna

RFID systems for the HF range

HF antennas

ANT 12 for RF250R, RF350R and RF350M

Overview

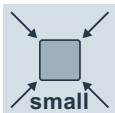

The ANT 12 antenna is a universal round antenna in M12 design for assembly lines with extremely small workpiece holders. Dimensions $\varnothing \times L$ (mm): M12 x 40.

Technical specifications

Article number	6GT2398-1CC00
Product type designation	ANT 12 antenna
Suitability for operation	RF250R / RF350R / RF350M / MOBY E
Wireless frequencies	
Transmission frequency Rated value	13.56 MHz
Electrical data	
Type of electrical connection of the antenna	M8, 4-pin
Design of plug-in connection	male
Mechanical data	
Material	Crastin
Color	Pastel turquoise
Tightening torque of the screw for securing the equipment maximum	3 Nm
Mounting distance	0 m
• relating to metal surfaces recommended minimum	

Article number	6GT2398-1CC00
Product type designation	ANT 12 antenna
Permitted ambient conditions	
Ambient temperature	
• during operation	-25 ... +70 °C
• during storage	-40 ... +85 °C
• during transport	-40 ... +85 °C
Protection class IP	IP67, front
Shock resistance	according to EN 60721-3-7 Class 7M2
Shock acceleration	500 m/s ²
Vibrational acceleration	200 m/s ²
Design, dimensions and weight	
Depth	40 mm
Diameter	12 mm
Net weight	145 g
Mounting type	2 plastic cscrew nuts M12 x 1.0
Cable length of antenna cable	3 m
Standards, specifications, approvals	
Certificate of suitability	CE, FCC, IC, cULus, Ex approval only together with RF350R reader 6GT2801-4AB10

Selection and ordering data

	Article No.
ANT 12 external antenna for readers RF250R, RF350R and RF350M.	6GT2398-1CC00

Dimensional drawings

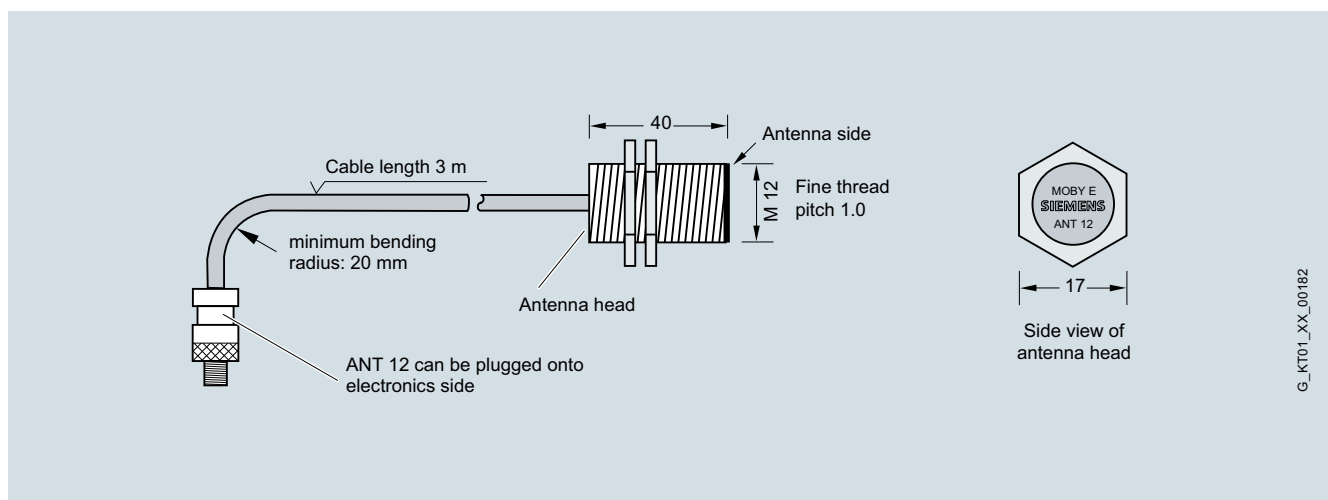

ANT 12 antenna

g_KT01_XX_00182

Overview

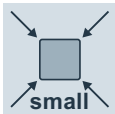

The ANT 18 antenna is a universal round antenna in M18 design for assembly lines with small workpiece holders. Dimensions $\varnothing \times L$ (mm): M18 x 55.

Article number	6GT2398-1CA00
Product type designation	ANT 18 antenna
Permitted ambient conditions	
Ambient temperature	
• during operation	-25 ... +70 °C
• during storage	-40 ... +85 °C
• during transport	-40 ... +85 °C
Protection class IP	IP67, front
Shock resistance	according to EN 60721-3-7 Class 7M2
Shock acceleration	500 m/s ²
Vibrational acceleration	200 m/s ²
Design, dimensions and weight	
Depth	55 mm
Diameter	18 mm
Net weight	130 g
Mounting type	2 plastic cscrew nuts M18 x 1.0
Cable length of antenna cable	3 m
Standards, specifications, approvals	
Certificate of suitability	CE, FCC, IC, cULus, Ex approval only together with RF350R reader 6GT2801-4AB10

Technical specifications

Article number	6GT2398-1CA00
Product type designation	ANT 18 antenna
Suitability for operation	RF250R / RF350R / RF350M / MOBY E
Wireless frequencies	
Transmission frequency Rated value	13.56 MHz
Electrical data	
Type of electrical connection of the antenna	M8, 4-pin
Design of plug-in connection	male
Mechanical data	
Material	Crastin
Color	Pastel turquoise
Tightening torque of the screw for securing the equipment maximum	3 Nm
Mounting distance	
• relating to metal surfaces recommended minimum	0 mm

Selection and ordering data

	Article No.
ANT 18 external antenna for readers RF250R, RF350R and RF350M.	6GT2398-1CA00

Dimensional drawings

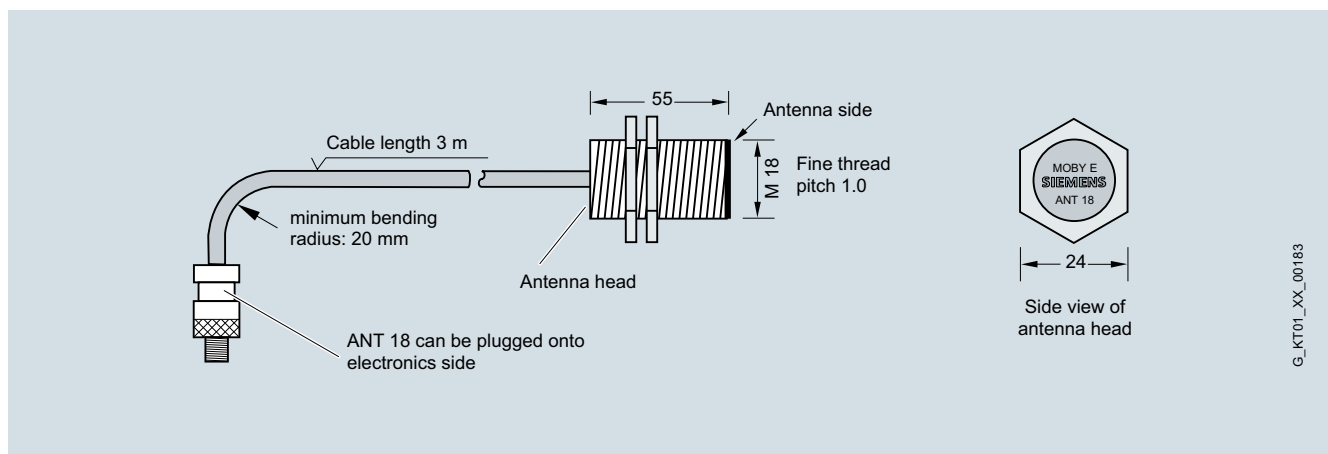

ANT 18 antenna

RFID systems for the HF range

HF antennas

ANT 30 for RF250R, RF350R and RF350M

Overview



The ANT 30 antenna is a universal round antenna in M30 design for assembly lines with small workpiece holders.
Dimensions $\varnothing \times L$ (mm): M30 x 58

Technical specifications

Article number	6GT2398-1CD00
Product type designation	ANT 30 antenna
Suitability for operation	RF250R / RF350R / RF350M / MOBY E
Wireless frequencies	
Transmission frequency Rated value	13.56 MHz
Electrical data	
Type of electrical connection of the antenna	M8, 4-pin
Design of plug-in connection	male
Mechanical data	
Material	Crastin
Color	Pastel turquoise
Tightening torque of the screw for securing the equipment maximum	3 Nm
Mounting distance	
• relating to metal surfaces recommended minimum	0 m

Article number	6GT2398-1CD00
Product type designation	ANT 30 antenna
Permitted ambient conditions	
Ambient temperature	
• during operation	-25 ... +70 °C
• during storage	-40 ... +85 °C
• during transport	-40 ... +85 °C
Protection class IP	IP67, front
Shock resistance	according to EN 60721-3-7 Class 7M2
Shock acceleration	500 m/s ²
Vibrational acceleration	200 m/s ²
Design, dimensions and weight	
Depth	58 mm
Diameter	30 mm
Net weight	180 g
Mounting type	2 plastic csrew nuts M30 x 1.5
Cable length of antenna cable	3 m
Standards, specifications, approvals	
Certificate of suitability	CE, FCC, IC, cULus, Ex approval only together with RF350R reader 6GT2801-4AB10

Selection and ordering data

	Article No.
ANT 30 external antenna for readers RF250R, RF350R and RF350M.	6GT2398-1CD00

Dimensional drawings

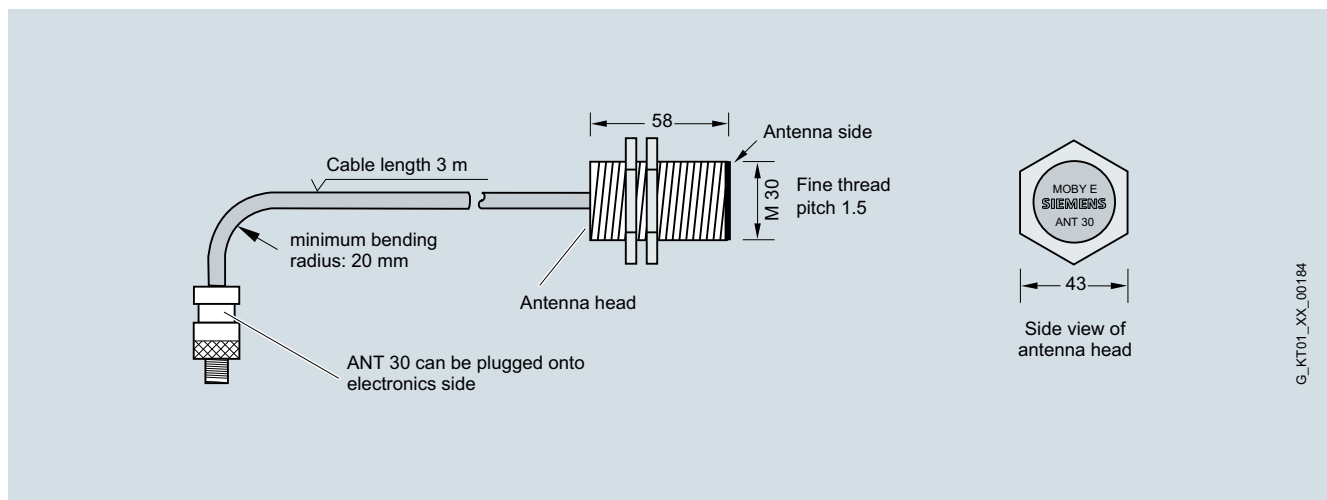

ANT 30 antenna

G_KT01_XX_00184

Overview

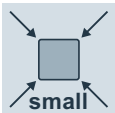

The ANT D1 is a universal antenna for the areas of production and logistics that can also be used in dynamic applications. The high degree of protection (IP67) means the antenna can also be used under harsh industrial conditions.

Selection and ordering data

	Article No.
ANT D1 antenna For RF290R readers, including antenna cable, PVC, length 3.3 m	6GT2698-5AC00
Accessories	
Cable extension Length 7.2 m	6GT2691-0DH72

Dimensional drawings

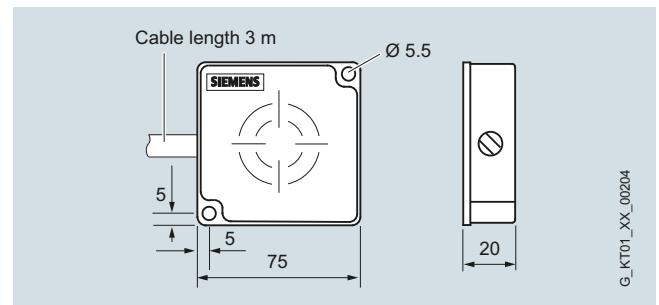

ANT D1 antenna

Technical specifications

Article number	6GT2698-5AC00
Product type designation	ANT D1 antenna
Suitability for operation	RF290R
Wireless frequencies	
Transmission frequency Rated value	13.56 MHz
Electrical data	
Type of electrical connection of the antenna	1-pol. TNC-Stecker
Design of plug-in connection	female
Mechanical data	
Material	PA 12
Color	Anthracite
Mounting distance	
• relating to metal surfaces recommended minimum	0.02 m
Permitted ambient conditions	
Ambient temperature	
• during operation	-20 ... +55 °C
• during storage	-25 ... +70 °C
• during transport	-25 ... +70 °C
Protection class IP	IP67
Shock resistance	according to EN 60721-3-7 Class 7M2
Shock acceleration	500 m/s ²
Vibrational acceleration	200 m/s ²
Design, dimensions and weight	
Width	75 mm
Height	75 mm
Depth	20 mm
Net weight	270 g
Mounting type	2 screws M5
Cable length of antenna cable	3.3 m
Accessories	Antenna cable

RFID systems for the HF range

HF antennas

ANT D2 for SLG D11 / SLG D11S

Overview



The ANT D2 antenna is designed for transponders that are directed sideways past the antenna. This antenna is specially designed for high speeds with a small antenna size, e.g. in overhead conveyors, assembly lines, production and order picking. It can be mounted directly onto metal surfaces.

Technical specifications

Article number	6GT2698-5BB00
Product type designation	ANT D2 antenna
Suitability for operation	MOBY D with SLG D11
Wireless frequencies	
Transmission frequency Rated value	13.56 MHz
Electrical data	
Type of electrical connection of the antenna	1-pol. TNC-Stecker
Design of plug-in connection	female
Mechanical data	
Material	PA 12
Color	Anthracite
Tightening torque of the screw for securing the equipment maximum	2 Nm
Mounting distance	
• relating to metal surfaces recommended minimum	0 m
Permitted ambient conditions	
Ambient temperature	
• during operation	-25 ... +70 °C
• during storage	-40 ... +85 °C
• during transport	-40 ... +85 °C
Protection class IP	IP65
Shock resistance	according to EN 60721-3-7 Class 7M2
Shock acceleration	500 m/s ²
Vibrational acceleration	100 m/s ²
Design, dimensions and weight	
Width	75 mm
Height	75 mm
Depth	40 mm
Net weight	260 g
Mounting type	2 screws M5, mounting dependent on direction
Cable length of antenna cable	3.3 m
Standards, specifications, approvals	
Certificate of suitability	CE, FCC, IC, cULus

Selection and ordering data

	Article No.
ANT D2 antenna	6GT2698-5BB00
For SLG D11 / SLG D11S basic units, lateral antenna field, incl. PVC antenna cable (length 3.3 m).	

Dimensional drawings

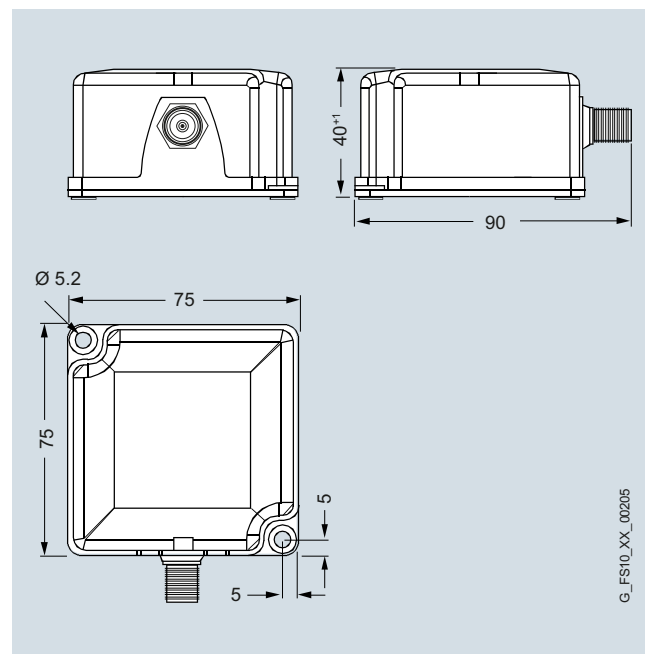

ANT D2 antenna

G_FS10_XX_00205

Overview

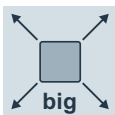

The ANT D5 is a universal antenna designed for warehouse, logistics and distribution applications. The high degree of protection (IP65) enables the antenna to be used under harsh industrial conditions. The antenna is designed for transponders that are directed sideways past the antenna.

Technical specifications

Article number	6GT2698-5AA10
Product type designation	ANT D5 antenna
Suitability for operation	RF290R, MOBY D with SLG D10, D11
Wireless frequencies	
Transmission frequency Rated value	13.56 MHz
Electrical data	
Type of electrical connection of the antenna	1-pol. TNC-Stecker
Design of plug-in connection	female
Mechanical data	
Material	Aluminum/plastic
Color	black/gray
Mounting distance	
• relating to metal surfaces recommended minimum	0 m
Permitted ambient conditions	
Ambient temperature	
• during operation	-20 ... +55 °C
• during storage	-25 ... +70 °C
• during transport	-25 ... +70 °C
Protection class IP	IP65
Shock resistance	according to EN 60721-3-7 Class 7M2
Shock acceleration	300 m/s ²
Vibrational acceleration	10 m/s ²

Article number	6GT2698-5AA10
Product type designation	ANT D5 antenna
Design, dimensions and weight	
Width	380 mm
Height	380 mm
Depth	110 mm
Net weight	2 kg
Mounting type	4 screws M6
Cable length of antenna cable	3.3 m
Standards, specifications, approvals	
Certificate of suitability	CE, FCC
Accessories	
	Antenna cables 3.3 m, 10 m, extension 7.2 m

Selection and ordering data

	Article No.
ANT D5 antenna for RF290R readers and SLG D11 / SLG D11S basic units, including antenna cable, PVC, length 3.3 m	6GT2698-5AA10
Accessories	
Antenna switch For connecting several antennas (ANT D5 or ANT D6) to one RF290R reader, IP65, -25 °C to +65 °C	6GT2690-0AC00
	
SIMATIC RF260X antenna multiplexer Antenna multiplexer for RF290R reader when connected via RS232. 6 x antenna outputs (for ANT D5, ANT D6 and ANT D10); IP65; 240 mm x 150 mm x 70 mm; including antenna connecting cable, cable length 0.4 m.	6GT2894-0EA00
	
Accessories for antenna switch and antenna multiplexer	
Antenna connecting cable Between antenna and reader or antenna switch/multiplexer, PVC material.	
• Length 3.3 m	6GT2691-0CH33
• Length 10 m	6GT2691-0CN10
Extension cable For 6GT2691-0CH33, PVC material. Length 7.2 m.	6GT2691-0DH72

RFID systems for the HF range

HF antennas

ANT D5 for RF290R and SLG D11 / D11S

Dimensional drawings

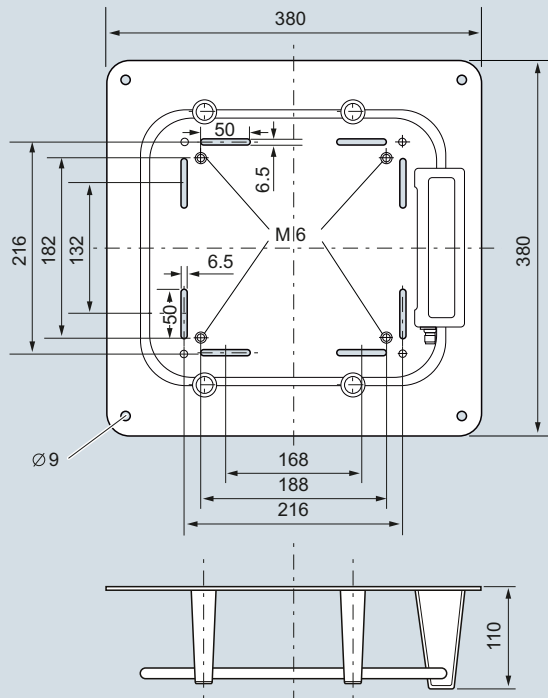

G_FS10_XX_00431

ANT D5 antenna

2

Overview

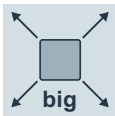

The ANT D6 is a universal antenna designed for warehouse, logistics and distribution applications. The high degree of protection (IP65) enables the antenna to be used under harsh industrial conditions.

Technical specifications

Article number	6GT2698-5AB00
Product type designation	ANT D6 antenna
Suitability for operation	RF290R, MOBY D with SLG D10
Wireless frequencies	
Transmission frequency Rated value	13.56 MHz
Electrical data	
Type of electrical connection of the antenna	1-pol. TNC-Stecker
Design of plug-in connection	female
Mechanical data	
Material	Aluminum/plastic
Color	gray / black
Mounting distance	
• relating to metal surfaces recommended minimum	0 m
Permitted ambient conditions	
Ambient temperature	
• during operation	-20 ... +55 °C
• during storage	-25 ... +70 °C
• during transport	-25 ... +70 °C
Protection class IP	IP65
Shock resistance	according to EN 60721-3-7 Class 7M2
Shock acceleration	300 m/s ²
Vibrational acceleration	10 m/s ²
Design, dimensions and weight	
Width	480 mm
Height	580 mm
Depth	110 mm
Net weight	3.3 kg
Mounting type	4 screws M6
Cable length of antenna cable	3.3 m
Standards, specifications, approvals	
Certificate of suitability	CE, FCC, cULus
Accessories	
Accessories	Antenna cables 3.3 m, 10 m, extension 7.2 m

Selection and ordering data

	Article No.
ANT D6 antenna for RF290R readers, including antenna cable, PVC, length 3.3 m	6GT2698-5AB00
Accessories	
Shrouding cover Serves as contact protection for ANT D6	6GT2690-0AD00
Antenna switch For connecting several antennas (ANT D5 or ANT D6) to one RF290R reader, IP65, -25 °C to +65 °C	6GT2690-0AC00
	
SIMATIC RF260X antenna multiplexer Antenna multiplexer for RF290R reader when connected via RS232. 6 x antenna outputs (for ANT D5, ANT D6 and ANT D10); IP65; 240 mm x 150 mm x 70 mm; including antenna connecting cable, cable length 0.4 m.	6GT2894-0EA00
	
Accessories for antenna switch and antenna multiplexer	
Antenna connecting cable Between antenna and reader or antenna switch/multiplexer, PVC material.	
• Length 3.3 m	6GT2691-0CH33
• Length 10 m	6GT2691-0CN10
Extension cable For 6GT2691-0CH33, PVC material. Length 7.2 m.	6GT2691-0DH72

RFID systems for the HF range

HF antennas

ANT D6 for RF290R

Dimensional drawings

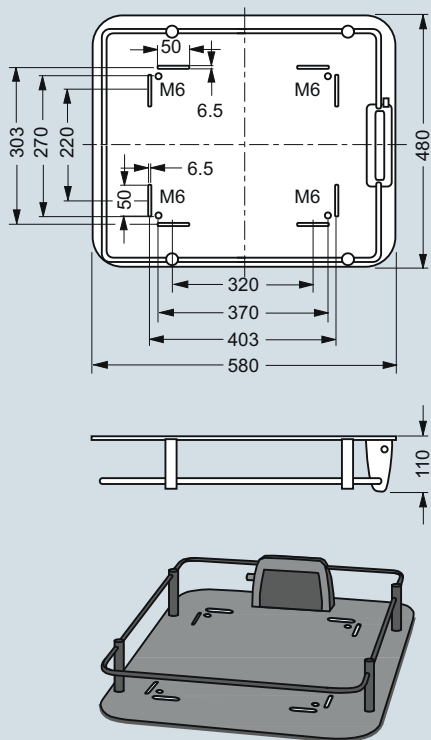

G_FS10_XX_00239

ANT D6 antenna

Overview

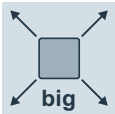

The ANT D10 is a universal antenna designed for warehouse, logistics and distribution applications. The high degree of protection (IP65) enables the antenna to be used under harsh industrial conditions.

Technical specifications



Article number	6GT2698-5AF00
Product type designation	ANT D10 antenna
Suitability for operation	RF290R, MOBY D with SLG D10
Wireless frequencies	
Transmission frequency Rated value	13.56 MHz
Electrical data	
Type of electrical connection of the antenna	1-pol. TNC-Stecker
Design of plug-in connection	female
Mechanical data	
Material	Aluminum/plastic
Color	Transparent (cover), gray/black (antenna)
Mounting distance	
• relating to metal surfaces recommended minimum	0 m
Permitted ambient conditions	
Ambient temperature	
• during operation	-20 ... +55 °C
• during storage	-25 ... +70 °C
• during transport	-25 ... +70 °C
Protection class IP	IP65
Shock resistance	according to EN 60721-3-7 Class 7M2
Shock acceleration	300 m/s ²
Vibrational acceleration	10 m/s ²
Design, dimensions and weight	
Width	365 mm
Height	1 150 mm
Depth	115 mm
Net weight	10 kg
Mounting type	4 screws M6
Cable length of antenna cable	3.3 m
Standards, specifications, approvals	
Certificate of suitability	CE, FCC, cULus
Accessories	
Accessories	Antenna cables 3.3 m, 10 m, extension 7.2 m

RFID systems for the HF range

HF antennas

ANT D10 for RF290R

Selection and ordering data

	Article No.
ANT D10 antenna For the RF290R reader, incl. antenna cable, PVC, length 3.3 m.	6GT2698-5AF00
<i>Accessories</i>	
Antenna switch For connecting multiple antennas (ANT D5, ANT D6 or ANT D10) to one reader	6GT2690-0AC00
	
SIMATIC RF260X antenna multiplexer Antenna multiplexer for RF290R reader when connected via RS232. 6 x antenna outputs (for ANT D5, ANT D6 and ANT D10); IP65; 240 mm x 150 mm x 70 mm; including antenna connecting cable, cable length 0.4 m	6GT2894-0EA00
	
<i>Accessories for antenna switch and antenna multiplexer</i>	
Antenna connecting cable Between antenna and reader or antenna switch/multiplexer, PVC material.	
<ul style="list-style-type: none"> Length 3.3 m 	6GT2691-0CH33
<ul style="list-style-type: none"> Length 10 m 	6GT2691-0CN10
Extension cable For 6GT2691-0CH33, PVC material. Length 7.2 m.	6GT2691-0DH72

Dimensional drawings

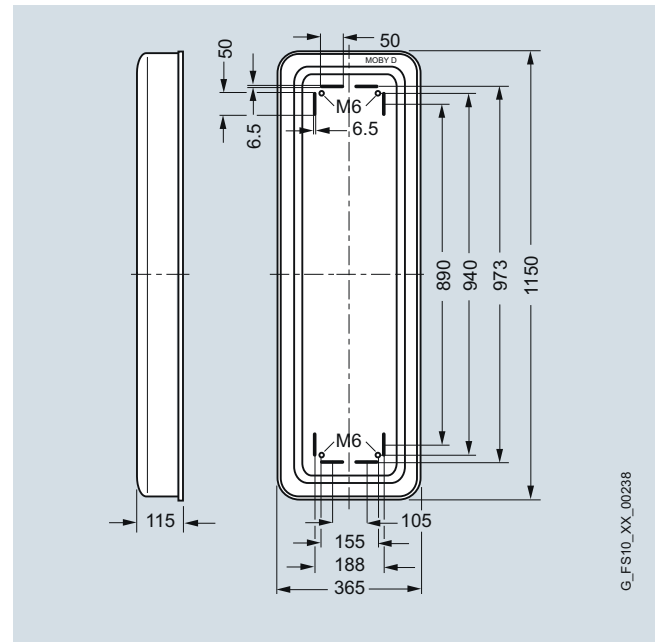

ANT D10 antenna

G_FS10_XX_00238

RFID systems for the UHF range



3/2	RF600
3/4	<u>RF600 transponders</u>
3/5	RF622L
3/6	RF630L
3/9	RF640L
3/11	RF680L
3/12	RF690L
3/14	RF610T
3/16	RF620T
3/18	RF622T
3/20	RF625T
3/22	RF630T
3/24	RF640T
3/26	RF680T
3/28	<u>RF600 readers</u>
3/29	Web-based interface
3/30	RF650R
3/33	RF680R
3/37	RF685R
3/41	RF650M mobile handheld terminal
3/44	<u>RF600 antennas</u>
3/45	RF620A
3/48	RF640A, RF642A
3/51	RF660A

RFID systems for the UHF range

SIMATIC RF600

Introduction

Overview



Identification tasks in the UHF range (865 to 868 MHz, 902 to 928 MHz, and 920 to 925 MHz) that demand a wide range of several meters are implemented with SIMATIC RF600. The system is suitable for storing and recording a unique identification according to the EPCglobal standard (Electronic Product Code) on products, containers or transport units. Storage of additional, freely-definable user data is also possible.

Various data carriers - from low-cost SmartLabels through to heat-resistant transponders that can be used for several thousand cycles - are available for industrial applications.

SIMATIC RF600 can be used with SIMATIC controllers and PC/IT systems.

Benefits

get Designed for Industry

SIMATIC RF600 has been specially developed for the requirements of industry. It enables economical and reliable use of RFID in production, materials management and logistics.

- Cost savings and improvement in process quality through application of UHF RFID with maximum reliability in the industrial environment:
 - Application of a uniform RFID system throughout the entire production process and supplier chain as a result of inexpensive transponders and wide ranges (no technology gaps).
 - Maximum availability even in applications with a complex radio environment such as high reader density, strongly reflecting metal environments, dynamic surroundings.
 - Permanent RFID identification of products thanks to disposable transponders matched to the application, e.g. heat-resistant, high degree of protection.
 - Wide transponder portfolio and customized versions for cost-optimized use.
- Flexibility due to compact designs and remote antennas.
- Safe and selective individual acquisition or bulk identification is possible.
- High reading speed: Even fast-moving transponders are reliably detected.

- Simplified engineering, commissioning, diagnostics and maintenance through seamless integration into Totally Integrated Automation (TIA):
 - Integrated bus connection to an automation system, such as SIMATIC, SIMOTION or SINUMERIK via communication modules with PROFIBUS and PROFINET.
 - Direct interfacing to IT systems via Ethernet.
 - Integrated processing logic allows data preprocessing in the reader and saves costs for external PCs, software modules, etc.
 - Simple S7 software integration via ready-to-use function blocks.
 - Extensive diagnostic functions.
- High degree of investment protection thanks to
 - Open standards EPCglobal Class 1 Gen 2 / ISO 18000-6C or ISO 18000-6B.
 - Software compatibility between the RFID systems of Siemens.
 - Standardized communication interfaces.
 - Openness through connection possibilities to various bus systems from different manufacturers and PC environments via communication modules.
- Worldwide service and support.
 - Tried and tested in numerous customer projects.

Application

SIMATIC RF600 is used for the contactless identification of every kind of object, e.g. transport containers, pallets, production goods, or it can be used generally for recording goods in bulk. As a rule, these applications are open loops in which passive SmartLabels on goods, products, bulk containers or transport units are used. In this case, the system distinguishes itself due to its high reading speeds, large data transmission rates and the fact that it can handle long reading distances.

In addition, the system is suitable for reading and writing reusable transponders that are used in closed loops.

Typical applications include:

- Acquisition of deliveries in the incoming goods / outgoing goods departments.
- Identification of transport containers, barrels or containers at important stations in the process; creation of a "Container passport" for automatic creation of a usage history.
- Control of material flow and production in multi-variant, order-related production.
- Labeling of products under severe ambient conditions, e.g. dust, dirt, high temperatures.
- Stock monitoring and usage monitoring of tools and devices.
- Automation of warehouses and distribution centers with industrial trucks.

Design

The SIMATIC RF600 readers are available as variants with an integral antenna (RF685R) and with connection options for external antennas (RF650R, RF680R).

For quick and easy cabling, pre-assembled cables are available in various lengths.

Multicolored LEDs indicate the status of reader and transponder.

The high IP65 degree of protection of the reader enables it to be used in harsh industrial environments.

The SIMATIC RF600 series of transponders are used as mobile data carriers.

Transponders suitable for a wide variety of different requirements can be selected from an extensive range: For example, low-cost, heat-resistant SmartLabels for temperatures up to 230 °C, in rugged credit card format, or screw-fit transponders that can be attached by robots.

The transponders are attached to the object to be identified, e.g. by means of screws, adhesive or pre-assembled spacer.

Function

All SIMATIC RF600 readers are suitable for reliable writing and reading tasks in the UHF range from 865 to 868 MHz (ETSI), 902 to 928 MHz (FCC), and 920 to 925 MHz (CMIIT), with very large ranges up to 8 m.

The SIMATIC RF680R/685R readers are particularly suitable for use in production environments where a high protection class and integration into SIMATIC controllers are required. These two new readers also offer an extensive toolset for commissioning and diagnostics.

User-friendly function blocks simplify programming in Step 7 or the TIA Portal. Special functions are available in areas hostile to wireless communication encountered in production environments, such as reflections and dead zones resulting from metal or superimposed radio fields due to a high reader density.

In this manner, process stability is substantially increased by automatic adaptation of the transmit power and intelligent filtering of the reading results. The multi-stage filter concept ensures that, based on the wireless properties, the correct transponder within the RF field of the reader is always processed. The appropriate data storage medium is automatically selected on the basis of various indicators, such as the evaluation of the RSSI value (Received Signal Strength Indicator), the reading frequency, or the transmit power required.

Transponders that have already been processed can be stored in a "blacklist" in the reader and thus filtered out. Various mechanisms can be activated according to requirements.

One special feature of the RF685R is the integrated adaptive antenna. Whether linear (horizontal/vertical), circular or automatic polarization, the integrated antenna of the RF685R achieves the best reading rates, even in difficult radio reception environments.

The RF650R and RF680R/685R readers can be set and diagnosed by means of a Web browser. The RF680R/685R can also optionally be commissioned and diagnosed in the TIA Portal.

The RF650R reader is used mainly in logistics applications where a high degree of protection and SIMATIC integration are of lesser importance. With its four external antenna connections, as many as four individual reading stations or large gate applications can be implemented. The integrated processing logic allows comprehensive filter functions and control of the digital inputs/outputs in the reader itself. Configuration, commissioning and diagnostics are easily possible by means of a web browser, without the need for installing additional software.

External sensor technology (e.g. light barriers or motion detectors) and indicator lamps or acoustic sensors are integrated by means of the four digital inputs and outputs.

Integration

A wide range of communication modules, function blocks, as well as high-performance drivers and function libraries enable easy and quick integration into user applications.

In PC/IT environments, the RF650R, RF680R and RF685R devices can be integrated by means of a simple XML protocol. Programming examples are available for this purpose.

Because the RF680R and RF685R readers are part of Totally Integrated Automation (TIA), integration into automation systems such as SIMATIC S7 is Plug & Play. The device information is contained as standard in the TIA Portal as from V13 SP1, in the same way as the easy-to-operate Identification Profile function blocks.

SIMATIC Ident Configuration Guide

Here is a compact configuration tool for setting up RFID systems:

<http://support.automation.siemens.com/WW/view/en/67384964>

Technical specifications

RFID system	SIMATIC RF600
Transmission frequency	865 ... 868 MHz (ETSI) 902 ... 928 MHz (FCC) 920 ... 925 MHz (CMIIT)
Range	Max. 8 m
Protocol (air interface)	<ul style="list-style-type: none"> EPCglobal Class 1 Gen 2 ISO 18000-6B ISO 18000-6C
Approvals	<ul style="list-style-type: none"> ETSI EN 302208, CE FCC UL CMIIT
Memory capacity	Max. 496 bits EPC, 3 424 bytes user memory
Data transfer rate for wireless transmission	Max. 300 kbps
Multitag/Bulk capability	Yes
Special features	<ul style="list-style-type: none"> SIMATIC or PC/IT integration Configurable data processing in the readers Special antennas for industrial applications Powerful diagnostics functions

RFID systems for the UHF range









SIMATIC RF600 transponders



Introduction

Overview

SIMATIC RF600 offers a variety of transponders for numerous applications. All transponders are designed to be passive and maintenance-free and thus ensure problem-free operation.

The transponders support the EPCglobal Class 1, Gen 2 / ISO 18000-6C standard, and can be used with all SIMATIC RF600 readers.

Transponder	Features	Page
RF622L 	Large memory UHF SmartLabel with 4 KB FRAM.	3/5
RF630L 	SmartLabel based on UHF Class 1 Gen 2 technology. This SmartLabel is available in several versions.	3/6
RF640L 	The SIMATIC RF640L (on-metal label) is designed for direct mounting on metal surfaces and has a read range of up to 4 m.	3/9
RF680L 	Heat-resistant UHF SmartLabel for identifying objects with high temperature requirements.	3/11
RF690L 	Heat-resistant UHF SmartLabel for mounting directly on metal.	3/12
RF610T 	A flexible card in ISO format that is suitable for a wide variety of applications, e.g. for identification of containers, pallets, or vessels. The SIMATIC RF610T can be attached to the most diverse materials, including plastic, wood, glass and metal (with spacer).	3/14
RF620T 	The RF620T container transponder is suitable for identifying transport containers or pallets. It can be attached to metal if spacers are used.	3/16
RF622T 	Large memory RF622T transponder with large 4 KB FRAM memory enables the storage of larger volumes of data. It is therefore especially suited to use in distributed configurations. If spacers are used, the RF622T can also be mounted on metal surfaces.	3/18
RF625T 	The RF625T disk transponder is suitable for use in industrial environments, such as in the equipping of tools, machines and plants.	3/20

Transponder	Features	Page
RF630T 	The RF630T screw transponder (M6) is particularly suitable for controlling and monitoring production processes.	3/22
RF640T 	The RF640T tool transponder can be mounted directly on metal, and is therefore particularly suitable for tracking tools, containers and metallic equipment.	3/24
RF680T 	High-temperature transponder up to 220 °C and high degree of protection IP68/IPx9K. It is suitable for industrial applications with high thermal stress.	3/26

Benefits

get Designed for Industry

The comprehensive portfolio of SIMATIC RF600 transponders with long ranges according to EPCglobal standard offers the appropriate solution for every requirement in logistics and production:

- Low-cost SmartLabels and transponders.
- Heat-resistant SmartLabels and transponders for high temperature ranges up to 230 °C for use in paint shops.
- Screw-fit transponders for automatic attachment by robots.
- Screw-fit transponders for flush-mounting in metal for identifying workpieces or workpiece holders.
- Rugged transponders with high resistance to environmental influences.
- Customized solutions for SmartLabels and transponders on request.

Technical specifications

Field data (operating/limit distance) of transponders and readers (all specifications in mm)

The field data of the RF600 UHF transponders in connection with RF600 readers is listed in the technical specifications of the RFID overview.

The listed technical data are typical values and are valid at operating temperature.

Overview

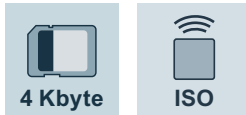

With a capacity of 4 KB FRAM, of which 3 424 bytes are available as user memory, the new RF622L UHF RFID SmartLabel enables larger volumes of data to be stored on tagged objects, as well as facilitating rapid access to them.

The large memory label offers a considerable reading range of up to 3 meters on non-metallic surfaces.

The RF622L SmartLabel is suitable for the permanent marking of products and can be individually printed from the roll, for example with plain text or additional optical codes.

Industrial plant management, RFID identification of tools, containers and non-metallic equipment. Suitable for a host of uses in a wide range of applications, e.g. logistics.

Technical specifications

Article number	6GT2810-4AC80
Product type designation	RF622L transponder
Suitability for operation	RF600
Wireless frequencies	
Operating frequency	860 ... 960 MHz
Electrical data	
Range maximum	3 m; observe system manual RF600: overrange is possible, range is reader dependent: observe
http://support.automation.siemens.com/WW/view/en/67384964	
Protocol with radio transmission	EPCglobal Class 1 Gen 2 / ISO 18000-6C
Transfer rate with radio transmission maximum	320 kbit/s
Product feature multitag-capable	Yes
Polarization	Linear
Product component Backup battery	No

Article number	6GT2810-4AC80
Product type designation	RF622L transponder
Suitability for operation	RF600
Memory	
Type of memory	FRAM
Storage capacity of the user memory	3 424 byte
Type of memory organization	EPC memory 496 bits, user memory 3 424 bytes, TID memory 32 bytes
Number of read cycles at ambient temperature < 40 °C maximum	10 000 000 000
Number of write cycles at ambient temperature < 40 °C maximum	10 000 000 000
Data retention time at ambient temperature < 40 °C not less than	10 y
Property of memory	lock, unlock, write protection, password protection
Type of transponder chip used	Fujitsu MB97R803
Mechanical data	
Material	PET
Color	white
Mounting distance relating to metal surfaces recommended minimum	5 mm
Permitted ambient conditions	
Ambient temperature	
• during read/write access	-20 ... +85 °C
• outside the read/write area	-40 ... +85 °C
• during storage	13 ... 23 °C
Protection class IP	IP64, in glued condition
Resistance to mechanical stress	Torsion and bending stress conditionally permissible
Design, dimensions and weight	
Width	90 mm
Height	0.5 mm
Depth	18 mm
Net weight	1 g
Mounting type	one-side adhesive
Product properties, functions, components general	
Product feature	
• silicon-free	Yes
• printable	Yes
Printing process	Thermal transfer process

Selection and ordering data

	Article No.
SIMATIC RF622L SmartLabel	6GT2810-2AC80
Frequency: 860 to 960 MHz, EPC: 496 bits, user memory: 3 424 bytes	
Plastic, self-adhesive, dimensions (mm): 90 x 18 x 0.5, order quantity 500 units (supplied on rolls) or a multiple thereof.	

RFID systems for the UHF range

SIMATIC RF600 transponders

RF630L

Overview

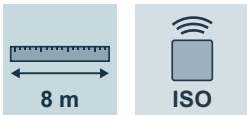

6GT2810-2AB00

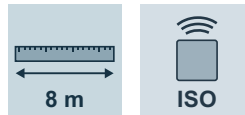
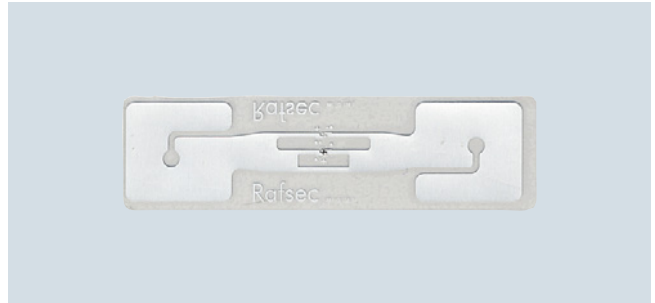

6GT2810-2AB02-0AX0

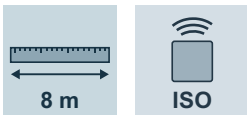

6GT2810-2AB01

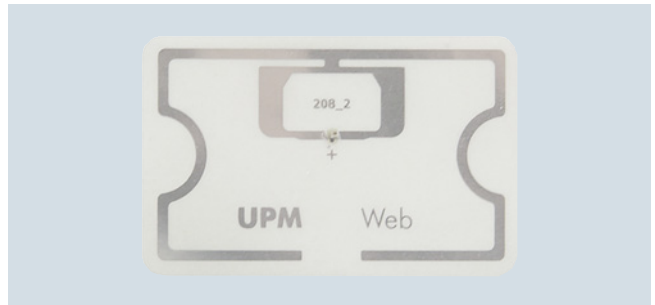

6GT2810-2AB03

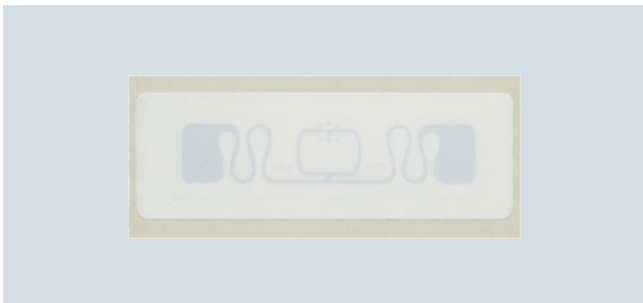

6GT2810-2AE81-0AX1

The SIMATIC RF630L SmartLabels are suitable for (permanent) identification of products or shipping units with the Electronic Product Code (EPC) as well as with other user data. Thanks to its broadband design, the SIMATIC RF630L SmartLabel can be used in numerous countries.

Technical specifications

Article number	6GT2810-2AB00	6GT2810-2AB01	6GT2810-2AE81-0AX1	6GT2810-2AB02-0AX0	6GT2810-2AB03
Product type designation	RF630L transponder	RF630L transponder	RF630L transponder	RF630L transponder	RF630L transponder
Suitability for operation	RF600	RF600	RF600	RF600	RF600
Wireless frequencies					
Operating frequency	860 ... 960 MHz	860 ... 960 MHz	860 ... 960 MHz	860 ... 960 MHz	860 ... 960 MHz
Electrical data					
Range maximum	8 m; observe system manual RF600: overrange is possible, range is reader dependent: observe	8 m; observe system manual RF600: overrange is possible, range is reader dependent: observe	4 m; observe system manual RF600: overrange is possible, range is reader dependent: observe	8 m; observe system manual RF600: overrange is possible, range is reader dependent: observe	5 m; observe system manual RF600: overrange is possible, range is reader dependent: observe
	http://support.automation.siemens.com/WW/view/en/67384964				
Protocol with radio transmission	EPCglobal Class 1 Gen 2 / ISO 18000-6C	EPCglobal Class 1 Gen 2 / ISO 18000-6C	EPCglobal Class 1 Gen 2 / ISO 18000-6C	EPCglobal Class 1 Gen 2 / ISO 18000-6C	EPCglobal Class 1 Gen 2 / ISO 18000-6C
Transfer rate with radio transmission maximum	320 kbit/s	320 kbit/s	320 kbit/s	320 kbit/s	320 kbit/s
Product feature multitag-capable	Yes	Yes	Yes	Yes	Yes
Polarization	Linear	Linear	Linear	Linear	Linear
Product component Backup battery	No	No	No	No	No
Memory					
Type of memory	EEPROM	EEPROM	EEPROM	EEPROM	EEPROM
Storage capacity of the user memory	12 byte	12 byte	16 byte	64 byte	64 byte
Type of memory organization	EPC memory 96 bits, TID memory 4 bytes	EPC memory 96 bits, TID memory 4 bytes	EPC memory 128 bits, TID memory 8 bytes	EPC memory 96/128 bits, user memory 64 bytes (512 bits), TID memory 4 bytes	EPC memory 96/240 bits, user memory 64 bytes (512 bits), TID memory 8 bytes
Number of read cycles at ambient temperature < 40 °C maximum	100 000 000 000 000	100 000 000 000 000	100 000 000 000 000	100 000 000 000 000	100 000 000 000 000
Number of write cycles at ambient temperature < 40 °C maximum	100 000	100 000	100 000	100 000	100 000
Data retention time at ambient temperature < 40 °C not less than	10 y	10 y	30 y	10 y	10 y
Property of memory	lock, unlock, kill, write protection, password protection	lock, unlock, kill, write protection, password protection	lock, unlock, kill, write protection, password protection	lock, unlock, kill, write protection, password protection	lock, unlock, kill, write protection, password protection
Type of transponder chip used	IMPINJ MONZA 2	IMPINJ MONZA 2	NXP G2iL	IMPINJ MONZA 4QT	NXP G2XM
Mechanical data					
Material	Paper	Paper	PET	PET	PET
Color	white	white	white	transparent	transparent
Mounting distance relating to metal surfaces recommended minimum	3 mm	3 mm	3 mm	3 mm	3 mm
Permitted ambient conditions					
Ambient temperature					
• during read/write access	-40 ... +65 °C	-40 ... +65 °C	-25 ... +85 °C	-40 ... +65 °C	-40 ... +65 °C
• outside the read/write area	-40 ... +80 °C	-40 ... +80 °C	-40 ... +160 °C	-40 ... +80 °C	-40 ... +80 °C
• during storage	15 ... 25 °C	15 ... 25 °C	5 ... 25 °C	15 ... 25 °C	15 ... 25 °C
Ambient condition for operation	Maximum storage life 2 years at 40 to 60 % humidity, operating temperature permanent up to 65 °C, up to 80 °C for 200 cycles	Maximum storage life 2 years at 40 to 60 % humidity, operating temperature permanent up to 65 °C, up to 80 °C for 200 cycles	Maximum storage life 2 years at 45 to 55 % humidity, operating temperature permanent up to 85 °C, short term -40 °C to 160 °C for 90 minutes	Maximum storage life 2 years at 40 to 60 % humidity, operating temperature permanent up to 65 °C, up to 80 °C for 200 cycles	Maximum storage life 2 years at 40 to 60 % humidity, operating temperature permanent up to 65 °C, up to 80 °C for 200 cycles
Protection class IP	IP60, in glued condition, the label must be protected against humidity	IP60, in glued condition, the label must be protected against humidity	IP60, in glued condition, the label must be protected against humidity	IP65	IP65
Resistance to mechanical stress	Torsion and bending stress conditionally permissible	Torsion and bending stress conditionally permissible	Torsion and bending stress conditionally permissible	Torsion and bending stress conditionally permissible	Torsion and bending stress conditionally permissible

RFID systems for the UHF range

SIMATIC RF600 transponders

RF630L

Article number	6GT2810-2AB00	6GT2810-2AB01	6GT2810-2AE81-0AX1	6GT2810-2AB02-0AX0	6GT2810-2AB03
Product type designation	RF630L transponder	RF630L transponder	RF630L transponder	RF630L transponder	RF630L transponder
Suitability for operation	RF600	RF600	RF600	RF600	RF600
Design, dimensions and weight					
Width	101 mm	101 mm	30 mm	27 mm	34 mm
Height	0.3 mm	0.3 mm	0.3 mm	0.3 mm	0.3 mm
Depth	152 mm	50 mm	90 mm	97 mm	54 mm
Net weight	3 g	2 g	1 g	1 g	1 g
Mounting type	one-side adhesive onto paper / card-board	one-side adhesive onto paper / card-board	one-side adhesive	one-side adhesive onto plastic / foil	one-side adhesive onto plastic / foil
Product properties, functions, components general					
Product feature					
• printable	Yes	Yes	Yes	Yes	Yes
Printing process	Thermal transfer process	Thermal transfer process	Thermal transfer process	Thermal transfer process (currently only using Toshiba B-SX4T)	Thermal transfer process (currently only using Toshiba B-SX4T)

Selection and ordering data

	Article No.
SIMATIC RF630L SmartLabel	
Frequency 865 to 960 MHz (ETSI, FCC)	
<ul style="list-style-type: none"> Paper, adhesive on one side, 100 mm x 150 mm (4" x 6"); Ordering quantity 1 600 units (supplied on rolls) or a multiple thereof. 	6GT2810-2AB00
<ul style="list-style-type: none"> Paper, adhesive on one side, 101 mm x 50 mm (4" x 2"); Ordering quantity 1 000 units (supplied on rolls) or a multiple thereof. 	6GT2810-2AB01
<ul style="list-style-type: none"> Plastic PET, adhesive on one side, 90 mm x 30 mm (3.5" x 1.18"); Ordering quantity 7 000 units (supplied on rolls) or a multiple thereof. 	6GT2810-2AE81-0AX1
<ul style="list-style-type: none"> Plastic PET, adhesive on one side, 97 mm x 27 mm (3.8" x 1.1"); Ordering quantity 5 000 units (supplied on rolls) or a multiple thereof. 	6GT2810-2AB02-0AX0
<ul style="list-style-type: none"> Plastic PET, adhesive on one side, 54 mm x 34 mm (2.1" x 1.3"); Ordering quantity 2 000 units (supplied on rolls) or a multiple thereof. 	6GT2810-2AB03

Overview



The SIMATIC RF640L on-metal label is designed for direct mounting on metal surfaces and under these conditions achieves a read range of up to 3.5 m.

The on-metal label is suitable for applications in industrial plant management, RF identification of tools, containers and metallic equipment.

This transponder is available in two frequency versions for 865 to 868 MHz (ETSI) and 902 to 928 MHz (FCC, CMIIT).



Technical specifications

	6GT2810-2AC00	6GT2810-2AC10
Article number	6GT2810-2AC00	6GT2810-2AC10
Product type designation	RF640L transponder	RF640L transponder
Suitability for operation	RF600	RF600
Wireless frequencies		
Operating frequency	865 ... 868 MHz	902 ... 928 MHz
Electrical data		
Range maximum	3.5 m; observe system manual RF600: overrange is possible, range is reader dependent: observe http://support.automation.siemens.com/WW/view/en/67384964	3.5 m; observe system manual RF600: overrange is possible, range is reader dependent: observe
Protocol with radio transmission	EPCglobal Class 1 Gen 2 / ISO 18000-6C	EPCglobal Class 1 Gen 2 / ISO 18000-6C
Transfer rate with radio transmission maximum	320 kbit/s	320 kbit/s
Product feature multitag-capable	Yes	Yes
Polarization	Linear	Linear
Product component Backup battery	No	No
Memory		
Type of memory	EEPROM	EEPROM
Storage capacity of the user memory	64 byte	64 byte
Type of memory organization	EPC memory 96/480 bits, user memory 64/16 bytes (512/128 bits), TID memory 12 bytes	EPC memory 96/480 bits, user memory 64/16 bytes (512/128 bits), TID memory 12 bytes
Number of read cycles at ambient temperature < 40 °C maximum	100 000 000 000 000	100 000 000 000 000
Number of write cycles at ambient temperature < 40 °C maximum	500	500
Data retention time at ambient temperature < 40 °C not less than	50 y	50 y
Property of memory	lock, unlock, kill, write protection, password protection	lock, unlock, kill, write protection, password protection
Type of transponder chip used	Alien Higgs 3	Alien Higgs 3
Mechanical data		
Material	Top side: PET	Top side: PET
Color	white	white
Mounting distance relating to metal surfaces recommended minimum	0 mm	0 mm
Permitted ambient conditions		
Ambient temperature		
• during read/write access	-20 ... +85 °C	-20 ... +85 °C
• outside the read/write area	-25 ... +85 °C	-25 ... +85 °C
• during storage	13 ... 23 °C	13 ... 23 °C
Protection class IP	IP67	IP67
Resistance to mechanical stress	Torsion and bending stress conditionally permissible	Torsion and bending stress conditionally permissible

RFID systems for the UHF range

SIMATIC RF600 transponders

RF640L

	6GT2810-2AC00	6GT2810-2AC10
Article number	6GT2810-2AC00	6GT2810-2AC10
Product type designation	RF640L transponder	RF640L transponder
Suitability for operation	RF600	RF600
Design, dimensions and weight		
Width	50 mm	50 mm
Height	1.6 mm	1.6 mm
Depth	22.5 mm	22.5 mm
Net weight	4 g	4 g
Mounting type	one-side adhesible	one-side adhesible
Product properties, functions, components general		
Product feature		
• silicon-free	Yes	Yes
• printable	Yes	Yes
Printing process	Thermal transfer process	Thermal transfer process

3

Selection and ordering data

	Article No.
SIMATIC RF640L on-metal-label	
UHF Class 1 Gen2 technology (EPC 96 ... 480 bits; 16 ... 64 bytes of user memory)	
Ordering quantity 500 units (supplied on rolls) or a multiple thereof.	
• Frequency 865 ... 868 MHz (Europe)	6GT2810-2AC00
• Frequency 902 ... 928 MHz (USA, Canada)	6GT2810-2AC10

Overview

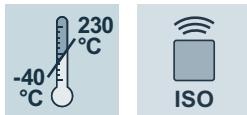
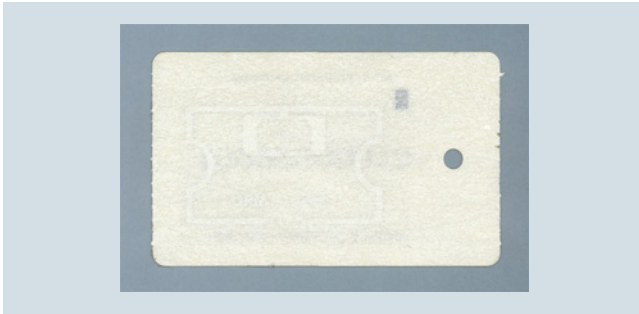

SIMATIC RF680L is a heat-resistant SmartLabel that is suitable for the identification of objects in production and logistics with high temperature requirements (e.g. for the identification of products in the paint shop/drying area).

The storage capacity is 96/240 bits for the Electronic Product Code (EPC) and 512 bits for user memory. Thanks to its broadband design, the SIMATIC RF680L SmartLabel can be used in numerous countries.

Technical specifications

Article number	6GT2810-2AG80
Product type designation	RF680L transponder
Suitability for operation	RF600
Wireless frequencies	
Operating frequency	860 ... 960 MHz
Electrical data	
Range maximum	4 m; observe system manual RF600: overrange is possible, range is reader dependent: observe http://support.automation.siemens.com/WW/view/en/67384964
Protocol with radio transmission	EPCglobal Class 1 Gen 2 / ISO 18000-6C
Transfer rate with radio transmission maximum	320 kbit/s
Product feature multitag-capable	Yes
Polarization	Linear
Product component Backup battery	No
Memory	
Type of memory	EEPROM
Storage capacity of the user memory	64 byte
Type of memory organization	EPC memory 96/240 bits, user memory 64 bytes (512 bits), TID memory 8 bytes
Number of read cycles at ambient temperature < 40 °C maximum	100 000 000 000 000
Number of write cycles at ambient temperature < 40 °C maximum	100 000
Data retention time at ambient temperature < 40 °C not less than	10 y
Property of memory	lock, unlock, kill, write protection, password protection
Type of transponder chip used	NXP G2XM

Article number	6GT2810-2AG80
Product type designation	RF680L transponder
Suitability for operation	RF600
Mechanical data	
Material	Paper
Color	beige
Mounting distance relating to metal surfaces recommended minimum	3 mm
Permitted ambient conditions	
Ambient temperature	
• during read/write access	-25 ... +85 °C
• outside the read/write area	-40 ... +230 °C
• during storage	-40 ... +85 °C
Ambient condition for operation	Operating temperature permanent up to 85 °C, for 6 hours up to 200 °C, for 1 hour up to 220 °C, short-term up to 230 °C
Protection class IP	IP60, the label must be protected against humidity
Resistance to mechanical stress	Torsion and bending stress conditionally permissible
Design, dimensions and weight	
Width	54 mm
Height	0.3 mm
Depth	89 mm
Net weight	3 g
Mounting type	gluing, cable tie, screwing
Product properties, functions, components general	
Product feature	
• silicon-free	Yes
• printable	Yes
Printing process	Thermal transfer process

Selection and ordering data

	Article No.
SIMATIC RF680L SmartLabel	6GT2810-2AG80
Frequency 865 to 960 MHz (ETSI, FCC)	
Ordering quantity 1 000 units (supplied on rolls) or a multiple thereof.	

RFID systems for the UHF range

SIMATIC RF600 transponders

RF690L

Overview

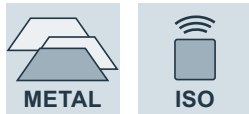

The SIMATIC RF690L heat-resistant on-metal label is designed for direct mounting on metal surfaces and under these conditions achieves a read range of up to 5 m.

This transponder is available in two frequency versions for 865 to 868 MHz (ETSI) and 902 to 928 MHz (FCC, CMIIT).

Technical specifications

Article number	6GT2810-2AG00	6GT2810-2AG10
Product type designation	RF690L transponder	RF690L transponder
Suitability for operation	RF600	RF600
Wireless frequencies		
Operating frequency	865 ... 868 MHz	902 ... 928 MHz
Electrical data		
Range maximum	5 m; observe system manual RF600: overrange is possible, range is reader dependent: observe http://support.automation.siemens.com/WW/view/en/67384964	5 m; observe system manual RF600: overrange is possible, range is reader dependent: observe
Protocol with radio transmission	EPCglobal Class 1 Gen 2 / ISO 18000-6C	EPCglobal Class 1 Gen 2 / ISO 18000-6C
Transfer rate with radio transmission maximum	320 kbit/s	320 kbit/s
Product feature multitag-capable	Yes	Yes
Polarization	Linear	Linear
Product component Backup battery	No	No
Memory		
Type of memory	EEPROM	EEPROM
Storage capacity of the user memory	64 byte	64 byte
Type of memory organization	EPC memory 96/480 bits, user memory 64/16 bytes (512/128 bits), TID memory 12 bytes	EPC memory 96/480 bits, user memory 64/16 bytes (512/128 bits), TID memory 12 bytes
Number of read cycles at ambient temperature < 40 °C maximum	100 000 000 000 000	100 000 000 000 000
Number of write cycles at ambient temperature < 40 °C maximum	500	500
Data retention time at ambient temperature < 40 °C not less than	50 y	50 y
Property of memory	lock, unlock, kill, write protection, password protection	lock, unlock, kill, write protection, password protection
Type of transponder chip used	Alien Higgs 3	Alien Higgs 3
Mechanical data		
Material	Top side: PET	Top side: PET
Color	beige / silver	beige / silver
Mounting distance relating to metal surfaces recommended minimum	0 mm	0 mm
Permitted ambient conditions		
Ambient temperature		
• during read/write access	-25 ... +85 °C	-25 ... +85 °C
• outside the read/write area	Higher temperatures on request	Higher temperatures on request
• during storage	13 ... 23 °C	13 ... 23 °C
Ambient condition for operation	Operating temperature permanent up to 85 °C, higher temperatures on request	Operating temperature permanent up to 85 °C, higher temperatures on request
Protection class IP	IP67	IP67
Resistance to mechanical stress	Torsion and bending stress conditionally permissible	Torsion and bending stress conditionally permissible

RFID systems for the UHF range

SIMATIC RF600 transponders

RF690L

Article number	6GT2810-2AG00	6GT2810-2AG10
Product type designation	RF690L transponder	RF690L transponder
Suitability for operation	RF600	RF600
Design, dimensions and weight		
Width	88 mm	75 mm
Height	1.6 mm	1.6 mm
Depth	25 mm	25 mm
Net weight	5 g	5 g
Mounting type	one-side adhesible	one-side adhesible
Product properties, functions, components general		
Product feature		
• silicon-free	Yes	Yes
• printable	Yes	Yes
Printing process	Thermal transfer process	Thermal transfer process

Selection and ordering data

	Article No.
SIMATIC RF690L heat-resistant on-metal-label UHF Class 1 Gen2 technology (EPC 96 ... 480 bits; 16 ... 64 bytes of user memory) Ordering quantity 400 units (supplied on rolls) or a multiple thereof.	
<ul style="list-style-type: none"> • Frequency 865 ... 868 MHz (Europe) 	6GT2810-2AG00
<ul style="list-style-type: none"> • Frequency 902 ... 928 MHz (USA, Canada) 	6GT2810-2AG10

3

RFID systems for the UHF range

SIMATIC RF600 transponders

RF610T

Overview

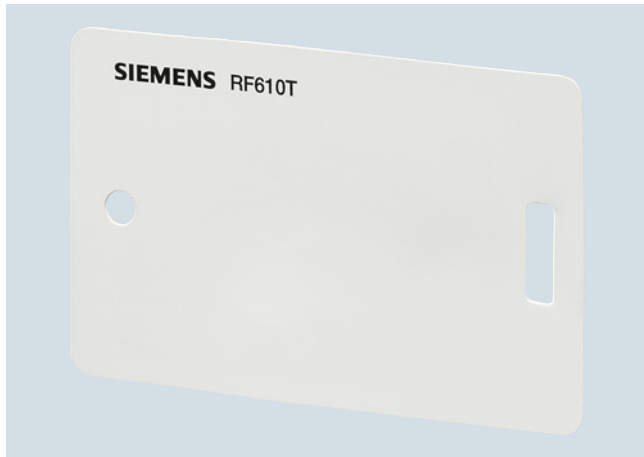

The SIMATIC RF610T transponder is a flexible card in ISO format that is suitable for a wide variety of applications, e.g. for identification of containers, pallets, vessels, or trolleys. SIMATIC RF610T can be attached to the most diverse materials, including plastic, wood, glass and, with a spacer, metal.

The plastic enclosure is designed for food safety and is therefore also suitable for use with food and beverages. Thanks to its broadband design, the transponder can be used in numerous countries.

3



6GT2810-2BB80





6GT28102BB80-0AX1

Technical specifications

	6GT2810-2BB80	6GT2810-2BB80-0AX1
Article number	6GT2810-2BB80	6GT2810-2BB80-0AX1
Product type designation	RF610T transponder	RF610T transponder
Suitability for operation	RF600	RF600
Wireless frequencies		
Operating frequency	860 ... 960 MHz	860 ... 960 MHz
Electrical data		
Range maximum	5 m; observe system manual RF600: overrange is possible, range is reader dependent: observe http://support.automation.siemens.com/WWW/view/en/67384964	5 m; observe system manual RF600: overrange is possible, range is reader dependent: observe
Protocol with radio transmission	EPCglobal Class 1 Gen 2 / ISO 18000-6C	EPCglobal Class 1 Gen 2 / ISO 18000-6C
Transfer rate with radio transmission maximum	320 kbit/s	320 kbit/s
Product feature multitag-capable	Yes	Yes
Polarization	Linear	Linear
Product component Backup battery	No	No
Memory		
Type of memory	EEPROM	EEPROM
Storage capacity of the user memory	64 byte	64 byte
Type of memory organization	EPC memory 96/240 bits, user memory 64 bytes (512 bits), TID memory 8 bytes	EPC memory 96/240 bits, user memory 64 bytes (512 bits), TID memory 8 bytes
Number of read cycles at ambient temperature < 40 °C maximum	100 000 000 000 000	100 000 000 000 000
Number of write cycles at ambient temperature < 40 °C maximum	100 000	100 000
Data retention time at ambient temperature < 40 °C not less than	10 y	10 y
Property of memory	lock, unlock, write protection, password protection	lock, unlock, write protection, password protection
Type of transponder chip used	NXP G2XM	NXP G2XM

Article number	6GT2810-2BB80	6GT2810-2BB80-0AX1
Product type designation	RF610T transponder	RF610T transponder
Suitability for operation	RF600	RF600
Mechanical data		
Material	PVC, food-safe	PVC, food-safe
Color	white	white
Mounting distance relating to metal surfaces recommended minimum	3 mm	3 mm
Permitted ambient conditions		
Ambient temperature		
• during read/write access	-25 ... +85 °C	-25 ... +85 °C
• outside the read/write area	-40 ... +85 °C	-40 ... +85 °C
• during storage	-40 ... +85 °C	-40 ... +85 °C
Protection class IP	IP67	IP67
Shock resistance	According to DIN EN 60721-3-7 Class 7 M3	According to DIN EN 60721-3-7 Class 7 M3
Shock acceleration	1 000 m/s ²	1 000 m/s ²
Vibrational acceleration	500 m/s ²	500 m/s ²
Resistance to mechanical stress	Torsion and bending stress conditionally permissible	Torsion and bending stress conditionally permissible
Design, dimensions and weight		
Width	54 mm	54 mm
Height	0.4 mm	0.4 mm
Depth	86 mm	86 mm
Net weight	3 g	3 g
Mounting type	gluing, cable tie, screwing	gluing, cable tie, screwing
Product properties, functions, components general		
Product feature		
• printable	Yes	Yes
Printing process	Thermal transfer process	Thermal transfer process
Standards, specifications, approvals		
Certificate of suitability		Ex: II 3 G Ex ic IIB T6 to T4, II 3 D Ex ic IIIB T120°C, -25 °C < Ta < +85 °C
MTBF	1 712 y	1 712 y
Accessories		

Selection and ordering data

	Article No.		Article No.
SIMATIC RF610T ISO card transponder		Spacer	6GT2190-0AA00
<ul style="list-style-type: none"> Frequency 865 MHz to 960 MHz (ETSI, FCC). Ordering quantity 500 units or a multiple thereof. Same as before but with ATEX certification Ordering quantity 1 000 units or a multiple thereof. 	6GT2810-2BB80 6GT2810-2BB80-0AX0	to metal surfaces, in combination with fixing pocket 6GT2190-0AB00. Ordering quantity 50 units or a multiple thereof.	
Accessories			
Fixing pocket	6GT2190-0AB00		
For SIMATIC RF610T, for attaching to metal surfaces in combination with spacer 6GT2190-0AA00. Ordering quantity 50 units or a multiple thereof.			
			

Dimensional drawings

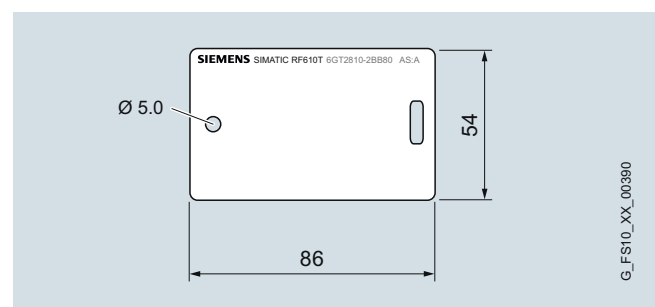

SIMATIC RF610T transponder

RFID systems for the UHF range

SIMATIC RF600 transponders

RF620T

Overview

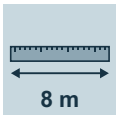

The SIMATIC RF620T container transponder is designed for industrial requirements and has a high immunity to environmental effects and detergents. It can be attached to plastic, wood or glass. The RF620T can also be mounted on metal and ESD plastic with a spacer.

The SIMATIC RF620T transponder is suitable for identification of transport containers, pallets or vessels. The plastic enclosure is food safe. Thanks to its broadband design, the transponder can be used in numerous countries.

Technical specifications

Article number	6GT2810-2HC81
Product type designation	RF620T transponder
Suitability for operation	RF600
Wireless frequencies	
Operating frequency	860 ... 960 MHz
Electrical data	
Range maximum	8 m; observe system manual RF600: overrange is possible, range is reader dependent: observe
http://support.automation.siemens.com/WWW/view/en/67384964	
Protocol with radio transmission	EPCglobal Class 1 Gen 2 / ISO 18000-6C
Transfer rate with radio transmission maximum	320 kbit/s
Product feature multitag-capable	Yes
Polarization	Linear
Product component Backup battery	No
Memory	
Type of memory	EEPROM
Storage capacity of the user memory	64 byte
Type of memory organization	EPC memory 96/128 bits, user memory 64 bytes (512 bits), TID memory 4 bytes
Number of read cycles at ambient temperature < 40 °C maximum	100 000 000 000 000
Number of write cycles at ambient temperature < 40 °C maximum	100 000
Data retention time at ambient temperature < 40 °C not less than	10 y
Property of memory	lock, unlock, write protection, password protection
Type of transponder chip used	IMPINJ MONZA 4QT

Article number	6GT2810-2HC81
Product type designation	RF620T transponder
Suitability for operation	RF600
Mechanical data	
Material	PP (polypropylene)
Color	anthracite
Tightening torque of the screw for securing the equipment maximum	1.2 Nm
Mounting distance relating to metal surfaces recommended minimum	0 mm
Permitted ambient conditions	
Ambient temperature	
• during read/write access	-25 ... +85 °C
• outside the read/write area	-40 ... +85 °C
• during storage	-40 ... +80 °C
Protection class IP	IP67
Shock resistance	According to DIN EN 60721-3-7 Class 7 M3
Shock acceleration	1 000 m/s ²
Vibrational acceleration	500 m/s ²
Resistance to mechanical stress	Torsion and bending stress not per- missible
Design, dimensions and weight	
Width	38 mm
Height	6 mm
Depth	127 mm
Net weight	18 g
Mounting type	gluing, 2 x M5 screws, spacer (see accessories)
Product properties, functions, components general	
Product feature	
• printable	Yes
Printing process	Laser inscription
Accessories	
Accessories	Spacers

Selection and ordering data

	Article No.
SIMATIC RF620T container transponder Frequency 860 MHz to 960 MHz (ETSI, FCC) Ordering quantity 20 units or a multiple thereof.	6GT2810-2HC81
Accessories	
Spacer For SIMATIC RF620T, for mounting on metal; dimensions L x W x H (mm) 155 x 38 x 12 Ordering quantity 20 units or a multiple thereof.	6GT2898-2AA00

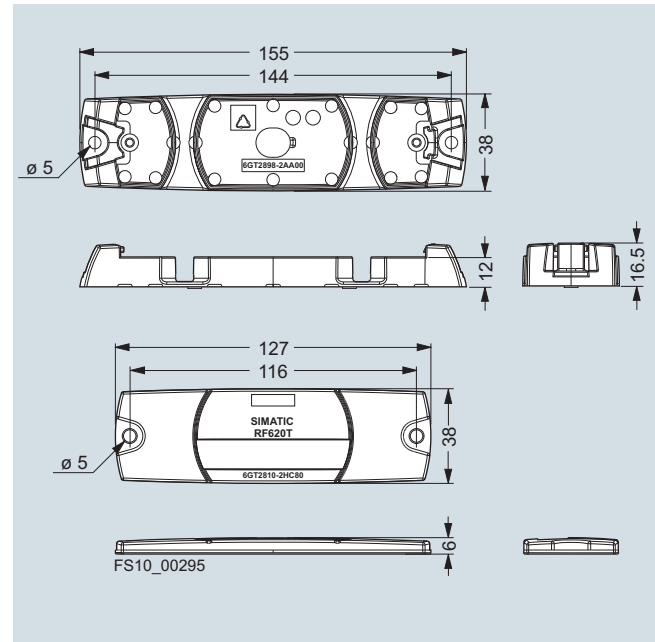
Dimensional drawings

SIMATIC RF620T container transponder

RFID systems for the UHF range

SIMATIC RF600 transponders

RF622T

Overview

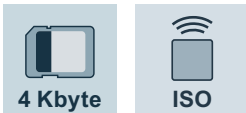

The SIMATIC RF622T transponder has a capacity of 4 KB FRAM, and enables the storage of up to 3 424 bytes of user data on tagged objects, as well as facilitating rapid access to them. It is therefore ideally suited to use in distributed configurations in the fields of production control, asset management and intra-logistics.

The SIMATIC RF622T offers a considerable reading range of up to 3 meters on non-metallic surfaces. It can also be fixed directly to metal surfaces using the optional spacer.

Technical specifications

Article number	6GT2810-4HC80
Product type designation	RF622T transponder
Suitability for operation	RF600
Wireless frequencies	
Operating frequency	860 ... 960 MHz
Electrical data	
Range maximum	3 m; observe system manual RF600: overrange is possible, range is reader dependent: observe
http://support.automation.siemens.com/WWW/view/en/67384964	
Protocol with radio transmission	EPCglobal Class 1 Gen 2 / ISO 18000-6C
Transfer rate with radio transmission maximum	320 kbit/s
Product feature multitag-capable	Yes
Polarization	Linear
Product component Backup battery	No
Memory	
Type of memory	FRAM
Storage capacity of the user memory	3 424 byte
Type of memory organization	EPC memory 496 bits, user memory 3 424 bytes, TID memory 32 bytes
Number of read cycles at ambient temperature < 40 °C maximum	10 000 000 000
Number of write cycles at ambient temperature < 40 °C maximum	10 000 000 000
Data retention time at ambient temperature < 40 °C not less than	10 y
Property of memory	lock, unlock, write protection, pass- word protection
Type of transponder chip used	Fujitsu MB97R803

Article number	6GT2810-4HC80
Product type designation	RF622T transponder
Suitability for operation	RF600
Mechanical data	
Material	PA12
Color	anthracite
Tightening torque of the screw for securing the equipment maximum	1 Nm
Mounting distance relating to metal surfaces recommended minimum	5 mm
Permitted ambient conditions	
Ambient temperature	
• during read/write access	-20 ... +85 °C
• outside the read/write area	-40 ... +85 °C
• during storage	-40 ... +80 °C
Protection class IP	IP67
Shock resistance	According to DIN EN 60721-3-7 Class 7 M3
Shock acceleration	1 000 m/s ²
Vibrational acceleration	500 m/s ²
Resistance to mechanical stress	Torsion and bending stress not permissible
Design, dimensions and weight	
Width	120 mm
Height	6.5 mm
Depth	30 mm
Net weight	4 g
Mounting type	2 screws M4, spacer (see accessories)
Product properties, functions, components general	
Product feature	
• silicon-free	Yes
• printable	Yes
Printing process	Laser inscription
Accessories	
Accessories	Spacers

Selection and ordering data

	Article No.
SIMATIC RF622T SmartLabel Frequency: 860 to 960 MHz, EPC: 496 bits, user memory: 3 424 bytes Plastic, dimensions (mm): 120 x 30 x 6.5; ordering quantity 10 units or a multiple thereof.	6GT2810-4HC80
Accessories	
Spacer Spacer, necessary for fixing to metal surfaces Dimensions (mm): 130 x 31.5 x 12; ordering quantity 10 units or a multiple thereof.	6GT2898-3AA00



Dimensional drawings

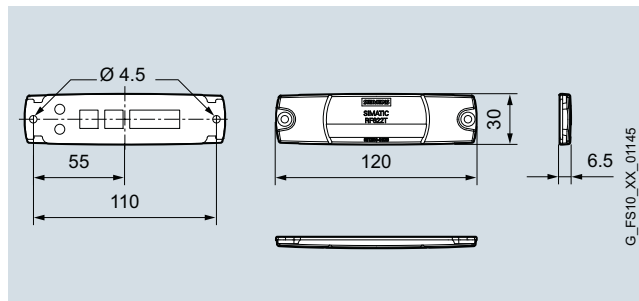

RF622T large-memory transponder

RFID systems for the UHF range

SIMATIC RF600 transponders

RF625T

Overview



The SIMATIC RF625T disk transponder can be recessed in metal, as well as flush-mounted on metal and on non-metallic surfaces.

Thanks to its rugged design and high IP68 degree of protection, it is ideal for use in industrial environments, even for demanding production processes.

The SIMATIC RF625T can not only be used for applications in the field of installation, production and logistics, but also for the permanent equipping of tools, machines and plants for RFID-based asset management.

This transponder is available in two frequency versions for 865 to 868 MHz (ETSI) and 902 to 928 MHz (FCC, CMIIT).



Technical specifications

	6GT2810-2EE00	6GT2810-2EE01
Article number	RF625T transponder	RF600
Product type designation	RF625T transponder	RF600
Suitability for operation	RF600	RF600
Wireless frequencies		
Operating frequency	865 ... 868 MHz	902 ... 928 MHz
Electrical data		
Range maximum	1.5 m; observe system manual RF600: overrange is possible, range is reader dependent: observe http://support.automation.siemens.com/WW/view/en/67384964	1.5 m; observe system manual RF600: overrange is possible, range is reader dependent: observe
Protocol with radio transmission	EPCglobal Class 1 Gen 2 / ISO 18000-6C	EPCglobal Class 1 Gen 2 / ISO 18000-6C
Transfer rate with radio transmission maximum	320 kbit/s	320 kbit/s
Product feature multitag-capable	Yes	Yes
Polarization	Linear	Linear
Product component Backup battery	No	No
Memory		
Type of memory	EEPROM	EEPROM
Storage capacity of the user memory	64 byte	64 byte
Type of memory organization	EPC memory 96/128 bits, user memory 64 bytes (512 bits), TID memory 4 bytes	EPC memory 96/128 bits, user memory 64 bytes (512 bits), TID memory 4 bytes
Number of read cycles at ambient temperature < 40 °C maximum	100 000 000 000 000	100 000 000 000 000
Number of write cycles at ambient temperature < 40 °C maximum	100 000	100 000
Data retention time at ambient temperature < 40 °C not less than	10 y	10 y
Property of memory	lock, unlock, write protection, password protection	lock, unlock, write protection, password protection
Type of transponder chip used	IMPINJ MONZA 4QT	IMPINJ MONZA 4QT
Mechanical data		
Material	PA6.6	PA6.6
Color	black	black
Tightening torque of the screw for securing the equipment maximum	1 Nm	1 Nm
Mounting distance relating to metal surfaces recommended minimum	0 mm	0 mm

Article number	6GT2810-2EE00	6GT2810-2EE01
Product type designation	RF625T transponder	RF625T transponder
Suitability for operation	RF600	RF600
Permitted ambient conditions		
Ambient temperature		
• during read/write access	-25 ... +85 °C	-25 ... +85 °C
• outside the read/write area	-40 ... +125 °C	-40 ... +125 °C
• during storage	-40 ... +125 °C	-40 ... +125 °C
Protection class IP	IP68 / IPx9K	IP68 / IPx9K
Shock resistance	According to DIN EN 60721-3-7 Class 7 M3	According to DIN EN 60721-3-7 Class 7 M3
Shock acceleration	1 000 m/s ²	1 000 m/s ²
Vibrational acceleration	500 m/s ²	500 m/s ²
Design, dimensions and weight		
Height	8 mm	8 mm
Diameter	30 mm	30 mm
Mounting type	gluing, M3 screw	gluing, M3 screw
Product properties, functions, components general		
Product feature		
• printable	No	No
Standards, specifications, approvals		
MTBF	1 141 y	1 141 y

Selection and ordering data

	Article No.
SIMATIC RF625T disk transponder	
Ordering quantity 20 units or a multiple thereof.	
• Frequency 865 MHz to 868 MHz (ETSI)	6GT2810-2EE00
• Frequency 902 MHz to 928 MHz (FCC)	6GT2810-2EE01

Dimensional drawings

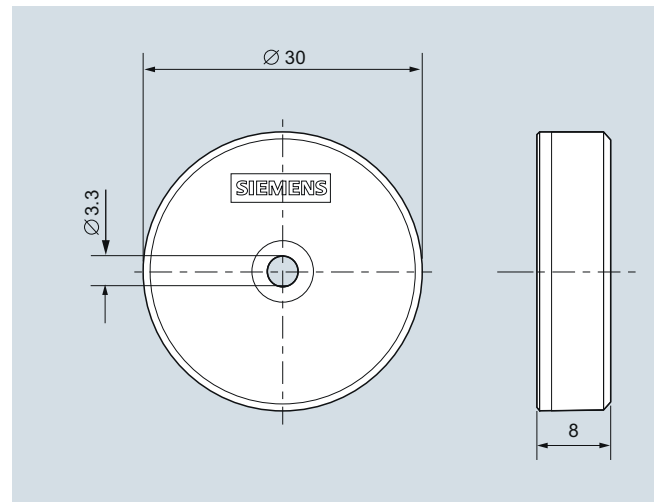

SIMATIC RF625T disk transponder

RFID systems for the UHF range

SIMATIC RF600 transponders

RF630T

Overview



The SIMATIC RF630T screw transponder is particularly suitable for controlling and monitoring production processes. It can be automatically screwed on to products such as motors or gearbox casings by means of robots and using the M6 grub screw.

The SIMATIC RF630T is suitable for industrial requirements. Its rugged and highly resistant to detergents.

It can be attached to materials such as plastic or wood as well as directly onto metal.

This transponder is available in two frequency versions for 865 to 868 MHz (ETSI) and 902 to 928 MHz (FCC, CMIIT).



Technical specifications

	6GT2810-2EC00	6GT2810-2EC10
Article number	RF630T transponder	RF630T transponder
Product type designation	RF600	RF600
Suitability for operation		
Wireless frequencies		
Operating frequency	865 ... 868 MHz	902 ... 928 MHz
Electrical data		
Range maximum	2 m; observe system manual RF600: overrange is possible, range is reader dependent: observe http://support.automation.siemens.com/WW/view/en/67384964	2 m; observe system manual RF600: overrange is possible, range is reader dependent: observe
Protocol with radio transmission	EPCglobal Class 1 Gen 2 / ISO 18000-6C	EPCglobal Class 1 Gen 2 / ISO 18000-6C
Transfer rate with radio transmission maximum	320 kbit/s	320 kbit/s
Product feature multitag-capable	Yes	Yes
Polarization	Linear	Linear
Product component Backup battery	No	No
Memory		
Type of memory	EEPROM	EEPROM
Storage capacity of the user memory	64 byte	64 byte
Type of memory organization	EPC memory 96/240 bits, user memory 64 bytes (512 bits), TID memory 8 bytes	EPC memory 96/240 bits, user memory 64 bytes (512 bits), TID memory 8 bytes
Number of read cycles at ambient temperature < 40 °C maximum	100 000 000 000 000	100 000 000 000 000
Number of write cycles at ambient temperature < 40 °C maximum	100 000	100 000
Data retention time at ambient temperature < 40 °C not less than	10 y	10 y
Property of memory	lock, unlock, write protection, password protection	lock, unlock, write protection, password protection
Type of transponder chip used	NXP G2XM	NXP G2XM
Mechanical data		
Material	PA6.6 GF / stainless steel	PA6.6 GF / stainless steel
Color	black silver	black silver
Tightening torque of the screw for securing the equipment maximum	6 Nm	6 Nm
Mounting distance relating to metal surfaces recommended minimum	0 mm	0 mm

Article number	6GT2810-2EC00	6GT2810-2EC10
Product type designation	RF630T transponder	RF630T transponder
Suitability for operation	RF600	RF600
Permitted ambient conditions		
Ambient temperature		
• during read/write access	-25 ... +85 °C	-25 ... +85 °C
• outside the read/write area	-40 ... +125 °C	-40 ... +125 °C
• during storage	-40 ... +125 °C	-40 ... +125 °C
Protection class IP	IP68 / IPx9K	IP68 / IPx9K
Shock resistance	According to DIN EN 60721-3-7 Class 7 M3	According to DIN EN 60721-3-7 Class 7 M3
Shock acceleration	1 000 m/s ²	1 000 m/s ²
Vibrational acceleration	200 m/s ²	200 m/s ²
Design, dimensions and weight		
Height	20 mm	20 mm
Diameter	21 mm	21 mm
Net weight	22 g	22 g
Mounting type	screwing (M6)	screwing (M6)
Product properties, functions, components general		
Product feature		
• printable	No	No
Standards, specifications, approvals		
MTBF	1 712 y	1 712 y

Selection and ordering data

	Article No.
SIMATIC RF630T screw transponder	
Ordering quantity 10 units or a multiple thereof.	
• Frequency 865 to 868 MHz (ETSI)	6GT2810-2EC00
• Frequency 902 to 928 MHz (FCC)	6GT2810-2EC10

Dimensional drawings

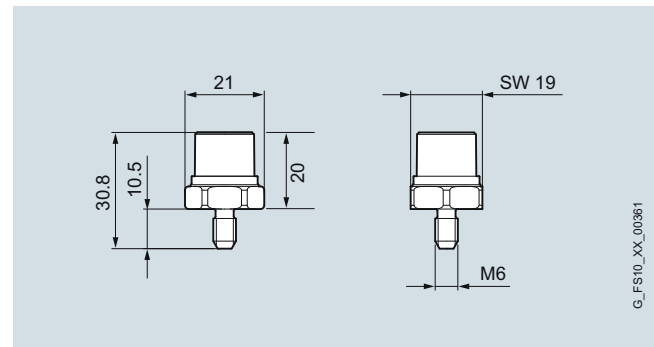

SIMATIC RF630T screw transponder

RFID systems for the UHF range

SIMATIC RF600 transponders

RF640T

Overview



The SIMATIC RF640T tool transponder can be used directly on metal, and is therefore particularly suitable for tracking tools, containers and metallic equipment (asset management).

Its rugged and yet compact design, its high degree of protection (IP68/IPx9K) and resistance to mineral oils, lubricants and cleaning agents make it the first choice in industrial environments. The European version has ATEX approval.

This transponder is available in two frequency versions for 865 to 868 MHz (ETSI) and 902 to 928 MHz (FCC, CMIIT).



Technical specifications

	6GT2810-2DC00	6GT2810-2DC10
Article number	6GT2810-2DC00	6GT2810-2DC10
Product type designation	RF640T transponder	RF640T transponder
Suitability for operation	RF600	RF600
Wireless frequencies		
Operating frequency	865 ... 868 MHz	902 ... 928 MHz
Electrical data		
Range maximum	4 m; observe system manual RF600: overrange is possible, range is reader dependent: observe http://support.automation.siemens.com/WW/view/en/67384964	4 m; observe system manual RF600: overrange is possible, range is reader dependent: observe
Protocol with radio transmission	EPCglobal Class 1 Gen 2 / ISO 18000-6C	EPCglobal Class 1 Gen 2 / ISO 18000-6C
Transfer rate with radio transmission maximum	320 kbit/s	320 kbit/s
Product feature multitag-capable	Yes	Yes
Polarization	Linear	Linear
Product component Backup battery	No	No
Memory		
Type of memory	EEPROM	EEPROM
Storage capacity of the user memory	64 byte	64 byte
Type of memory organization	EPC memory 96/240 bits, user memory 64 bytes (512 bits), TID memory 8 bytes	EPC memory 96/240 bits, user memory 64 bytes (512 bits), TID memory 8 bytes
Number of read cycles at ambient temperature < 40 °C maximum	100 000 000 000 000	100 000 000 000 000
Number of write cycles at ambient temperature < 40 °C maximum	100 000	100 000
Data retention time at ambient temperature < 40 °C not less than	10 y	10 y
Property of memory	lock, unlock, write protection, password protection	lock, unlock, write protection, password protection
Type of transponder chip used	NXP G2XM	NXP G2XM

Article number	6GT2810-2DC00	6GT2810-2DC10
Product type designation	RF640T transponder	RF640T transponder
Suitability for operation	RF600	RF600
Mechanical data		
Material	PA12	PA12
Color	anthracite	anthracite
Tightening torque of the screw for securing the equipment maximum	1.2 Nm	1.2 Nm
Mounting distance relating to metal surfaces recommended minimum	0 mm	0 mm
Permitted ambient conditions		
Ambient temperature		
• during read/write access	-25 ... +85 °C	-25 ... +85 °C
• outside the read/write area	-40 ... +125 °C	-40 ... +125 °C
• during storage	-40 ... +125 °C	-40 ... +125 °C
Protection class IP	IP68 / IPx9K	IP68 / IPx9K
Shock resistance	According to DIN EN 60721-3-7 Class 7 M3	According to DIN EN 60721-3-7 Class 7 M3
Shock acceleration	1 000 m/s ²	1 000 m/s ²
Vibrational acceleration	200 m/s ²	200 m/s ²
Design, dimensions and weight		
Height	8 mm	8 mm
Diameter	50 mm	50 mm
Net weight	13 g	13 g
Mounting type	2 x M4 screws	2 x M4 screws
Product properties, functions, components general		
Product feature		
• silicon-free	Yes	Yes
• printable	No	No
Standards, specifications, approvals		
Certificate of suitability	Ex: II 2 G Ex ib IIC T6 to T3, II 2 D Ex ibD 21 T140°C, -25 °C < Ta° < +85 °C	
MTBF	1 757 y	1 757 y

Selection and ordering data

	Article No.
SIMATIC RF640T tool transponder	
Ordering quantity 10 units or a multiple thereof.	
• Frequency 865 MHz to 868 MHz (ETSI)	6GT2810-2DC00
• Frequency 902 MHz to 928 MHz (FCC)	6GT2810-2DC10

Dimensional drawings

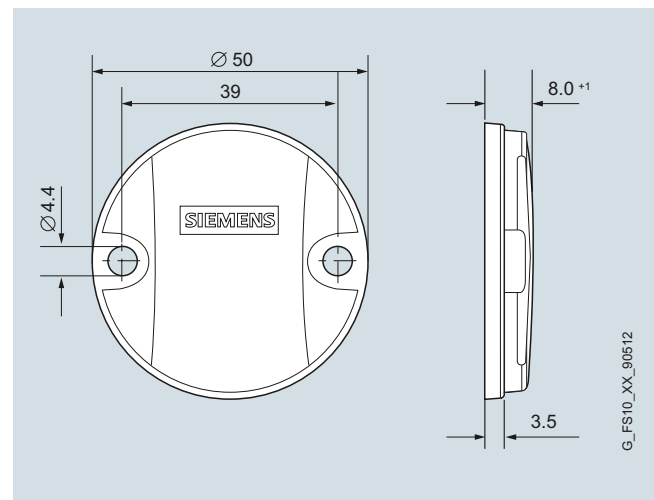

SIMATIC RF640T tool transponder

RFID systems for the UHF range

SIMATIC RF600 transponders

RF680T

Overview

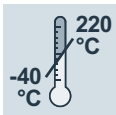

The heat-resistant SIMATIC RF680T transponder has a wide range and, thanks to its high IP68/IPx9K degree of protection and its resistance to chemicals, it can even be used in harsh industrial applications, for example, in automotive production (including identification of skids in paint shops) or in the chemical industry. The transponder is silicon-free and withstands temperatures up to 220 °C. The storage capacity is 96/240 bit Electronic Product Code (EPC) plus 512-bit user memory. Thanks to its broadband design, the transponder can be used in numerous countries. The European version has ATEX approval.

Technical specifications

Article number	6GT2810-2HG80
Product type designation	RF680T transponder
Suitability for operation	RF600
Wireless frequencies	
Operating frequency	865 ... 928 MHz
Electrical data	
Range maximum	4 m; observe system manual RF600: overrange is possible, range is reader dependent: observe
http://support.automation.siemens.com/WWW/view/en/67384964	
Protocol with radio transmission	EPCglobal Class 1 Gen 2 / ISO 18000-6C
Transfer rate with radio transmission maximum	320 kbit/s
Product feature multitag-capable	Yes
Polarization	Linear
Product component Backup battery	No
Memory	
Type of memory	EEPROM
Storage capacity of the user memory	64 byte
Type of memory organization	EPC memory 96/240 bits, user memory 64 bytes (512 bits), TID memory 8 bytes
Number of read cycles at ambient temperature < 40 °C maximum	100 000 000 000 000
Number of write cycles at ambient temperature < 40 °C maximum	100 000
Data retention time at ambient temperature < 40 °C not less than	10 y
Property of memory	lock, unlock, write protection, password protection
Type of transponder chip used	NXP G2XM

Article number	6GT2810-2HG80
Product type designation	RF680T transponder
Suitability for operation	RF600
Mechanical data	
Material	PPS
Color	black
Tightening torque of the screw for securing the equipment maximum	1 Nm
Mounting distance relating to metal surfaces recommended minimum	0 mm
Permitted ambient conditions	
Ambient temperature	
• during read/write access	-25 ... +100 °C
• outside the read/write area	-40 ... +220 °C
• during storage	-40 ... +100 °C
Ambient condition for operation	Operating temperature permanent up to 140 °C, for 5 000 hours or 3 000 cycles up to 200 °C, for 2 000 hours or 1 500 cycles up to 220 °C
Protection class IP	IP68 / IPx9K
Shock resistance	According to DIN EN 60721-3-7 Class 7 M3
Shock acceleration	1 000 m/s ²
Vibrational acceleration	200 m/s ²
Resistance to mechanical stress	Torsion and bending stress not permissible
Design, dimensions and weight	
Width	32 mm
Height	15 mm
Depth	130 mm
Net weight	50 g
Mounting type	2 x M6 screws
Product properties, functions, components general	
Product feature	
• silicon-free	Yes
• printable	No
Standards, specifications, approvals	
Certificate of suitability	II 2G Ex ib IIB T6 to T2 Gb, II 2D Ex ib IIB T135 °C Db
MTBF	1 940 y

Selection and ordering data

	Article No.
SIMATIC RF680T high-temperature transponder Frequency 865 to 928 MHz (ETSI, FCC, CMIIT). Ordering quantity 10 units or a multiple thereof.	6GT2810-2HG80

Dimensional drawings

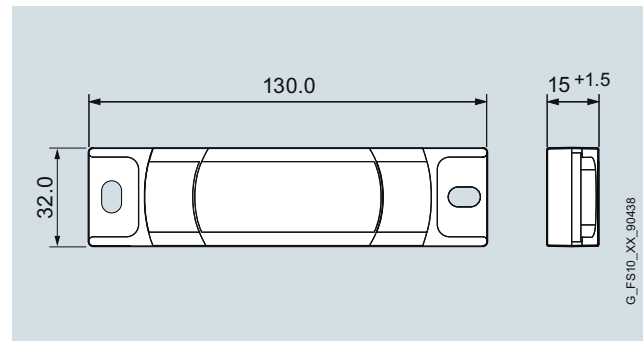





SIMATIC RF680T high-temperature transponder

RFID systems for the UHF range

SIMATIC RF600 readers

Introduction

Overview

Reader	Features	Page	Reader	Features	Page
RF650R 	<p>The SIMATIC RF650R reader is a powerful UHF-RFID reader for use with as many as four external antennas.</p> <p>The reader is connected to the IT level via Ethernet and TCP/IP (XML protocol).</p>	3/30	RF650M 	<p>The SIMATIC RF650M mobile handheld terminal is a powerful and compact RFID reader for applications in the field of production logistics, warehouse management, inventories and service.</p> <p>Transponder data can be displayed and edited using a preinstalled application. Furthermore, specific Windows applications can be developed for the device.</p> <p>The handheld forwards the data stored on the transponder to the downstream systems via either WLAN or the interfaces of the docking station (USB, Ethernet).</p>	3/41
RF680R 	<p>The SIMATIC RF680R reader is a powerful UHF-RFID reader for use with as many as four external antennas.</p> <p>There are two methods of integrating the reader into an automation system: Either directly via the integrated PROFINET interface or via the ASM 456 communication module on PROFIBUS.</p> <p>The readers are connected to the IT level via Ethernet with TCP/IP and XML.</p>	3/33			
RF685R 	<p>The SIMATIC RF685R reader is a powerful UHF RFID reader with an integral antenna and a connection for an external antenna.</p> <p>There are two methods of integrating the reader into an automation system: Either directly via the integrated PROFINET interface or via the ASM 456 communication module on PROFIBUS.</p> <p>The readers are connected to the IT level via Ethernet with TCP/IP and XML.</p>	3/37			

Overview

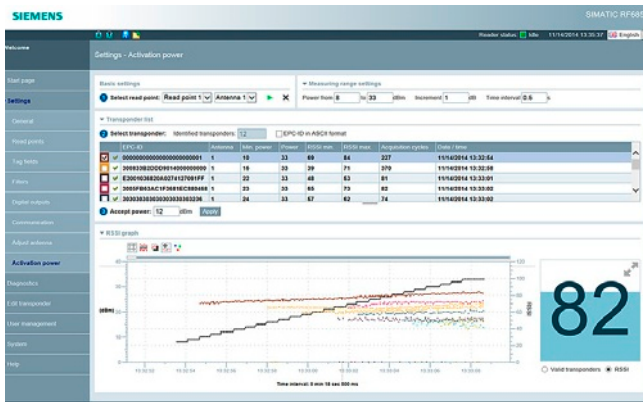

Software installations for commissioning or diagnostics are a thing of the past with the SIMATIC RF650R, RF680R and RF685R readers. The user interface can be easily called up with an Internet browser. In this way, maintenance engineers, for example, can connect remotely to a reader and carry out the relevant tasks from the office.

The orientation of the antennas is accomplished within a few minutes with the aid of the corresponding menu. The Web-based interface gives the user immediate feedback about how changing the antenna position or orientation affects the acquisition. Especially practical: The same information is also shown via a brightly lit LED row on the housing of the reader – so that the setup can also be performed in obstructed installations.

In the Diagnostics menu, all information necessary to assess the quality of the reading results during operation is displayed, e.g. the signal strength (RSSI), the acquisition frequency and the transmitting power effectively used.

Moreover, even the transponders filtered out on the basis of the "UHF for Industry" algorithms used are shown. The effect of these filter functions can thus be easily analyzed and their parameters quickly optimized.

A built-in diagnostics log records all events including read and write errors or changes made to the parameters of the reader. In this way, a "glimpse into the past" can be made to retrospectively analyze a sporadically occurring error, for example.

RFID systems for the UHF range

SIMATIC RF600 readers

RF650R

Overview



The high-performance SIMATIC RF650R reader has four antenna connections that can be configured as required for individual read stations, or as gates. The high radiated power of up to 2 W ERP / 4 W EIRP (dependent on antenna and cable) permits long ranges of up to 8 m in portal applications.

The integrated processing logic of the reader enables numerous functions of the higher-level software layers to be executed in the device itself. If necessary, the digital outputs for signaling functions are automatically controlled. The advantage of the SIMATIC RF650R is that its intelligence considerably reduces the cost for additional software modules (RFID middleware).

Configuration, commissioning and diagnosis is performed via an easy-to-use Web interface that can be operated with a standard Internet browser.

The reader supports commissioning, such as the orientation of the antenna(s), or the determining of the necessary radiant power by means of corresponding tools. A variety of diagnostic displays, such as the live radio signal diagram or the diagnostic logbook considerably simplifies and speeds up troubleshooting.

Data communication in the SIMATIC RF650R is executed by means of an XML protocol via TCP/IP. The digital inputs and outputs (DI/DO) are used for simple process interfacing (sensors, actuators).

All antennas of the RF600 series are supported.

Application

The stationary SIMATIC RF650R reader with its integral antenna is ideal for typical gate applications in logistics, distribution, supply chain management and asset management.

The SIMATIC RF650R supports the established EPCglobal Class 1, Gen 2 standard, among others, and is offered in three versions: compliant with ETSI for Europe, FCC for USA/Canada, and CMIIT for China.

Technical specifications

Article number	6GT2811-6AB20-0AA0	6GT2811-6AB20-1AA0	6GT2811-6AB20-2AA0
Product type designation	RF650R ETSI reader	RF650R FCC reader	RF650R CMIIT reader
Suitability for operation	RF600 transponders, for connecting via Ethernet	RF600 transponders, for connecting via Ethernet	RF600 transponders, for connecting via Ethernet
Wireless frequencies			
Operating frequency	865 ... 868 MHz	902 ... 928 MHz	920 ... 925 MHz
Transmit power	3 ... 1 000 mW	3 ... 1 000 mW	3 ... 1 000 mW
Effective radiant power			
• for each external antenna maximum	2 000 mW		2 000 mW
Equivalent isotropically radiated power			
• for each external antenna maximum		4 000 mW	
Electrical data			
Range maximum	8 m; Observe system manual RF600: Overreaches are possible, range is dependent on transponder type: observe http://support.automation.siemens.com/WW/view/en/67384964	8 m; Observe system manual RF600: Overreaches are possible, range is dependent on transponder type: observe	8 m; Observe system manual RF600: Overreaches are possible, range is dependent on transponder type: observe
Protocol with radio transmission	EPCglobal Class 1 Gen 2 / ISO 18000-6B/-6C	EPCglobal Class 1 Gen 2 / ISO 18000-6B/-6C	EPCglobal Class 1 Gen 2 / ISO 18000-6B/-6C
Transfer rate with radio transmission maximum	300 kbit/s	300 kbit/s	300 kbit/s
Product feature multitag-capable	Yes	Yes	Yes
Transmission time for user data			
• for write access per byte typical	2 ms	2 ms	2 ms
• for read access per byte typical	0.15 ms	0.15 ms	0.15 ms

RFID systems for the UHF range

SIMATIC RF600 readers

RF650R



Article number	6GT2811-6AB20-0AA0	6GT2811-6AB20-1AA0	6GT2811-6AB20-2AA0
Product type designation	RF650R ETSI reader	RF650R FCC reader	RF650R CMIIT reader
Interfaces			
Number of external antennas	4	4	4
Standard for interfaces for communication	Ethernet	Ethernet	Ethernet
Type of electrical connection			
• for external antenna(s)	RP-TNC	RP-TNC	RP-TNC
• for supply voltage	M12, 8-pin, connector	M12, 8-pin, connector	M12, 8-pin, connector
• for communications interface	RJ45	RJ45	RJ45
• at the digital inputs/outputs	M12, 12-pin, female connector	M12, 12-pin, female connector	M12, 12-pin, female connector
Number of digital inputs	4	4	4
Number of digital outputs	4	4	4
Mechanical data			
Material	Aluminum, Pocan	Aluminum, Pocan	Aluminum, Pocan
Color	silver, TI-Grey	silver, TI-Grey	silver, TI-Grey
Mounting distance relating to metal surfaces recommended minimum	0 mm	0 mm	0 mm
Supply voltage, current consumption, power loss			
Supply voltage			
• at DC Rated value	24 V	24 V	24 V
• at DC	20 ... 30 V	20 ... 30 V	20 ... 30 V
Consumed current at DC at 24 V			
• typical	0.37 A	0.37 A	0.37 A
• maximum	2 A	2 A	2 A
Permitted ambient conditions			
Ambient temperature			
• during operation	-25 ... +55 °C	-25 ... +55 °C	-25 ... +55 °C
• during storage	-40 ... +85 °C	-40 ... +85 °C	-40 ... +85 °C
• during transport	-40 ... +85 °C	-40 ... +85 °C	-40 ... +85 °C
Ambient condition for operation	With operating temperature below -20 °C: Warming-up time at least 10 minutes	With operating temperature below -20 °C: Warming-up time at least 10 minutes	With operating temperature below -20 °C: Warming-up time at least 10 minutes
Protection class IP	IP30	IP30	IP30
Shock resistance	EN 60068-2-27	EN 60068-2-27	EN 60068-2-27
Shock, max. permissible	30 m/s ²	30 m/s ²	30 m/s ²
Vibration according to	EN 60068-2-6	EN 60068-2-6	EN 60068-2-6
Vibration, max. permissible	30 m/s ²	30 m/s ²	30 m/s ²
Design, dimensions and weight			
Width	258 mm	258 mm	258 mm
Height	258 mm	258 mm	258 mm
Depth	80 mm	80 mm	80 mm
Net weight	2.4 kg	2.4 kg	2.4 kg
Mounting type	Vesa 100 with 4 x M4 screws, top-hat rail 35 mm, profile rail S7-300, S7-1200 or S7-1500	Vesa 100 with 4 x M4 screws, top-hat rail 35 mm, profile rail S7-300, S7-1200 or S7-1500	Vesa 100 with 4 x M4 screws, top-hat rail 35 mm, profile rail S7-300, S7-1200 or S7-1500
Cable length			
• of antenna cable minimum	1 m	1 m	1 m
• of antenna cable maximum	40 m	40 m	40 m
Product properties, functions, components general			
Display version	LED row with 6 LEDs	LED row with 6 LEDs	LED row with 6 LEDs
Product feature silicon-free	Yes	Yes	Yes
Standards, specifications, approvals			
Certificate of suitability	Wireless according to R&TTE guideline, CE, IEC 60950	Wireless according to FCC, IC (Canada), cULus	RaWireless according to CMIIT
MTBF	31 y	31 y	31 y
Accessories			
Accessories	up to 4 external antennas, set for mounting on top-hat rail or profile rail	up to 4 external antennas, set for mounting on top-hat rail or profile rail	up to 4 external antennas, set for mounting on top-hat rail or profile rail

RFID systems for the UHF range

SIMATIC RF600 readers

RF650R

Selection and ordering data

	Article No.
SIMATIC RF650R reader (ETSI) UHF RFID reader for frequencies from 865 to 868 MHz for connecting up to four external antennas, suitable for inclusion in IT systems via Ethernet/IP with TCP/IP.	6GT2811-6AB20-0AA0
SIMATIC RF650R reader (FCC) UHF RFID reader for frequencies from 902 to 928 MHz for connecting up to four external antennas, suitable for inclusion in IT systems via Ethernet/IP with TCP/IP.	6GT2811-6AB20-1AA0
SIMATIC RF650R reader (CMIIT) UHF RFID reader for frequencies from 920 to 925 MHz for connecting up to four external antennas, suitable for inclusion in IT systems via Ethernet/IP with TCP/IP.	6GT2811-6AB20-2AA0
Accessories	
Antennas For proper functioning of the SIMATIC RF650R Reader, we recommend using the following antennas: <ul style="list-style-type: none"> • RF620A (siehe page 3/45) • RF640A (siehe page 3/48) • RF642A (siehe page 3/48) • RF660A (siehe page 3/51) 	
DI/DO cable For the connection of digital sensors and actuators to SIMATIC RF650R. M12 connector on reader side, open stranded wires on sensor side. DI/DO cable, PUR material, black, shielded, M12, 12 x 0.14 mm ² , length 5 m	6GT2891-0CH50
	
Wide-range power supply Primary side: 100 ... 240 V AC, 120 ... 353 V DC, secondary side: 24 V DC, 3 A, with no-load protection, with continuous short-circuit protection <ul style="list-style-type: none"> • EU connector version • UK connector version • US connector version 	6GT2898-0AA00 6GT2898-0AA10 6GT2898-0AA20
Cable for wide-range power supply 24 V DC, PUR material, length 5 m.	6GT2891-0PH50
	
Cable for 24 V power supply 24 V DC, material PUR, trailable, length 5 m, open ends	6GT2891-4EH50
	

	Article No.
Ethernet connection <ul style="list-style-type: none"> • Ethernet cable RJ45 to RJ45, 10 m • Ethernet cable RJ45 to RJ45, trailable, metal connector, various lengths 	6XV1870-3QN10 6XV1871-5Bxxx
Set of protective caps To prevent contamination of unused connections, we recommend the use of protective caps. Contents: 3 protective caps for antenna connection, one protective cap for DI/DO connection, 2 protective caps for Ethernet connection.	6GT2898-4AA10
DIN rail mounting kit For mounting the reader on a DIN rail (35 mm) or mounting rail S7-300/S7-1500	6GT2890-0AB00
	

Dimensional drawings

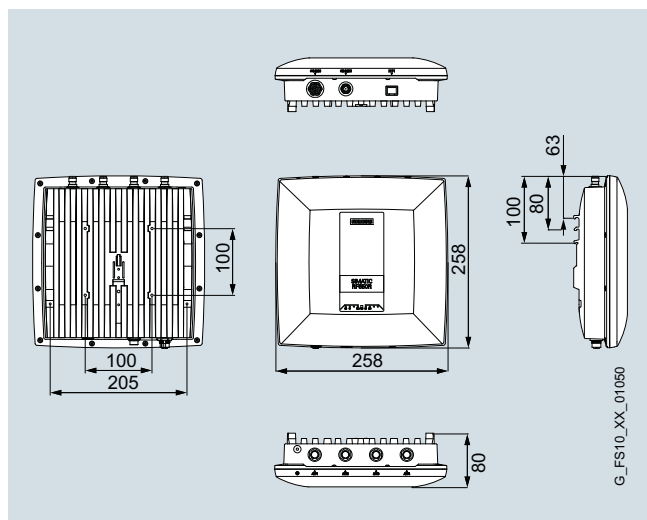

SIMATIC RF650R reader

G_FS10_XX_01050

Overview



The high-performance SIMATIC RF680R reader has four antenna connections that can be configured as required for individual read stations, or as gates. The high radiated power of up to 2 W ERP / 4 W EIRP (dependent on antenna and cable) permits long ranges of up to 8 m in portal applications.

The integrated processing logic of the reader enables numerous functions of the higher-level software layers to be executed in the device itself. If necessary, the digital outputs for signaling functions are automatically controlled.

The advantage of the SIMATIC RF680R is that its intelligence considerably reduces the cost for additional software modules (RFID middleware).

The configuration, commissioning and diagnosis is performed via an easy-to-use Web interface that can be operated with a standard Internet browser. Access to the user interface data is also possible via the TIA Portal.

The reader supports commissioning, such as the orientation of the antenna(s), or determining the radiant power required by means of corresponding software tools and of the extended LED display.

A variety of diagnostic displays, such as the live radio signal diagram or the diagnostic logbook considerably simplifies and speeds up troubleshooting.

Data communication in the RF680R is executed either via an XML protocol with TCP/IP or via an S7 protocol via PROFIBUS. The reader can be operated with PROFIBUS via the communication module ASM 456. Two Ethernet interfaces are available for data and diagnostics, one of which has PROFINET capability. The digital inputs and outputs (DI/DO) are used for simple process interfacing (sensors, actuators). The digital I/Os can be mapped directly into the IO image of a SIMATIC controller.

All antennas of the RF600 series are supported.

Note:

If the reader is used together with the ASM 456 communication module, be aware that only one reader can be connected to this communication module at a time. Two connected readers would exceed the maximum permissible power consumption.

Application

The stationary SIMATIC RF680R reader is ideal for applications in production, production-level logistics, distribution, supply chain management, asset management, service processes or material flow control.

The SIMATIC RF680R supports the established EPCglobal Class 1, Gen 2 standard and is offered in three versions: compliant with ETSI for Europe, FCC for USA/Canada, and CMIIT for China.

Technical specifications

	6GT2811-6AA10-0AA0	6GT2811-6AA10-1AA0	6GT2811-6AA10-2AA0
Article number	6GT2811-6AA10-0AA0	6GT2811-6AA10-1AA0	6GT2811-6AA10-2AA0
Product type designation	RF680R ETSI reader	RF680R FCC reader	RF680R CMIIT reader
Suitability for operation	RF600 transponder, for direct connection to Ethernet/PROFINET or PROFIBUS via communication module	RF600 transponder, for direct connection to Ethernet/PROFINET or PROFIBUS via communication module	RF600 transponder, for direct connection to Ethernet/PROFINET or PROFIBUS via communication module
Wireless frequencies			
Operating frequency	865 ... 868 MHz	902 ... 928 MHz	920 ... 925 MHz
Transmit power	3 ... 2 000 mW	3 ... 2 000 mW	3 ... 2 000 mW
Effective radiant power			
• for each external antenna maximum	2 000 mW		2 000 mW
Equivalent isotropically radiated power			
• for each external antenna maximum		4 000 mW	

RFID systems for the UHF range

SIMATIC RF600 readers

RF680R

Article number	6GT2811-6AA10-0AA0	6GT2811-6AA10-1AA0	6GT2811-6AA10-2AA0
Product type designation	RF680R ETSI reader	RF680R FCC reader	RF680R CMIIT reader
Electrical data			
Range maximum	8 m; Observe system manual RF600: Over-reaches are possible, range is dependent on transponder type: observe http://support.automation.siemens.com/WW/view/en/67384964	8 m; Observe system manual RF600: Over-reaches are possible, range is dependent on transponder type: observe	8 m; Observe system manual RF600: Over-reaches are possible, range is dependent on transponder type: observe
Protocol with radio transmission	EPCglobal Class 1 Gen 2 / ISO 18000-6B/-6C	EPCglobal Class 1 Gen 2 / ISO 18000-6B/-6C	EPCglobal Class 1 Gen 2 / ISO 18000-6B/-6C
Transfer rate with radio transmission maximum	300 kbit/s	300 kbit/s	300 kbit/s
Product feature multitag-capable	Yes	Yes	Yes
Transmission time for user data			
• for write access per byte typical	2 ms	2 ms	2 ms
• for read access per byte typical	0.15 ms	0.15 ms	0.15 ms
Interfaces			
Number of external antennas	4	4	4
Standard for interfaces for communication	Ethernet/PROFINET, RS422	Ethernet/PROFINET, RS422	Ethernet/PROFINET, RS422
Type of electrical connection			
• for external antenna(s)	RP-TNC	RP-TNC	RP-TNC
• for supply voltage	M12, 8-pin, connector	M12, 8-pin, connector	M12, 8-pin, connector
• for communications interface	2 x M12 4-pin D-coded, M12 8-pin (RS422)	2 x M12 4-pin D-coded, M12 8-pin (RS422)	2 x M12 4-pin D-coded, M12 8-pin (RS422)
• at the digital inputs/outputs	M12, 12-pin, female connector	M12, 12-pin, female connector	M12, 12-pin, female connector
Number of digital inputs	4	4	4
Number of digital outputs	4	4	4
Mechanical data			
Material	Aluminum, Pocan	Aluminum, Pocan	Aluminum, Pocan
Color	silver, TI-Grey	silver, TI-Grey	silver, TI-Grey
Mounting distance relating to metal surfaces recommended minimum	0 mm	0 mm	0 mm
Supply voltage, current consumption, power loss			
Supply voltage			
• at DC Rated value	24 V	24 V	24 V
• at DC	20 ... 30 V	20 ... 30 V	20 ... 30 V
Consumed current at DC at 24 V			
• typical	0.38 A	0.38 A	0.38 A
• maximum	2 A	2 A	2 A
Permitted ambient conditions			
Ambient temperature			
• during operation	-25 ... +55 °C	-25 ... +55 °C	-25 ... +55 °C
• during storage	-40 ... +85 °C	-40 ... +85 °C	-40 ... +85 °C
• during transport	-40 ... +85 °C	-40 ... +85 °C	-40 ... +85 °C
Ambient condition for operation	With operating temperature below -20 °C: Warming-up time at least 10 minutes	With operating temperature below -20 °C: Warming-up time at least 10 minutes	With operating temperature below -20 °C: Warming-up time at least 10 minutes
Protection class IP	IP65	IP65	IP65
Shock resistance	EN 60068-2-27	EN 60068-2-27	EN 60068-2-27
Shock, max. permissible	30 m/s ²	30 m/s ²	30 m/s ²
Vibration according to	EN 60068-2-6	EN 60068-2-6	EN 60068-2-6
Vibration, max. permissible	30 m/s ²	30 m/s ²	30 m/s ²

RFID systems for the UHF range

SIMATIC RF600 readers

RF680R



Article number	6GT2811-6AA10-0AA0	6GT2811-6AA10-1AA0	6GT2811-6AA10-2AA0
Product type designation	RF680R ETSI reader	RF680R FCC reader	RF680R CMIIT reader
Design, dimensions and weight			
Width	258 mm	258 mm	258 mm
Height	258 mm	258 mm	258 mm
Depth	80 mm	80 mm	80 mm
Net weight	2.4 kg	2.4 kg	2.4 kg
Mounting type	Vesa 100 with 4 x M4 screws, top-hat rail 35 mm, profile rail S7-300, S7-1200 or S7-1500	Vesa 100 with 4 x M4 screws, top-hat rail 35 mm, profile rail S7-300, S7-1200 or S7-1500	Vesa 100 with 4 x M4 screws, top-hat rail 35 mm, profile rail S7-300, S7-1200 or S7-1500
Cable length			
• of antenna cable minimum	1 m	1 m	1 m
• of antenna cable maximum	40 m	40 m	40 m
Product properties, functions, components general			
Display version	two LED rows with 8 and 9 LEDs	two LED rows with 8 and 9 LEDs	two LED rows with 8 and 9 LEDs
Product feature silicon-free	Yes	Yes	Yes
Standards, specifications, approvals			
Certificate of suitability	Wireless according to R&TTE guideline, CE, IEC 60950	Wireless according to FCC, IC (Canada), cULus	RaWireless according to CMIIT
MTBF	28 y	28 y	28 y
Accessories			
Accessories	up to 4 external antennas, set for mounting on top-hat rail or profile rail	up to 4 external antennas, set for mounting on top-hat rail or profile rail	up to 4 external antennas, set for mounting on top-hat rail or profile rail



RFID systems for the UHF range

SIMATIC RF600 readers

RF680R

Selection and ordering data

	Article No.
SIMATIC RF680R reader (ETSI) UHF RFID reader for frequencies from 865 to 868 MHz for connecting up to four external antennas, suitable for inclusion in IT systems and automation systems via Ethernet with TCP/IP and XML protocol or PROFINET.	6GT2811-6AA10-0AA0
SIMATIC RF680R reader (FCC) UHF RFID reader for frequencies from 902 to 928 MHz for connecting up to four external antennas, suitable for inclusion in IT systems and automation systems via Ethernet with TCP/IP and XML protocol or PROFINET.	6GT2811-6AA10-1AA0
SIMATIC RF680R reader (CMIIT) UHF RFID reader for frequencies from 920 to 925 MHz for connecting up to four external antennas, suitable for inclusion in IT and automation systems via Ethernet with TCP/IP and XML protocol or PROFINET.	6GT2811-6AA10-2AA0
Accessories	
Antennas	
For proper functioning of the SIMATIC RF680R Reader, we recommend using the following antennas: <ul style="list-style-type: none"> RF620A (see page 3/45) RF640A (see page 3/48) RF642A (see page 3/48) RF660A (see page 3/51) 	
DI/DO cable For the connection of digital sensors and actuators to SIMATIC RF680R. M12 connector on reader side, open stranded wires on sensor side. DI/DO cable, PUR material, black, shielded, M12, 12 x 0.14 mm ² , length 5 m	6GT2891-0CH50
	
Wide-range power supply Primary side: 100 ... 240 V AC, 120 ... 353 V DC, secondary side: 24 V DC, 3 A, with no-load protection, with continuous short-circuit protection <ul style="list-style-type: none"> EU connector version UK connector version US connector version 	6GT2898-0AA00 6GT2898-0AA10 6GT2898-0AA20
Cable for wide-range power supply 24 V DC, PUR material, length 5 m.	6GT2891-0PH50
	
Cable for 24 V power supply 24 V DC, material PUR, trailable, length 5 m, open ends	6GT2891-4EH50
	

	Article No.
Ethernet connection <ul style="list-style-type: none"> Ethernet cable M12 / RJ45, 5 m, RJ45 plug, obliquely angled, trailable 	6XV1871-5TH50
<ul style="list-style-type: none"> Ethernet cable M12 / M12, 5 m, trailable. 	6XV1870-8AH50
Set of protective caps Unused connections must be fitted with a protective cap to ensure the IP65 safety class. Contents: 3 protective caps for antenna connection, one protective cap for DI/DO connection, 2 protective caps for Ethernet connection.	6GT2898-4AA10
DIN rail mounting kit For mounting the reader on a DIN rail (35 mm) or mounting rail S7-300/S7-1500	6GT2890-0AB00
	

Dimensional drawings

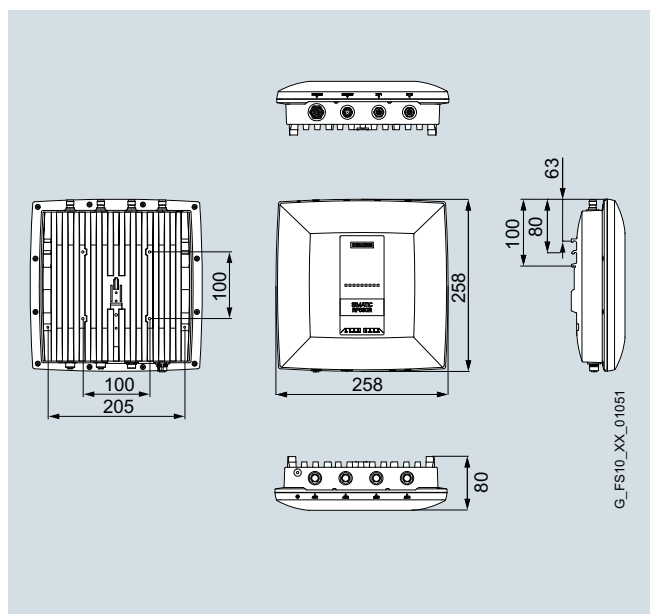

SIMATIC RF680R reader

Overview



The high-performance SIMATIC RF685R reader has a built-in adaptive antenna and a connection for an external antenna. This enables single reading stations with one or two antennas or two logical reading stations to be implemented for reading on conveyor systems. The high radiated power of up to 2 W ERP / 4 W EIRP (dependent on antenna and cable) permits long ranges. The high degree of protection (IP65) of the overall system enables problem-free use, even under the most difficult environmental conditions.

One special feature of the RF685R is the integrated adaptive antenna. Thanks to their variable polarization, they can achieve high reading rates, even in areas with poor radio reception. In addition, project planning and spare parts inventory management are considerably simplified. For individual reading points along a production line, the RF685R is the ideal choice of device.

Application

The SIMATIC RF685R stationary UHF reader is ideally suited for applications along a production line or for reading points that can be implemented with two antennas at maximum.

The integrated processing logic of the reader enables numerous functions of the higher-level software layers to be executed in the device itself. If necessary, the digital outputs for signaling functions are automatically controlled. The advantage of the SIMATIC RF685R is that its intelligence considerably reduces the cost for additional software modules (RFID middleware). Configuration, commissioning and diagnosis is performed via an easy-to-use Web interface that can be operated with a standard Internet browser. Access to the user interface data is also possible via the TIA Portal. The reader supports commissioning, such as the orientation of the antenna(s), or determining the radiant power required by means of corresponding software tools and the extended LED display.

A variety of diagnostic displays, such as the live radio signal diagram or the diagnostic logbook considerably simplifies and speeds up troubleshooting.

Data communication in the RF685R is executed either via an XML protocol with TCP/IP or via an S7 protocol via Profinet. Two Ethernet interfaces are available for data and diagnostics, of which one has Profinet capability.

The digital inputs and outputs (DI/DO) are used for simple process interfacing (sensors, actuators). The digital I/Os can be mapped directly into the IO image of a SIMATIC controller.

All antennas of the RF600 series are supported.

Note:

If the reader is used together with the ASM 456 communication module, be aware that only one reader can be connected to this communication module at a time. Two connected readers would exceed the maximum permissible power consumption.

RFID systems for the UHF range

SIMATIC RF600 readers

RF685R

Technical specifications

Article number	6GT2811-6CA10-0AA0	6GT2811-6CA10-1AA0	6GT2811-6CA10-2AA0
Product type designation	RF685R CMIIT reader	RF685R FCC reader	RF685R ETSI reader
Suitability for operation	RF600 transponder, for direct connection to Ethernet/PROFINET or PROFIBUS via communication module	RF600 transponder, for direct connection to Ethernet/PROFINET or PROFIBUS via communication module	RF600 transponder, for direct connection to Ethernet/PROFINET or PROFIBUS via communication module
Wireless frequencies			
Operating frequency	865 ... 868 MHz	902 ... 928 MHz	920 ... 925 MHz
Transmit power	3 ... 2 000 mW	3 ... 2 000 mW	3 ... 2 000 mW
Effective radiated power			
• for each external antenna maximum	2 000 mW		2 000 mW
• minimum	10 mW		10 mW
• maximum	2 000 mW		2 000 mW
Equivalent isotropically radiated power			
• for each external antenna maximum		4 000 mW	
• minimum		10 mW	
• maximum		4 000 mW	
Electrical data			
Range maximum	8 m; Observe system manual RF600: Overreaches are possible, range is dependent on transponder type: observe http://support.automation.siemens.com/WW/view/en/67384964	8 m; Observe system manual RF600: Overreaches are possible, range is dependent on transponder type: observe	8 m; Observe system manual RF600: Overreaches are possible, range is dependent on transponder type: observe
Protocol with radio transmission	EPCglobal Class 1 Gen 2 / ISO 18000-6B/-6C	EPCglobal Class 1 Gen 2 / ISO 18000-6B/-6C	EPCglobal Class 1 Gen 2 / ISO 18000-6B/-6C
Transfer rate with radio transmission maximum	300 kbit/s	300 kbit/s	300 kbit/s
Product feature multitag-capable	Yes	Yes	Yes
Polarization	linear, circular, auto	linear, circular, auto	linear, circular, auto
Transmission time for user data			
• for write access per byte typical	2 ms	2 ms	2 ms
• for read access per byte typical	0.15 ms	0.15 ms	0.15 ms
Interfaces			
Number of external antennas	1	1	1
Standard for interfaces for communication	Ethernet/PROFINET, RS422	Ethernet/PROFINET, RS422	Ethernet/PROFINET, RS422
Type of electrical connection			
• for external antenna(s)	RP-TNC	RP-TNC	RP-TNC
• for supply voltage	M12, 8-pin, connector	M12, 8-pin, connector	M12, 8-pin, connector
• for communications interface	2 x M12 4-pin D-coded, M12 8-pin (RS422)	2 x M12 4-pin D-coded, M12 8-pin (RS422)	2 x M12 4-pin D-coded, M12 8-pin (RS422)
• at the digital inputs/outputs	M12, 12-pin, female connector	M12, 12-pin, female connector	M12, 12-pin, female connector
Number of digital inputs	4	4	4
Number of digital outputs	4	4	4
Mechanical data			
Material	Aluminum, Poca	Aluminum, Poca	Aluminum, Poca
Color	silver, TI-Grey	silver, TI-Grey	silver, TI-Grey
Mounting distance relating to metal surfaces recommended minimum	0 mm	0 mm	0 mm
Supply voltage, current consumption, power loss			
Supply voltage			
• at DC Rated value	24 V	24 V	24 V
• at DC	20 ... 30 V	20 ... 30 V	20 ... 30 V
Consumed current at DC at 24 V			
• typical	0.38 A	0.38 A	0.38 A
• maximum	2 A	2 A	2 A

RFID systems for the UHF range

SIMATIC RF600 readers

RF685R







Article number	6GT2811-6CA10-0AA0	6GT2811-6CA10-1AA0	6GT2811-6CA10-2AA0
Product type designation	RF685R CMIIT reader	RF685R FCC reader	RF685R ETSI reader
Permitted ambient conditions			
Ambient temperature			
• during operation	-25 ... +55 °C	-25 ... +55 °C	-25 ... +55 °C
• during storage	-40 ... +85 °C	-40 ... +85 °C	-40 ... +85 °C
• during transport	-40 ... +85 °C	-40 ... +85 °C	-40 ... +85 °C
Ambient condition for operation	With operating temperature below -20 °C: Warming-up time at least 10 minutes	With operating temperature below -20 °C: Warming-up time at least 10 minutes	With operating temperature below -20 °C: Warming-up time at least 10 minutes
Protection class IP	IP65	IP65	IP65
Shock resistance	EN 60068-2-27	EN 60068-2-27	EN 60068-2-27
Shock, max. permissible	30 m/s ²	30 m/s ²	30 m/s ²
Vibration according to	EN 60068-2-6	EN 60068-2-6	EN 60068-2-6
Vibration, max. permissible	30 m/s ²	30 m/s ²	30 m/s ²
Design, dimensions and weight			
Width	258 mm	258 mm	258 mm
Height	258 mm	258 mm	258 mm
Depth	80 mm	80 mm	80 mm
Net weight	2.47 kg	2.47 kg	2.47 kg
Mounting type	Vesa 100 with 4 x M4 screws, top-hat rail 35 mm, profile rail S7-300, S7-1200 or S7-1500	Vesa 100 with 4 x M4 screws, top-hat rail 35 mm, profile rail S7-300, S7-1200 or S7-1500	Vesa 100 with 4 x M4 screws, top-hat rail 35 mm, profile rail S7-300, S7-1200 or S7-1500
Cable length			
• of antenna cable minimum	1 m	1 m	1 m
• of antenna cable maximum	40 m	40 m	40 m
Product properties, functions, components general			
Display version	two LED rows with 8 and 9 LEDs	two LED rows with 8 and 9 LEDs	two LED rows with 8 and 9 LEDs
Product feature silicon-free	Yes	Yes	Yes
Standards, specifications, approvals			
Certificate of suitability	Wireless according to R&TTE guideline, CE, IEC 60950	Wireless according to FCC, IC (Canada), cULus	RaWireless according to CMIIT
MTBF	29 y	29 y	29 y
Accessories			
Accessories	one external antenna, set for mounting on top-hat rail or profile rail	one external antenna, set for mounting on top-hat rail or profile rail	one external antenna, set for mounting on top-hat rail or profile rail

RFID systems for the UHF range

SIMATIC RF600 readers

RF685R

Selection and ordering data

	Article No.		Article No.
SIMATIC RF685R reader (ETSI) UHF RFID reader for frequencies from 865 to 868 MHz with integrated antenna. Connection for one external antenna is provided. Suitable for inclusion in IT and automation systems via Ethernet with TCP/IP and XML protocol or PROFINET.	6GT2811-6CA10-0AA0	Ethernet connection <ul style="list-style-type: none"> Ethernet cable M12 / RJ45, 5 m, RJ45 plug, obliquely angled, trailable 	6XV1871-5TH50
SIMATIC RF685R reader (FCC) UHF RFID reader for frequencies from 902 to 928 MHz with integrated antenna. Connection for one external antenna is provided. Suitable for inclusion in IT and automation systems via Ethernet with TCP/IP and XML protocol or PROFINET.	6GT2811-6CA10-1AA0	<ul style="list-style-type: none"> Ethernet cable M12 / M12, 5 m, trailable 	6XV1870-8AH50
SIMATIC RF685R reader (CMIIT) UHF RFID reader for frequencies from 920 to 925 MHz with integrated antenna. Connection for one external antenna is provided. Suitable for inclusion in IT and automation systems via Ethernet with TCP/IP and XML protocol or PROFINET.	6GT2811-6CA10-2AA0	Set of protective caps Unused connections must be fitted with a protective cap to ensure the IP65 safety class. Contents: 3 protective caps for antenna connection, one protective cap for DI/DO connection, 2 protective caps for Ethernet connection.	6GT2898-4AA10
Accessories Antennas For proper functioning of the SIMATIC RF685R Reader, we recommend using the following antennas: <ul style="list-style-type: none"> RF620A (see page 3/45) RF640A (see page 3/48) RF642A (see page 3/48) RF660A (see page 3/51) 		DIN rail mounting kit For mounting the reader on a DIN rail (35 mm) or mounting rail S7-300/S7-1500 	6GT2890-0AB00
DI/DO cable For the connection of digital sensors and actuators to SIMATIC RF685R. M12 connector on reader side, open stranded wires on sensor side. DI/DO cable, PUR material, black, shielded, M12, 12 x 0.14 mm ² , length 5 m 	6GT2891-0CH50		
Wide-range power supply Primary side: 100 ... 240 V AC, 120 ... 353 V DC, secondary side: 24 V DC, 3 A, with no-load protection, with continuous short-circuit protection <ul style="list-style-type: none"> EU connector version UK connector version US connector version 	6GT2898-0AA00 6GT2898-0AA10 6GT2898-0AA20		
Cable for wide-range power supply 24 V DC, PUR material, length 5 m. 	6GT2891-0PH50		
Cable for 24 V power supply 24 V DC, material PUR, trailable, length 5 m, open ends 	6GT2891-4EH50		

Dimensional drawings

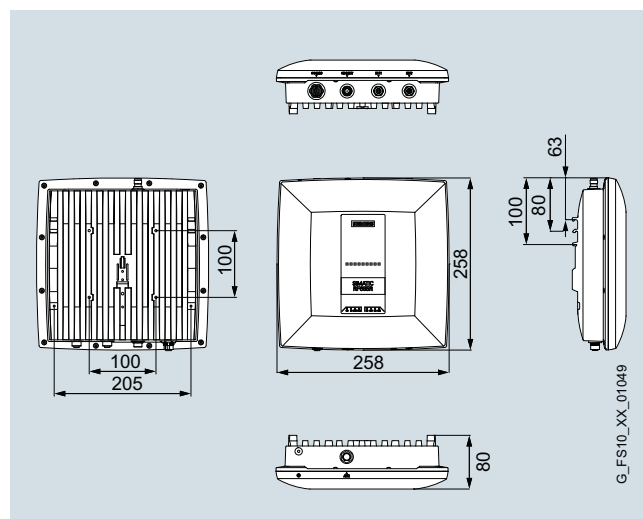

SIMATIC RF685R reader

Overview

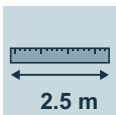

SIMATIC RF650M is a powerful and compact mobile RFID reader for applications in the field of production logistics, warehouse management, inventories and service. The device is also an important tool for the commissioning and testing of RFID systems. Thanks to the high transmit power, the RFID transponders can also be reliably detected at large distances.

Design

The SIMATIC RF650M handheld reader features a color touch display with a resolution of 240 x 320 pixels, rugged keypad and a large trigger button. This ensures reliable and user-friendly operation. To save space, users can fold down the RFID antenna.

The dimensions of just 147 x 60 x 39 mm mean that the device can easily be carried in a pocket. Its low weight of only 235 g including rechargeable battery enables the reader to be used for long periods without fatigue.

Function

The supplied and pre-installed RF600 software provides service and test functions for reading and writing the RF600 transponders and SmartLabels (compliant with ISO 18000-6C). Data that has been read can be saved in files. To locate objects that have been equipped with a transponder, the software offers a simple localization and search function.

Based on the operating system and communication standards (WIN CE), the device ensures easy integration in existing or planned IT networks or in the process infrastructure. For this purpose, various optional development tools for the PC (Software Development Kit) can be obtained directly from Nordic ID.

The read data can be forwarded to the IT infrastructure via the integrated WLAN or via USB or Ethernet port of the docking station.

Integration

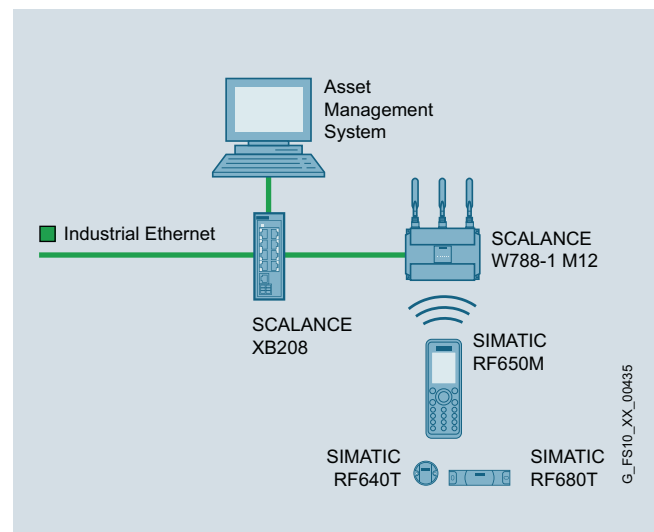

Mobile RFID data acquisition system connected via SCALANCE components

RFID systems for the UHF range

SIMATIC RF600 readers

RF650M mobile handheld terminal

Technical specifications

	6GT2813-0CA00	6GT2813-0CA10
Article number	6GT2813-0CA00	6GT2813-0CA10
Product type designation	RF650M ETSI mobile hand-held terminal	RF650M FCC mobile hand-held terminal
Suitability for operation	RF600 transponder	RF600 transponder
Range	2 500 mm, is dependent on transponder type	2 500 mm, is dependent on transponder type
Wireless frequencies		
Operating frequency	865.6 ... 867.6 MHz	902 ... 928 MHz
Effective radiant power	500 mW	
Equivalent isotropically radiated power		820 mW
Electrical data		
Protocol with radio transmission	EPCglobal Class 1 Gen 2 / ISO 18000-6C	EPCglobal Class 1 Gen 2 / ISO 18000-6C
Product feature multitag-capable	Yes	Yes
Polarization	Linear horizontal, vertical, automatic	Linear horizontal, vertical, automatic
Supply voltage, current consumption, power loss		
Type of current supply	Battery operation or mains operation	Battery operation or mains operation
Type of battery	Li-Polymer accumulator, replaceable	Li-Polymer accumulator, replaceable
Battery capacity	2.26 Ah	2.26 Ah
Operating period with standard battery typical	9 h	9 h
Permitted ambient conditions		
Ambient temperature		
• during operation	-20 ... +55 °C	-20 ... +55 °C
• during storage	-20 ... +60 °C	-20 ... +60 °C
Relative humidity at 25 °C without condensation during operation maximum	95 %	95 %
Height of fall maximum	1.5 m	1.5 m
Protection class IP	IP54	IP54
Design, dimensions and weight		
Width	60 mm	60 mm
Height	147 mm	147 mm
Depth	39 mm	39 mm
Net weight	0.24 kg	0.24 kg
Product properties, functions, components general		
Design of the display	QVGA color touch screen 2.2 inch, 240 x 320 pixels	QVGA color touch screen 2.2 inch, 240 x 320 pixels
Operator element version	Alphanumeric	Alphanumeric
Design of acoustic signaling element	Speakers	Speakers
Design of the interface	WLAN, USB and Ethernet via charging station	WLAN, USB and Ethernet via charging station
Storage capacity		
• of the RAM	256 Mibyte	256 Mibyte
• of the data and program memory	288 Mibyte	288 Mibyte
• of the data memory can be used	256 Mibyte	256 Mibyte
Product functions management, configuration		
Operating system pre-installed	Windows Embedded CE 6.0	Windows Embedded CE 6.0
Product function of the software	Record, process, search of ISO 18000-6C transponder	Record, process, search of ISO 18000-6C transponder
Type of programming	Programming with MS Visual Studio 2008 API for several programming languages available	Programming with MS Visual Studio 2008 API for several programming languages available
Standards, specifications, approvals		
Certificate of suitability	EMC: EN 55022, EN 301 489, safety: EN 60950, RF: EN 302 208	EMC: EN 55022, EN 301 489, safety: EN 60950, RF: EN 302 208, FCC Part 15
MTBF	43 y	43 y
Accessories		
Accessories	Charging/docking station with USB- and Ethernet interface, changeable accumulator Li-Po 2260 mAh / 3.7 V, also included: charging device 100-240 V	Charging/docking station with USB- and Ethernet interface, changeable accumulator Li-Po 2260 mAh / 3.7 V, also included: charging device 100-240 V

Selection and ordering data

	Article No.
SIMATIC RF650M (ETSI) mobile handheld terminal Basic unit, suitable for transponders conforming to EPCglobal Class 1 Gen 2 / ISO 18000-6C, incl. charger and battery. Frequency 865 ... 868 MHz (ETSI), standard software preinstalled.	6GT2813-0CA00
SIMATIC RF650M (FCC) mobile handheld terminal Basic unit, suitable for transponders conforming to EPCglobal Class 1 Gen 2 / ISO 18000-6C, incl. charger and battery. Frequency 902 ... 928 MHz (FCC), standard software preinstalled.	6GT2813-0CA10
Accessories	
Charging/docking station For one RF650M mobile reader and one spare battery, including Ethernet port, USB port and USB cable.	6GT2898-0BB00
	
Replacement battery for SIMATIC RF650M mobile handheld terminal	6GT2898-0CB00
DVD „RFID-Systeme Software & Documentation“	6GT2080-2AA20

Dimensional drawings

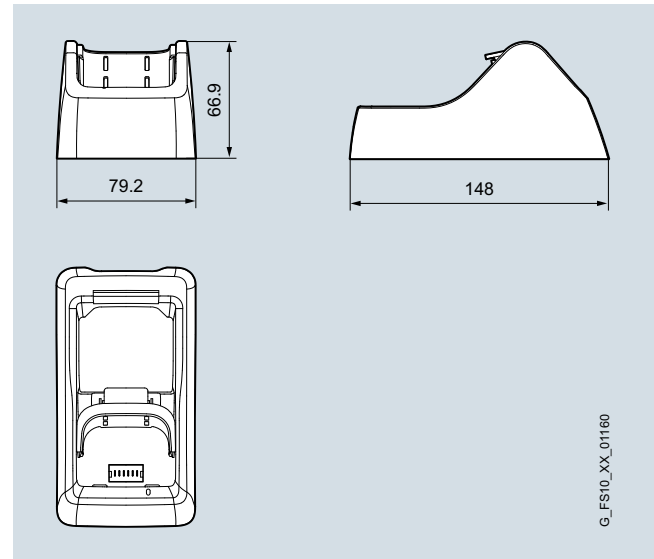

Charging/docking station for RF650M mobile handheld terminal





RFID systems for the UHF range

SIMATIC RF600 antennas

Introduction

Overview

SIMATIC RF600 UHF antennas are used in many different applications in production, material handling, and logistics. Thanks to their rugged design and high degree of protection, they are also suitable for harsh industrial environments.

Antenna	Features	Page	Antenna	Features	Page
RF620A 	Particularly compact antenna for applications in production, e.g. assembly lines or conveyor systems.	3/45	RF642A 	Compact antenna with linear polarization for strongly reflective environments.	3/48
RF640A 	Universal and compact standard antenna for wide ranges	3/48	RF660A 	Universal antenna with high degree of protection (IP67) for applications in production and logistics that require a greater range.	3/51

Overview

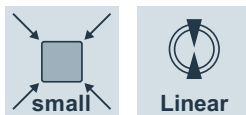

The SIMATIC RF620A antenna is characterized by an especially compact enclosure. It is particularly suitable for use in production, e.g. on assembly lines or track-guided conveyor systems. The effects of reflections and overshooting can be reliably reduced thanks to the linear polarization and high degree of signal attenuation.

The antenna can be operated with the UHF readers of the SIMATIC RF600 range.

Technical specifications

	6GT2812-1EA00	6GT2812-1EA01
Article number	6GT2812-1EA00	6GT2812-1EA01
Product type designation	RF620A, ETSI antenna	RF620A, FCC antenna
Suitability for operation	SIMATIC RF600	SIMATIC RF600
Wireless frequencies		
Transmission frequency	865 ... 868 MHz	902 ... 928 MHz
Electrical data		
Impedance	50 Ω	50 Ω
Polarization	Linear	Linear
Antenna gain compared to spherical radiator		
• with linear radiation	-5 dB	-5 dB
Standing wave ratio (VSWR) maximum	2	2
Radiating angle of the antenna		
• horizontal	100°	130°
• vertical	75°	105°
Type of electrical connection of the antenna	RP-TNC	RP-TNC
Design of plug-in connection	male	male
Mechanical data		
Material	PA 12	PA 12
Color	Pastel turquoise	Pastel turquoise
Tightening torque of the screw for securing the equipment maximum	2 Nm	2 Nm
Mounting distance		
• relating to metal surfaces recommended minimum	0 m	0 m
Permitted ambient conditions		
Ambient temperature		
• during operation	-20 ... +70 °C	-20 ... +70 °C
• during storage	-40 ... +85 °C	-40 ... +85 °C
• during transport	-40 ... +85 °C	-40 ... +85 °C
Protection class IP	IP67	IP67
Shock resistance	according to EN 60068-2-27	according to EN 60068-2-27
Shock acceleration	500 m/s ²	500 m/s ²
Schwingbeschleunigung	200 m/s ²	200 m/s ²

RFID systems for the UHF range

SIMATIC RF600 antennas

RF620A

Article number	6GT2812-1EA00	6GT2812-1EA01
Product type designation	RF620A, ETSI antenna	RF620A, FCC antenna
Design, dimensions and weight		
Width	75 mm	75 mm
Height	75 mm	75 mm
Depth	20 mm	20 mm
Net weight	100 g	100 g
Mounting type	2 screws M5	2 screws M5
Cable length of antenna cable	0 m	0 m
Product properties, functions, components general		
Product feature silicon-free	Yes	Yes
Standards, specifications, approvals		
Certificate of suitability	CE (ETSI EN 302208)	FCC (Title 47, Part 15.247), cULus
Accessories		
Accessories	Antenna cables 1 to 40 m	Antenna cables 1 to 40 m

Selection and ordering data

	Article No.		Article No.
SIMATIC RF620A (ETSI) compact antenna	6GT2812-1EA00	Accessories	
Linear polarized UHF antenna for frequency range 865 to 868 MHz.			
SIMATIC RF620A (FCC) compact antenna	6GT2812-1EA01	Note: To ensure optimal functioning of the antenna, it is recommended that a Siemens antenna cable is used.	
Linear polarized UHF antenna for frequency range 902 to 928 MHz.		Antenna cable	
		UV resistant, reverse TNC, UL certified, impedance 50 Ω	
		• Material: PE, halogen-free	
			
		- Length 1 m, Ø 5 mm, attenuation 0.5 dB	6GT2815-0BH10
		- Length 3 m, Ø 5 mm, attenuation 1 dB	6GT2815-0BH30
		- Length 10 m, Ø 5 mm, attenuation 4 dB	6GT2815-0BN10
		- Length 10 m, Ø 7.6 mm, attenuation 2 dB	6GT2815-1BN10
		- Length 20 m, Ø 7.6 mm, attenuation 4 dB	6GT2815-0BN20
		- Length 40 m, Ø 10.3 mm, attenuation 5 dB	6GT2815-0BN40
		• Material: PVC, Ø 5.5 mm, suitable for cable carriers	
		- 5 m long, 1.5 dB attenuation	6GT2815-2BH50
		- 15 m long, 4.5 dB attenuation	6GT2815-2BN15

Dimensional drawings

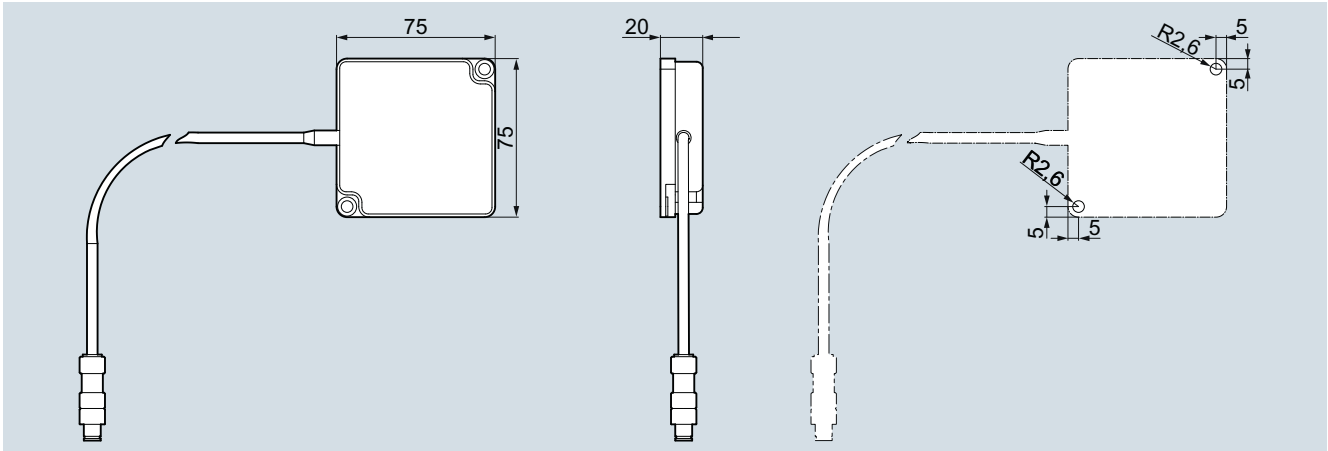

SIMATIC RF620A antenna

RFID systems for the UHF range

SIMATIC RF600 antennas

RF640A, RF642A

Overview



6GT2812-0GA08



Circular



6GT2812-1GA08



Linear

The SIMATIC RF640A/RF642A are rugged and compact antennas for industrial applications in production and logistics.

- The SIMATIC RF640A is a universal antenna for numerous applications. They are used, in particular, in applications where transponders in widely varying orientations have to be detected.
- The SIMATIC RF642A is, with its linear polarization, particularly suitable for severely metallic environments.

Both antennas can be used in Europe, the United States and China (broadband) and with the readers of the SIMATIC RF600 range.

Technical specifications

	6GT2812-0GA08	6GT2812-1GA08
Article number	6GT2812-0GA08	6GT2812-1GA08
Product type designation	RF640A antenna	RF642A antenna
Suitability for operation	SIMATIC RF600	SIMATIC RF600
Wireless frequencies		
Transmission frequency	865 ... 928 MHz	865 ... 928 MHz
Electrical data		
Impedance	50 Ω	50 Ω
Polarization	Circular	Linear
Antenna gain compared to spherical radiator		6 dB
• with linear radiation		
• with circular radiation	4 dB	
Standing wave ratio (VSWR) maximum	1.5	1.5
Radiating angle of the antenna		
• horizontal	80°	75°
• vertical	75°	70°
Type of electrical connection of the antenna	RP-TNC	RP-TNC
Design of plug-in connection	male	male
Mechanical data		
Material	PA 12	PA 12
Color	Pastel turquoise	Pastel turquoise
Tightening torque of the screw for securing the equipment maximum	2 Nm	2 Nm
Mounting distance		
• relating to metal surfaces recommended minimum	0 m	0 m

RFID systems for the UHF range



SIMATIC RF600 antennas

RF640A, RF642A

Article number	6GT2812-0GA08	6GT2812-1GA08
Product type designation	RF640A antenna	RF642A antenna
Permitted ambient conditions		
Ambient temperature		
• during operation	-25 ... +75 °C	-25 ... +75 °C
• during storage	-40 ... +85 °C	-40 ... +85 °C
• during transport	-40 ... +85 °C	-40 ... +85 °C
Protection class IP	IP65	IP65
Shock resistance	according to EN 60068-2-27	according to EN 60068-2-27
Shock acceleration	300 m/s ²	300 m/s ²
Vibrational acceleration	100 m/s ²	100 m/s ²
Design, dimensions and weight		
Width	185 mm	185 mm
Height	185 mm	185 mm
Depth	45 mm	45 mm
Net weight	600 g	600 g
Mounting type	4 screws M4 according to VESA 100, optional with articulated bracket by using antenna mounting kit	4 screws M4 according to VESA 100, optional with articulated bracket by using antenna mounting kit
Cable length of antenna cable	0 m	0 m
Product properties, functions, components general		
Product feature silicon-free	Yes	Yes
Standards, specifications, approvals		
Certificate of suitability	CE (according to R&TTE), FCC (Title 47, Part 15.247), cULus	CE (according to R&TTE), FCC (Title 47, Part 15.247), cULus
Accessories		
Accessories	Antenna cables 1 to 40 m, antenna mounting kit	Antenna cables 1 to 40 m, antenna mounting kit

3

Selection and ordering data

	Article No.		Article No.
SIMATIC RF640A	6GT2812-0GA08	<ul style="list-style-type: none"> Material: PVC, Ø 5.5 mm, suitable for cable carriers - 5 m long, 1.5 dB attenuation - 15 m long, 4.5 dB attenuation 	
Circular polarization antenna for UHF frequency 865 MHz to 928 MHz (ETSI, FCC, CMIIT).			6GT2815-2BH50
SIMATIC RF642A	6GT2812-1GA08		6GT2815-2BN15
Linear polarization antenna for UHF frequency 865 MHz to 928 MHz (ETSI, FCC, CMIIT).		Antenna mounting kit	6GT2890-0AA00
Accessories		For flexible mounting, with articulated bracket.	
Note:			
Antenna cable			
UV resistant, reverse TNC, UL certified, impedance 50 Ω			
• Material: PE, halogen-free			
			
- Length 1 m, Ø 5 mm, attenuation 0.5 dB	6GT2815-0BH10		
- Length 3 m, Ø 5 mm, attenuation 1 dB	6GT2815-0BH30		
- Length 10 m, Ø 5 mm, attenuation 4 dB	6GT2815-0BN10		
- Length 10 m, Ø 7.6 mm, attenuation 2 dB	6GT2815-1BN10		
- Length 20 m, Ø 7.6 mm, attenuation 4 dB	6GT2815-0BN20		
- Length 40 m, Ø 10.3 mm, attenuation 5 dB	6GT2815-0BN40		

RFID systems for the UHF range

SIMATIC RF600 antennas

RF640A, RF642A

Dimensional drawings

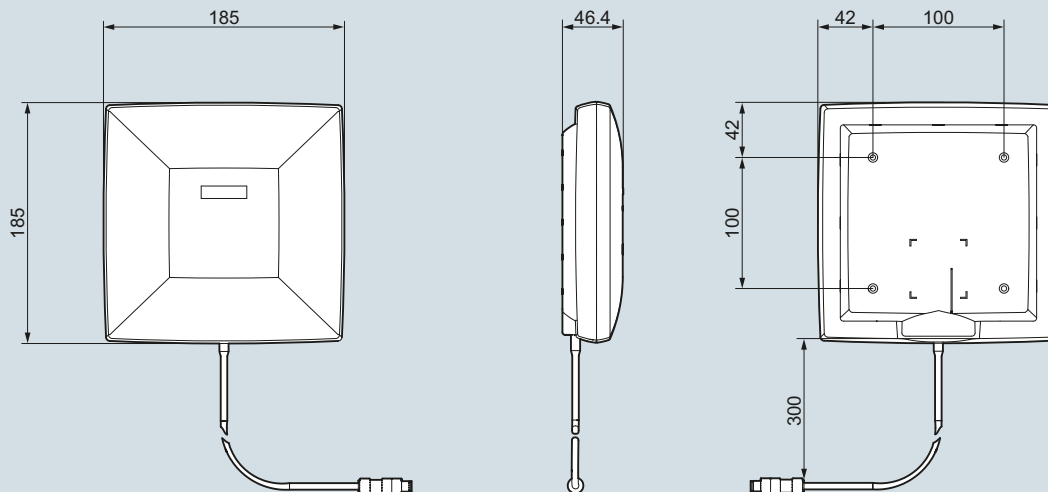

SIMATIC RF640A, RF642A antennas

Overview



Circular

The universal UHF antenna RF660A is suitable for numerous applications in production and logistics that require a greater range. Typical applications are conveyor systems in material handling and logistics systems as well as gates, e.g. in the incoming goods department.

Thanks to its rugged design and high degree of protection, the SIMATIC RF660A antenna is also suitable for harsh industrial environments. The antenna can be operated with the readers of the SIMATIC RF600 range.

Technical specifications

	6GT2812-0AA00	6GT2812-0AA01
Article number	RF660A 865-868 EU antenna	RF660A 902-928 US antenna
Product type designation	SIMATIC RF600	SIMATIC RF600
Suitability for operation		
Wireless frequencies		
Transmission frequency	865 ... 868 MHz	902 ... 928 MHz
Electrical data		
Impedance	50 Ω	50 Ω
Polarization	Circular	Circular
Antenna gain compared to spherical radiator		
• with circular radiation	7 dB	6 dB
Standing wave ratio (VSWR) maximum	2	2
Radiating angle of the antenna		
• horizontal	60°	70°
• vertical	60°	70°
Type of electrical connection of the antenna	RP-TNC	RP-TNC
Design of plug-in connection	male	male
Mechanical data		
Material	PA 12	PA 12
Color	Pastel turquoise	Pastel turquoise
Mounting distance		
• relating to metal surfaces recommended minimum	0 m	0 m
Permitted ambient conditions		
Ambient temperature		
• during operation	-25 ... +75 °C	-25 ... +75 °C
• during storage	-40 ... +85 °C	-40 ... +85 °C
• during transport	-40 ... +85 °C	-40 ... +85 °C
Protection class IP	IP67	IP67
Shock resistance	according to EN 60068-2-27	according to EN 60068-2-27
Shock acceleration	300 m/s ²	300 m/s ²
Vibrational acceleration	1 m/s ²	1 m/s ²



RFID systems for the UHF range

SIMATIC RF600 antennas

RF660A

Article number	6GT2812-0AA00	6GT2812-0AA01
Product type designation	RF660A 865-868 EU antenna	RF660A 902-928 US antenna
Design, dimensions and weight		
Width	313 mm	313 mm
Height	313 mm	313 mm
Depth	80 mm	80 mm
Net weight	1.6 kg	1.6 kg
Mounting type	4 screws M4 according to VESA 100, optional with articulated bracket by using antenna mounting kit	4 screws M4 according to VESA 100, optional with articulated bracket by using antenna mounting kit
Cable length of antenna cable	0 m	0 m
Product properties, functions, components general		
Product feature silicon-free	Yes	Yes
Standards, specifications, approvals		
Certificate of suitability	CE (ETSI EN 302208)	FCC (Title 47, Part 15.247), cULus
Accessories		
Accessories	Antenna cables 1 to 40 m, antenna mounting kit	Antenna cables 1 to 40 m, antenna mounting kit

Selection and ordering data

	Article No.		Article No.
SIMATIC RF660A (ETSI) antenna	6GT2812-0AA00	Accessories	
Circular polarized UHF antenna for frequency range 865 to 868 MHz.			
SIMATIC RF660A (FCC) antenna	6GT2812-0AA01	Note:	
Circular polarized UHF antenna for frequency range 902 to 928 MHz.		To ensure proper functioning of the SIMATIC RF660A antenna, it is recommended that Siemens antenna cables are used..	
		Antenna cable	
		UV resistant, reverse TNC, UL certified, impedance 50 Ω	
		• Material: PE, halogen-free	
			
		- Length 3 m, Ø 5 mm, attenuation 1 dB	6GT2815-0BH10
		- Length 10 m, Ø 5 mm, attenuation 4 dB	6GT2815-0BH30
		- Length 10 m, Ø 7.6 mm, attenuation 2 dB	6GT2815-0BN10
		- Length 20 m, Ø 7.6 mm, attenuation 4 dB	6GT2815-1BN10
		- Length 40 m, Ø 10.3 mm, attenuation 5 dB	6GT2815-0BN20
		- Length 3 m, Ø 5 mm, attenuation 1 dB	6GT2815-0BN40
		• Material: PVC, Ø 5.5 mm, suitable for cable carriers	
		- 5 m long, 1.5 dB attenuation	6GT2815-2BH50
		- 15 m long, 4.5 dB attenuation	6GT2815-2BN15
		Antenna mounting kit	6GT2890-0AA00
		For flexible mounting, with articulated bracket.	
			

Dimensional drawings

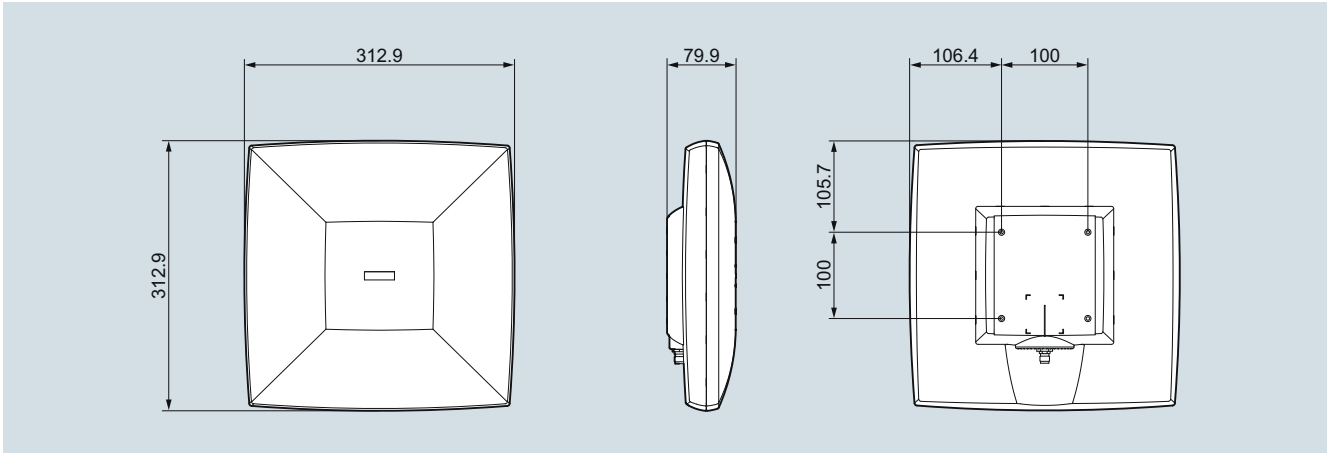

SIMATIC RF660A antenna

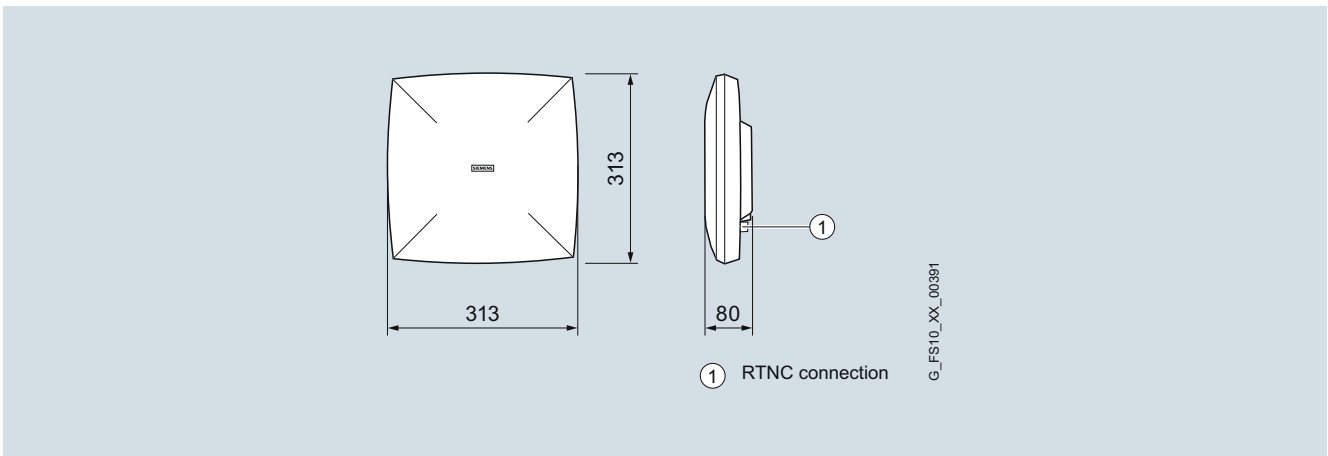

SIMATIC RF660A antenna, position of connection

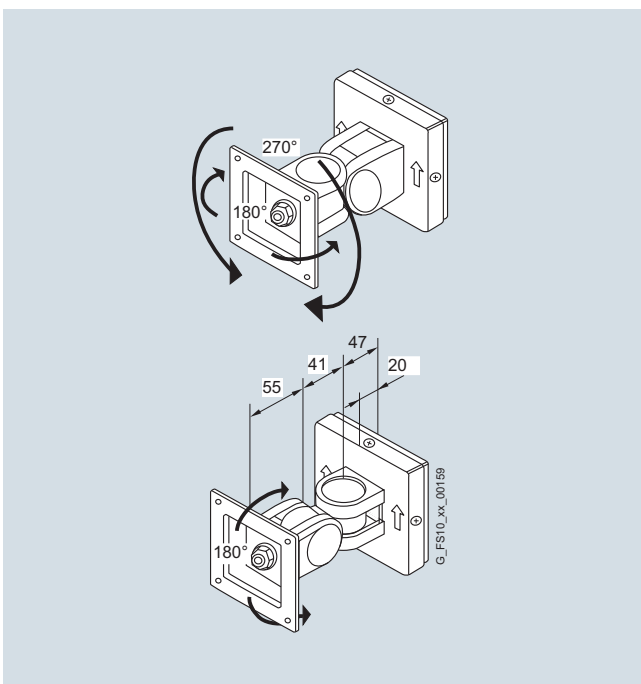

Antenna mounting kit

RFID systems for the UHF range

Notes

Optical identification

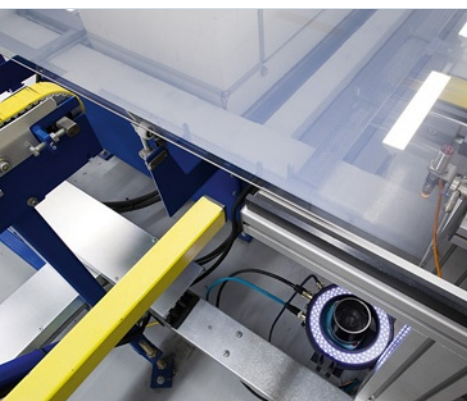

4/2

4/2

Optical identification

Introduction

4/6

4/11

4/6

4/32

Stationary code reading systems

MV420

MV440

Lenses

4/37

4/39

4/41

4/43

Handheld reading systems

MV320

MV325

MV340

4/45

4/45

Verification systems

Veri-Genius for MV440

4/50

4/50

Optical character recognition (OCR)

Text-Genius for MV440

4/54

4/54

Object recognition

Pat-Genius for MV440

Optical identification

Introduction

Overview

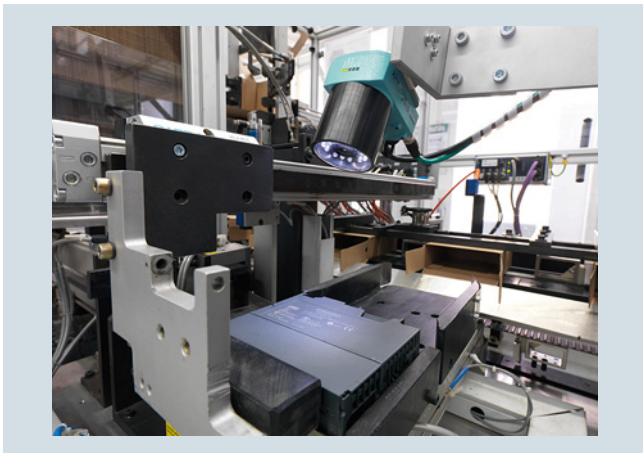

Optical readers – Reading and verification of 1D/2D codes

For state-of-the-art production systems, tracing products and parts with machine-readable identification is a central requirement. A unique coding system permits the planning and implementation of each and every step of production for every part manufactured as well as changes within the production process or in the materials used. Direct marking of products also allows the implementation of specified legal requirements for tracing production batches throughout the production system.

What is direct part marking (DPM)?

Direct part marking (DPM) is the application of a mark directly on the surface of a product without the use of a separate carrier material, such as an adhesive label. This makes it possible to identify products in production and trace them after delivery as well.

With so-called 2D codes a coding method is available that meets these user requirements. 2D codes consist of easy to implement, point-shaped basic elements. Laser and needle marking technologies are outstanding with regard to durability, marking speed and material independence. Despite mechanical deformations, e.g. with metallic work pieces, the 2D codes can still be read using 2D readers even after multiple processing steps. 2D codes also provide the advantage of being able to encode data in more limited spaces than comparable barcodes or plain text.

Benefits



- Clear identification of products and product parts
- Marking in accordance with international standards (e.g. ISO 29158).
- Direct part marking is the key technology for tracing products - low-cost, undetachable, and almost indestructible.
- Flexible and economic solutions thanks to the complete and scalable portfolio of powerful stationary optical readers.
- Simplified engineering, commissioning, diagnostics and maintenance through seamless integration into Totally Integrated Automation (TIA):
 - Integrated bus connection to an automation system, such as SIMATIC, SIMOTION or SINUMERIK via communication modules with PROFIBUS and PROFINET.
 - Easy S7 software integration based on ready-to-use function blocks.
 - Extensive status and diagnostic functions.
- Greater security of investment due to support of all standard matrix and barcodes.
- Openness due to connection possibilities to different bus systems from different manufacturers and PC environments via communication modules.

Integration

The product range of optical reading devices from Siemens

Stationary optical readers



Stationary optical SIMATIC MV440 and MV420 readers

The high-performance stationary optical readers are small, user-friendly devices for reading applications. The devices read various two-dimensional (2D) codes as well as one-dimensional (1D) barcodes. Optionally, function packages can be added to all SIMATIC MV440 devices using SIMATIC License Manager licenses. The following licenses are available for function expansion:

- Veri-Genius for measuring the marking quality
- Text-Genius for text recognition and
- Pat-Genius for object recognition

These optional function extensions can be selected and combined as required.

Optical handheld reading devices



SIMATIC MV320 optical handheld reading device



SIMATIC MV325 optical handheld reading device



SIMATIC MV340 optical handheld reader

The high-performance, high-resolution handheld readers are suitable for either two-dimensional (2D) data matrix codes and/or one-dimensional (1D) bar codes. The devices can communicate with a host computer via RS232, USB or Bluetooth, depending on the selected model.

Optical identification

Introduction

Verification systems

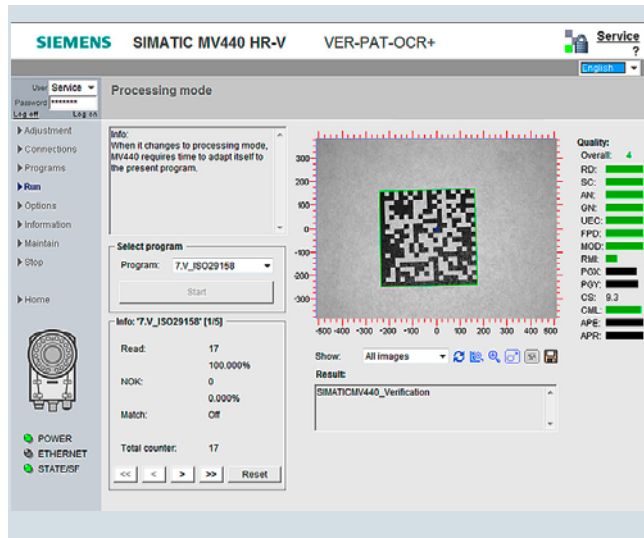

Graphical representation of the marking quality (verification) in the user interface

By using verification systems, the readability of marks is guaranteed throughout the entire production process, regardless of any possible contamination or when using different readers. Moreover, the marking can continue to be read after the production process throughout the lifespan of the product.

In addition to reading 1D barcodes and 2D matrix codes, SIMATIC MV440 can be expanded at any time with verification functionality using the "Veri-Genius" verification license. The license is supplied as a "Single License" on a USB stick and can be copied to the SIMATIC MV440 with the SIMATIC Automation License Manager (ALM) using a plug-in. The license is executable on any SIMATIC MV440 as of firmware version 4.0.

Optical character recognition

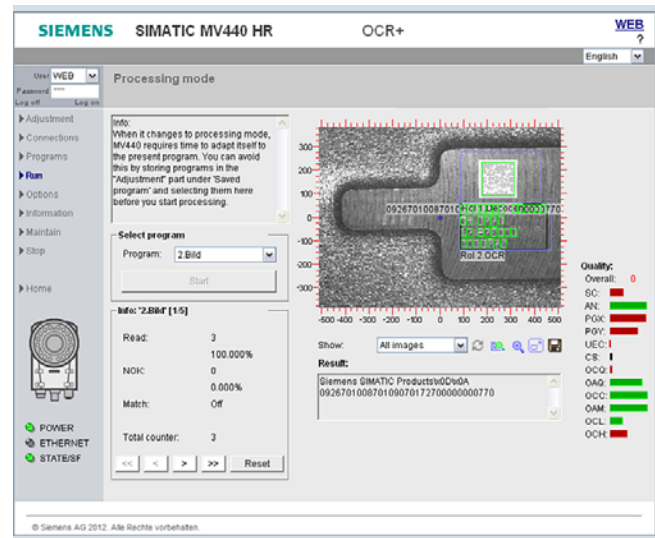

SIMATIC MV440 HR OCR

With the "Text-Genius" OCR license, SIMATIC MV440 can also be used for optical character recognition (OCR) in addition to reading 1D barcodes and 2D matrix codes. It is also possible to read and compare plain text and machine-readable code in the same image field.

Text recognition is available in two versions. "Text-Genius" is the text recognition version that is supplied ready-to-use for a specified character set (e.g. Polyfont). The "Text-Genius Plus" version is available for any character sets and project-specific character sets. In this version, the recognition can be adapted to numerous character sets and print images by means of project-specific training. Both text recognition licenses include the functionality of "PAT-Genius" for preparing (e.g. searching for the label position) text recognition.

The licenses are supplied as a "Single License" on a USB stick and can be copied to the device with the SIMATIC Automation License Manager (ALM) using a plug-in. The "Text-Genius" license is executable on any SIMATIC MV440 from firmware version 3.0 - the "Text-Genius Plus" license on any SIMATIC MV440 from firmware version 5.0

Object detection

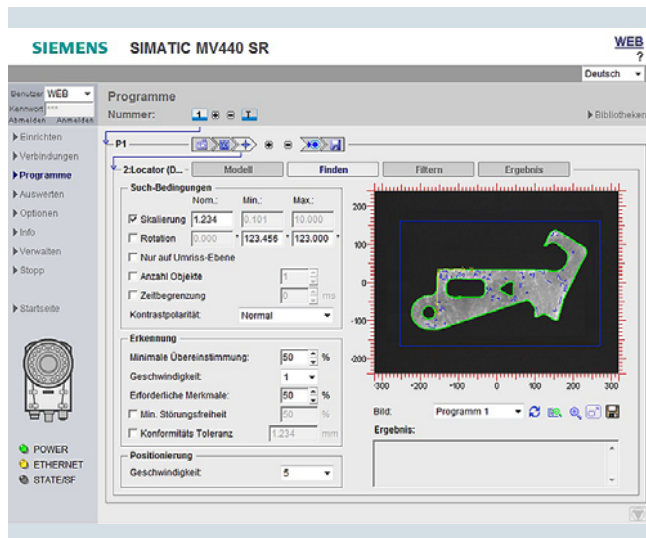

Object recognition with Pat-Genius

With the "Pat Genius" object recognition license, SIMATIC MV440 can also be used for object recognition (object classification, position detection, counting, etc.) in addition to reading 1D barcodes and 2D matrix codes. In addition, the functionality is possible in combination with text recognition, for example, thus enabling position control of a label and control of the labeling (reading and comparison) of plain text in an image field.

The license is supplied as a "Single License" on a USB stick and can be copied to the device with the SIMATIC Automation License Manager (ALM) using a plug-in. The license is executable on any SIMATIC MV440 firmware version 6.0 or higher.

Optical identification

Stationary code reading systems

Introduction

Overview



The stationary optical code readers read various two-dimensional (2D) codes as well as one-dimensional (1D) barcodes. SIMATIC MV440 also features additional functions for measuring the marking quality (verification) for process control purposes, and for text recognition (optical character recognition, OCR) and object detection. All devices can be easily and flexibly integrated into the automation system thanks to standardized, industry-compatible interfaces and function blocks.

SIMATIC MV420

The SIMATIC MV420 series is particularly suitable for close-up to mid-range reading distances (approx. 10 mm to 400 mm).

The SIMATIC MV420 is an optical reader that has been specially designed for detecting and evaluating a variety of machine readable codes in the packaging industry (e.g. F&B, pharmaceuticals and tobacco) and industrial production (e.g. automotive, electronics and solar). The list of readable codes includes all standard matrix codes and barcodes which can be reliably detected - mostly independent of the printing technology applied and carrier medium used. One key feature of the unit is its ability to read data matrix codes (DMC). The SIMATIC MV420 device family is flexible, reliable and easy to use.

Besides this, two different lenses are available for the SIMATIC MV420 which can be adjusted to the required reading distances. In addition, various powerful integrated illumination systems are available. The models can be ordered as preconfigured or freely combinable. The particularly compact enclosures have the high degree of protection IP67.

SIMATIC MV440



The SIMATIC MV440 is an optical reader designed specifically for the recognition and evaluation of numerous machine-readable codes in industrial production. The SIMATIC MV440 device family is characterized by very high reading reliability, high-speed reading and flexible process interfacing. The product is also robust, has a high degree of protection, and is easy to use. The professional decoding software is suitable for almost all types of marking, especially sophisticated "direct part marking", on a wide range of different carrier materials.

With the "Veri-Genius" verification license, the optical MV440 readers are able to verify the marking quality of codes in accordance with the applicable standards. The device determines the quality of the applied code and helps you ensure the readability using the following process steps. Verification can be performed simultaneously with the other functions, e.g. reading of 1D and 2D codes.

With the "Text-Genius / Text-Genius Plus" text recognition licenses, the optical MV440 readers can be used for text recognition (OCR optical character recognition). Text recognition can be performed simultaneously with the other functions, e.g. reading of 1D and 2D codes.

With the "Pat-Genius" object recognition license, object recognition, position detection, presence checks, completeness checks and text recognition (contour-based) are all possible. Object recognition can also be combined with the other functions.

Major differences

Optical readers	SIMATIC MV420	SIMATIC MV440
		
Housing	Extremely compact design, IP67	Compact design, IP67
Sensor / resolution	CMOS 640 x 480 pixels 752 x 480 pixels	CCD 640 x 480 pixels 1 024 x 768 pixels 1 600 x 1 200 pixels
Lens system	Freely selectable lenses (M12) Lens selection: http://www.siemens.com/tia-selection-tool	Freely selectable lenses due to C-Mount lens connection Lens selection http://www.siemens.com/tia-selection-tool
Lighting	Integrated lighting	Integrated or external lighting
Commissioning and operation	<ul style="list-style-type: none"> • Integrated web server • Auto-optimizing of parameters • Languages: English / German / French / Italian / Spanish / Chinese 	<ul style="list-style-type: none"> • Integrated web server • Auto-optimizing of parameters • Languages: English / German / French / Italian / Spanish / Chinese
Communication	<ul style="list-style-type: none"> • PROFIBUS (via communication module; M16) • PROFINET (on-board M12 or via communication module, various interfaces) • Ethernet (onboard, M12) • RS232 (onboard, M16) 	<ul style="list-style-type: none"> • PROFIBUS (via communication module, M12) • PROFINET (on-board M12 or via communication module, various interfaces) • Ethernet (onboard, M12) • RS232 (onboard, M16)
Digital inputs/outputs	<ul style="list-style-type: none"> • 1 trigger • 1 strobe • 2 programmable inputs/outputs 	<ul style="list-style-type: none"> • 1 trigger • 1 strobe • 4 programmable inputs/outputs
Optical character recognition	–	<ul style="list-style-type: none"> • Polyfont (can be used without training) • Freely trainable fonts
Object detection	–	<ul style="list-style-type: none"> • Objects/shapes are freely trainable
Verification	–	<ul style="list-style-type: none"> • ISO/IEC 29159:2011 (previously: AIM DPM-1-2006) • ISO/IEC 16022:2000 • ISO/IEC 15415:2004 • AS9132 Rev A, 2005 • ISO/IEC 15416:2000 • ANSI X3.182-1990

Application

- Automotive industry
 - Needle punched markings on various automotive power train components (cylinder heads, cylinder blocks, manifolds, etc.)
 - Laser markings on various automotive power train components (camshafts, crankshafts, pistons, connecting rods, transmission components, etc.)
 - Laser markings on electronic components, printed circuit boards, or enclosures
- Packaging (e.g. pharmaceutical, F&B and tobacco industries)
 - Printed or laser markings on folded boxes, plastic containers, etc.
 - Reading through transparent foil packaging
- Aerospace industry
 - Needle punched markings on gas turbine blades
 - Needle punched markings on various aluminum components of propulsion units
- Medical equipment
 - Laser markings on pacemakers and other implantable devices
 - Laser markings on various medical devices and drugs
- Electronics
 - Laser markings on ESD sensitive hard drive components or even on printed labels
- Semiconductor
 - Laser markings on rigid and flexible circuit boards
 - Laser markings on packaged semiconductor devices, heat sinks or heat dissipators

Optical identification

Stationary code reading systems

Introduction

Integration

The SIMATIC MV420/440 readers have industry-standard PROFINET and communication module interfaces on the device. In addition, communications interfaces such as Ethernet and RS232 are directly available on the device.

Via the specified interfaces, the following communication services can be used:

Usable communication services	Interface
PROFINET IO (FB 79)	Onboard MV400 PROFINET interface.
PROFINET IO (FB 101, Ident profile)	Onboard MV400 PROFINET interface.
PROFINET IO (FB 45, FB 101, Ident profile)	Via communication module interface, with communication module RF180C.
Ethernet/IP	Via communication module interface, with communication module RFID 181EIP.
PROFIBUS DP V0/1 (FB 45, Ident profile)	Via communication module interface, with communication module ASM 456.
TCP/IP (HTTP, ASCII)	Onboard MV400 PROFINET interface.
RS232 (ASCII)	Onboard MV400 RS232 interface.
SIMATIC S7-1200, S7-300, ET 200pro	Via communication module interface, with communication module RF120C, RF170C, ASM 475.

The preferred connection of the SIMATIC MV420/440 readers in the SIMATIC environment is the onboard PROFINET interface. The standard function block "Ident Profile" (FB 101) is available for this interface. This type of connection is a component of the device library of SIMATIC TIA Portal, Version 13 SP1 or higher, and is compatible for the connection of communication modules.

Furthermore, the SIMATIC MV420/440 readers are compatible with the predecessor products SIMATIC VS130-2. For this purpose, the onboard PROFINET interface is released for use with function block FB 79.

A separate function block called "LDrivers MV4X0" is available for the connection to SIMOTION systems. You will find additional information on the topic of LDrivers MV4x0 under: <http://support.automation.siemens.com/WW/view/en/67385474>

4

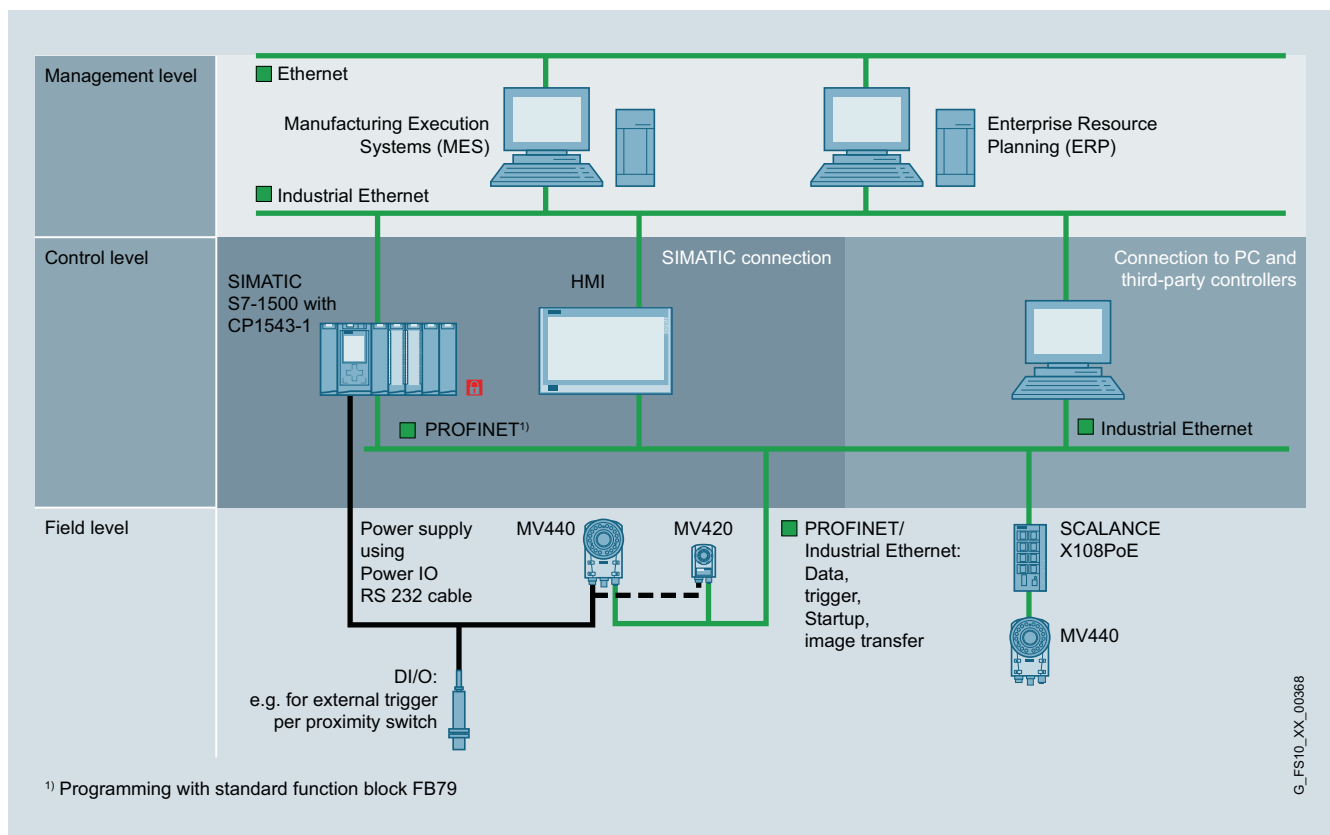

Integration of SIMATIC MV420/MV440 with a direct connection to PROFINET or Ethernet, with/without PoE (PLC and HMI via Profinet/Ethernet; trigger via DI)

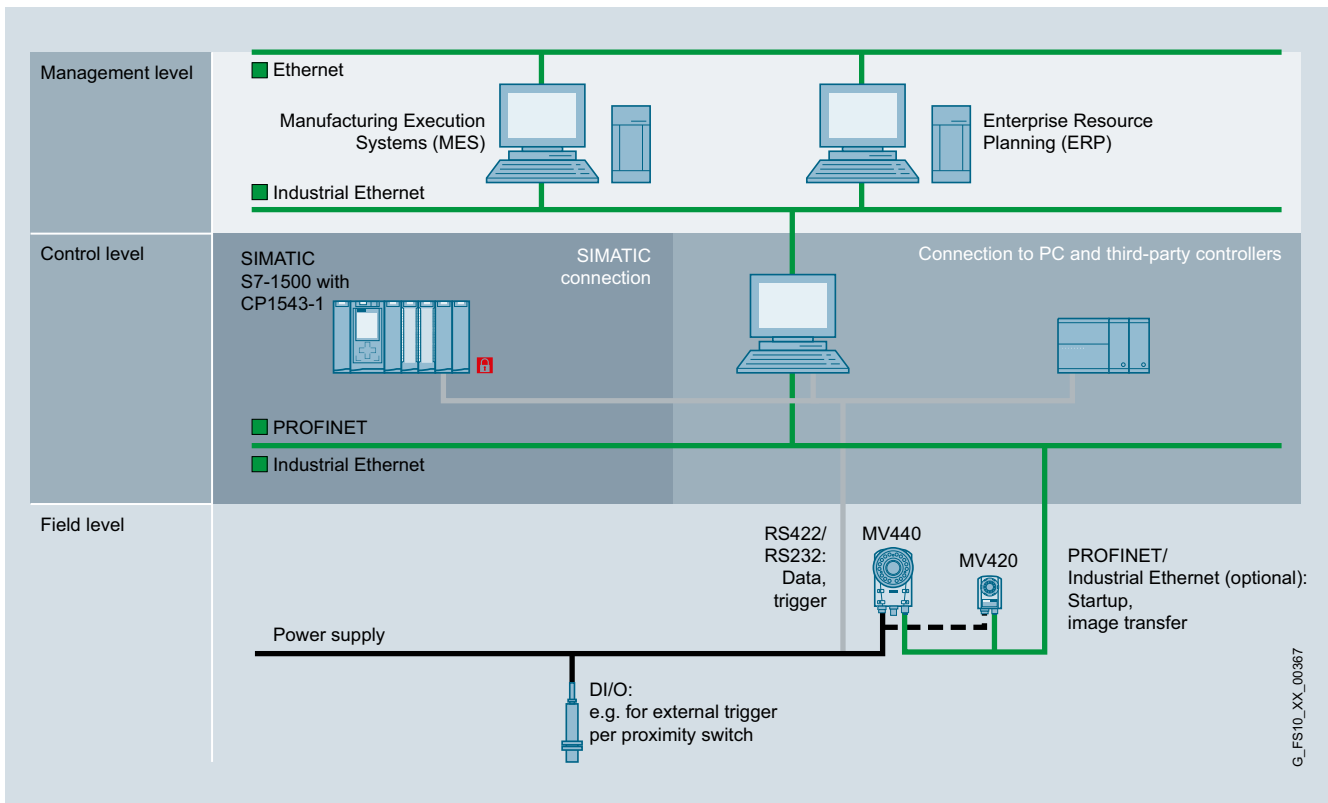

Integration of SIMATIC MV420/MV440 with connection via RS232 (PLC via RS232; trigger via DI; HMI via Ethernet)

Via the onboard communication module interface, all communication modules can be used, e.g. for the PROFIBUS connection. The communication module interface is compatible with all available communication modules both electrically and with regard to protocol. The connection via a communication module therefore makes it possible to switch between optical code readers and RFID readers, simply by reconnection. The PLC programming is performed with the aid of function blocks that are available for SIMATIC and SIMOTION.

A frequently applied integration method is the connection of the SIMATIC MV420/440 readers to the controller (e.g. transmission of the read results) via communication modules. The onboard PROFINET interface is thus available for a separate connection to HMI or a control center.

The advantage of connecting SIMATIC MV420/440 to a communication module is that a wide variety of PLC types and fieldbus systems can be connected. Furthermore, with the communication modules, the complete range of cables of these modules is available. For details on this, see chapter 5 "Communication modules".

Optical identification

Stationary code reading systems

Introduction

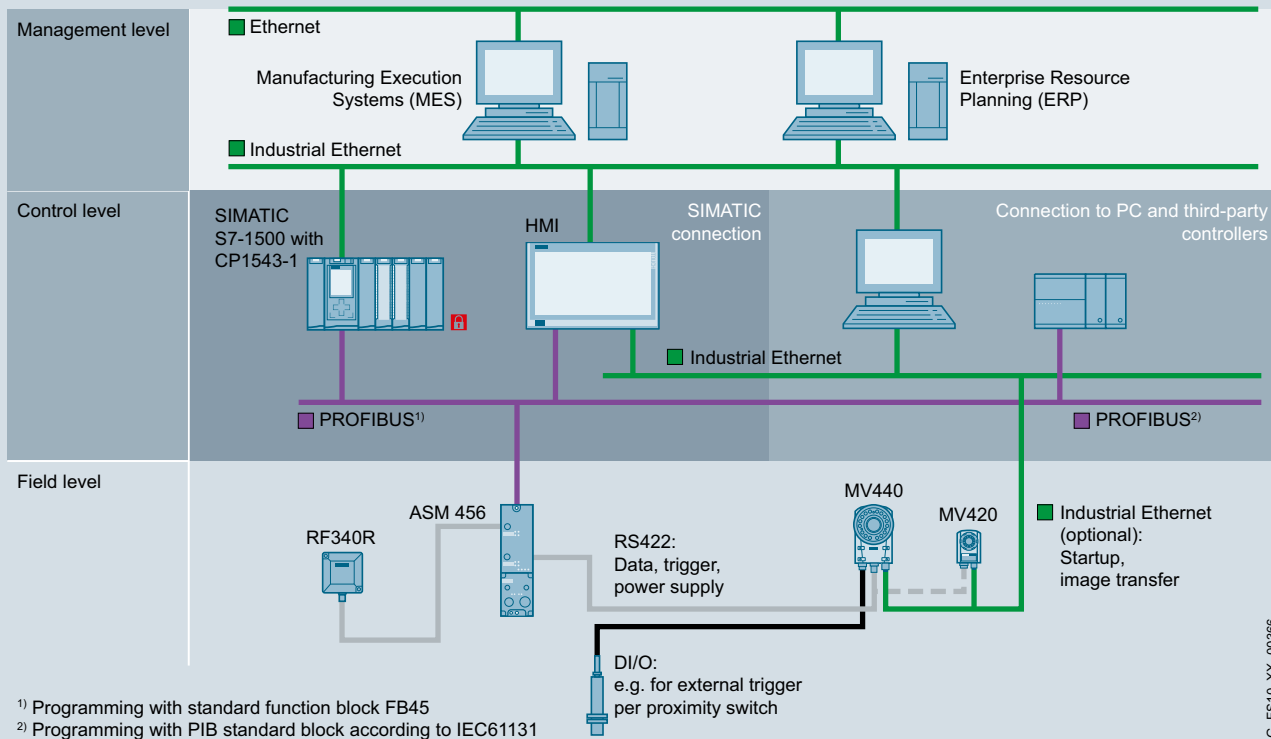

Integration of SIMATIC MV420/MV440 by means of the ASM 456 communication module (PLC via Profibus; HMI via Ethernet)

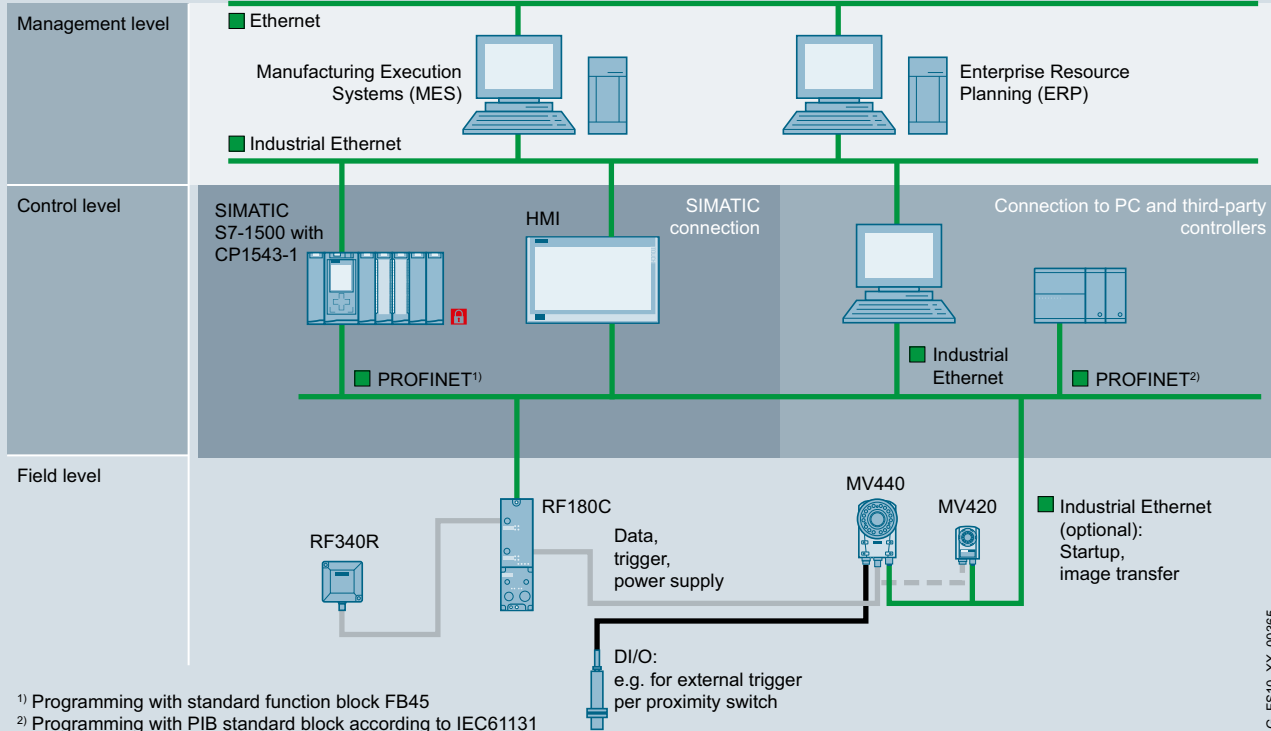

Integration of SIMATIC MV420/MV440 by means of the SIMATIC RF180C communication module (PLC via Profinet; HMI via Ethernet; trigger via DI or RS422)

Overview

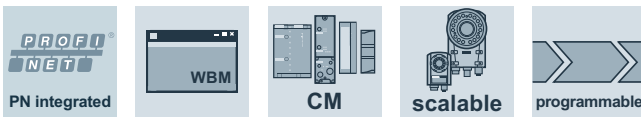

The SIMATIC MV420 is a particularly compact optical reader and is suitable for close-up to mid-range reading distances (approx. 10 mm to 400 mm).

The optical SIMATIC MV420 reader has been specifically designed for detecting and evaluating a variety of machine readable codes in the packaging industry (e.g. F&B, pharmaceuticals, and tobacco) and industrial production (e.g. automotive, electronics, and solar). The list of readable codes includes all standard matrix codes and barcodes which can be reliably detected - mostly independent of the printing technology applied and carrier medium used. One key feature of the unit is its ability to read data matrix codes (DMC). The SIMATIC MV420 device family is flexible, reliable and easy to use.

Highlights at a glance:

- Compact design with IP67 degree of protection.
- Variety of lenses with variable reading distances.
- Integrated high-performance lighting.
- Web server technology: a normal Web browser is sufficient for parameter assignment.
- Interfaces: Ethernet, PROFINET, RS232, DI/DO, and direct connection to RFID communication modules (ASM).
- Exceptionally high reading speeds, depending on the model.

Further important product characteristics are:

- Excellent read algorithms based on many years of experience in the development and production of optical readers for industrial applications.
- No special knowledge required for reliable parameterization of reading features. Parameterization usually unnecessary, and is only required for difficult to read codes. "Setup" is performed automatically by presenting a readable code pattern.
- Code quality evaluation: Displays the key quality parameters of the code to be read.
- Customized user interface can be easily generated with SIMATIC WinCC flexible/WinCC.

- Web-based user interface; can run on a variety of platforms meeting the following requirements: Internet browser (IE 6.0 or higher), JAVA-VM (MS, SUN).
- Password protected user interface with integrated access rights administration.
- Web-based user interface available for easy integration with an HMI device. The browser and JAVA VM requirements previously mentioned also apply in this case.
- 6 language versions (operator interface, manual and online help are each available in German, English, French, Spanish, Italian, and Chinese).

In addition, SIMATIC MV420 SR-P offers the following highlights:

- Autotrigger mode: Automatic detection of a code without an external trigger signal.
 - Savings in sensor technology and cabling.
 - Reduced potential for error as there are fewer components.
 - Solution for applications where proximity switches and light barriers cannot be used
- Open Web API interface for comfortable creation of customized applications and PC-based camera remote control
- Multicode: reads multiple codes in one step within the same field of view.
 - ID-Genius: A high-performance code reading algorithm for poorly legible directly marked data matrix codes (DPM: direct part marking).

Application

Key features of the SIMATIC MV420:

- Reading of 1D and 2D codes
- Comparing the read result with a preset value
- Formatting of read results for further use.

The range of application for the SIMATIC MV420 product family extends to practically all areas of industrial production. The possibilities for use range from identification of stationary parts to fast moving parts on conveyor systems. The powerful integrated lighting allows a very compact design. Due to its high degree of protection (IP67), the device is protected against environmental influences. The optical SIMATIC MV420 reader is therefore suitable for all industrial applications, including direct part marking (DPM). In addition to industrial production, the compact design and flexibility of the optical SIMATIC MV420 reader also make it optimally suitable for the packaging industry (such as for the food and beverage, pharmaceutical and tobacco industries).

The optical readers of the MV420 series include all common communications interfaces, such as Ethernet or PROFINET, and can therefore be connected to a wide variety of systems. An integrated RS422 interface makes it possible to use all of the RFID communication modules, such those required for the PROFIBUS connection. The combination of optical reader and RFID reader is also possible on one communication module.

The reading devices are particularly easy to use and commission despite the wide variety of options for use. Parameters are automatically configured for most applications. If recalibration is required, however, parameter assignment can be carried out conveniently using an Internet browser on the integrated Web server without the need for pre-installed software.

Optical identification

Stationary code reading systems

SIMATIC MV420

Due to the properties and functions described, the emphasis for MV420 is on the following sectors and applications:

- Automotive industry:
 - Needle markings on various drive components (DPM), e.g. cylinder heads, cylinder blocks, manifolds.
 - Laser markings on various power train components (DPM), e.g. camshafts, crankshafts, cylinder piston, connecting rods, gearbox components.
 - Laser markings on electronic components, printed circuit boards, or enclosures.
- Pharmaceutical industry, food industry (F&B), tobacco industry:
 - Printed or laser markings on drugs (DPM, OCR/OCV).
 - Recording the contents of cartons (up to 150 codes).
 - Read portal by linking several cameras.
- Aerospace industry:
 - Needle or laser markings on gas turbine blades (DPM).
 - Needle or laser markings on jet engine components (DPM).
- Medical equipment:
 - Laser markings on heart pacemakers and other implants (DPM).
 - Laser markings on medical devices (DPM).
- Electronics:
 - Needle or laser markings on hard disk components.
 - Laser or etched markings on hard disk components (DPM)
- Semiconductors:
 - Laser markings on rigid and flexible circuit boards (DPM).
 - Laser markings on enclosed semiconductor components, heat sinks or heat exchangers (DPM).

More information is available in the accompanying manual.

Design

SIMATIC MV420 is a particularly compact code reader. The device can be assembled from individual components or ordered as a prefabricated unit. The MV420 is available in two versions:

- Basic model: SIMATIC MV420 SR-B
- Performance model: SIMATIC MV420 SR-P

For the individually configurable models the following individual components are available in addition to the basic units (body):

- Lenses
- Ring lights

The basic units include the protective barrel for the lens.

The preconfigured models include an integrated lens (6 mm, aperture 5.6) and a red ring light including protective barrel.

The following accessories are available for the connection and installation:

- Flexible mounting angle
- Power DIO RS232 cable (M16 connector on open end)
- M12 Ethernet cable (varying lengths)
- Ethernet cable (M12 to RJ45) for commissioning/lab operation (various lengths)
- Special communication module cable for M16 connector (M16 to M12) for connecting to RFID communication modules (ASM). Can be expanded using standard communication module cables, if required.
- Plug-in power supply for demonstration and lab operation (for office environment only)
- CD with installation/operating instructions (supplied with unit)

Further information can be found in the supplied manual.

Function

Key functions of the SIMATIC MV420:

- Reading of 1D and 2D codes (see "Overview" and "Area of application")
- Formatting of read results for further use and/or comparison
- Comparing the read result with a preset value
 - Default setting of the comparison string via one of the serial interfaces (PROFINET (ASM and onboard), PROFIBUS (communication module), RS232).
 - Comparison of the formatted read results with the comparison string
- Individual specification possible with FB 45 per read operation

The functions can be used individually or they can be combined.

The SIMATIC MV420 reads the following codes:

- 1D codes (barcodes):
 - Int. 2/5 (no checksum)
 - Int. 2/5+CS (checksum included)
 - Code 128
 - Code 39 (no checksum)
 - Code 39+CS (checksum included)
 - EAN 13
 - EAN 8
 - UPC-A
 - UPC-E
 - GS1 Databar 14
 - GS1 Databar Stacked
 - GS1 Databar Limited
 - GS1 Databar Expanded
- 2D codes:
 - DMC
 - PDF417
 - QR
 - DotCode
 - Vericode

The SIMATIC MV420 reads codes on many different components and surfaces, e.g.:

- Paper or plastic labels
- Plastic parts
- Circuit boards
- Metallic objects

The optical SIMATIC MV420 reader reads codes applied in many different ways, e.g.:

- Printed
- Dot peened
- Laser
- Stamped
- Bored

Optical identification

Stationary code reading systems

SIMATIC MV420

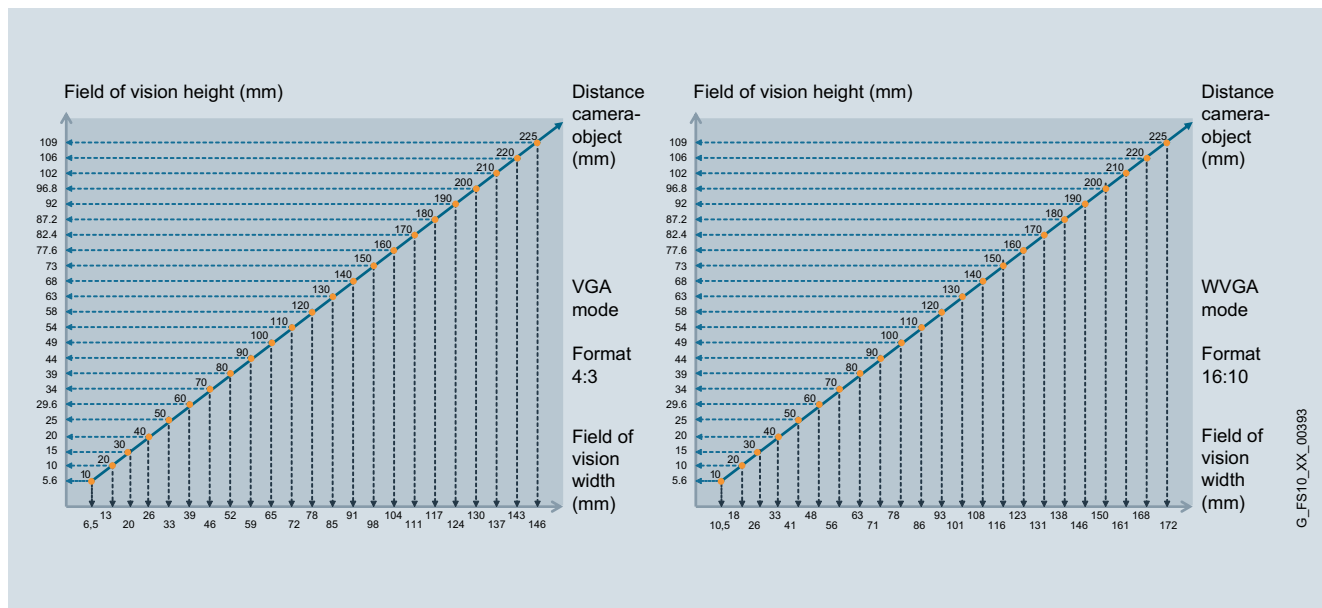

SIMATIC MV420 field of view dimensions for the 6 mm lens

4

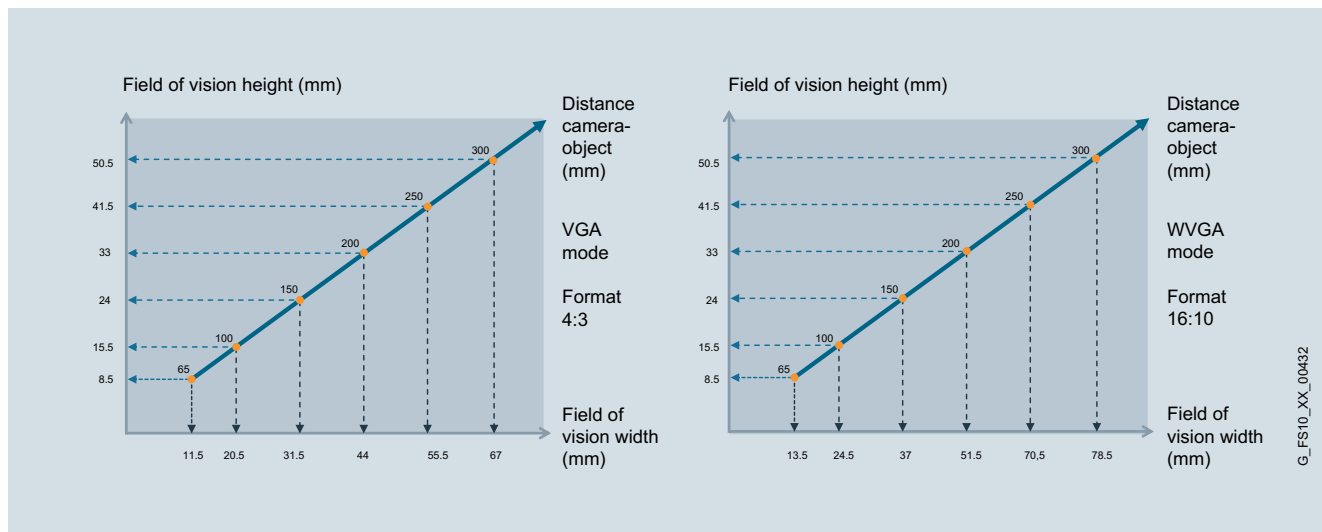

SIMATIC MV420 field of view dimensions for the 16 mm lens

Further information can be found in the supplied manual.

Integration

Various onboard connection options and convenient function blocks are available for the integration into the automation level.

In the case of SIMATIC MV420, direct connection via PROFINET, Ethernet or RS232 is possible.

In addition, communication modules are available for connection to other bus systems or the shared interface with RFID readers.

For further details on the communication modules, see chapter 5 "Communication modules".

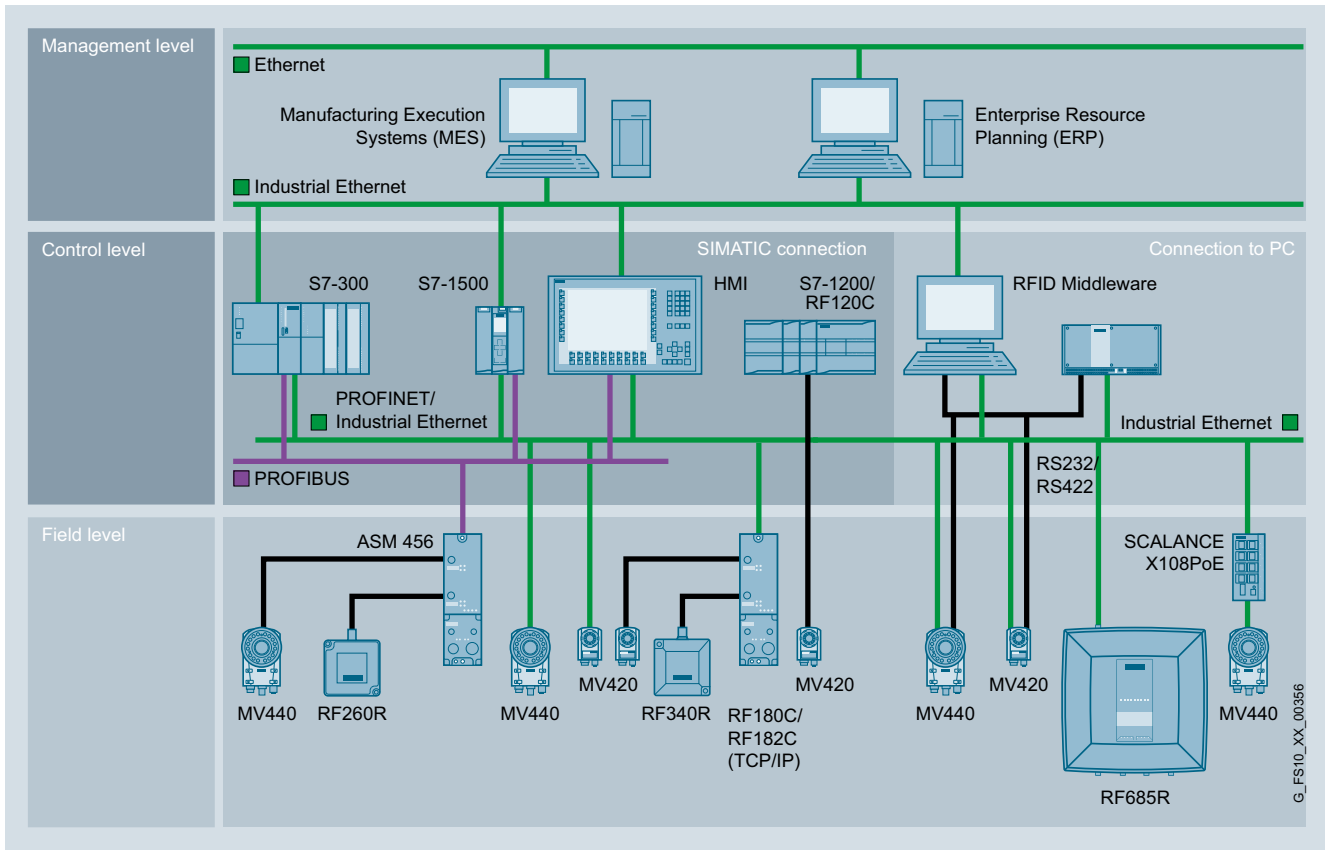

Integration of the SIMATIC MV420 in the automation environment

Technical specifications

	6GF3420-0AA20	6GF3420-0AA40	6GF3420-0AX20	6GF3420-0AX40
Article number	6GF3420-0AA20	6GF3420-0AA40	6GF3420-0AX20	6GF3420-0AX40
Product type designation	MV420 SR-B code reader	MV420 SR-P code reader	MV420 SR-B code reader (body)	MV420 SR-P code reader (body)
Suitability for operation	1D codes: Int. 2/5, Code 128, Code 39, EAN 13, EAN 8, UPC-A, UPC-E, GS1 2D codes: DMC, PDF417 (without: Truncated, Micro and Macro), QR (without: Micro and Macro), Vericode	1D codes: Int. 2/5, Code 128, Code 39, EAN 13, EAN 8, UPC-A, UPC-E, GS1 2D codes: DMC, Dot code, PDF417 (without: Truncated, Micro and Macro), QR (without: Micro and Macro), Vericode	1D codes: Int. 2/5, Code 128, Code 39, EAN 13, EAN 8, UPC-A, UPC-E, GS1 2D codes: DMC, PDF417 (without: Truncated, Micro and Macro), QR (without: Micro and Macro), Vericode	1D codes: Int. 2/5, Code 128, Code 39, EAN 13, EAN 8, UPC-A, UPC-E, GS1 2D codes: DMC, Dot code, PDF417 (without: Truncated, Micro and Macro), QR (without: Micro and Macro), Vericode
Schnittstellen				
Type of electrical connection				
• of Industrial Ethernet interface	M12, d-coded	M12, d-coded	M12, d-coded	M12, d-coded
• of the RS422 interface	M16, 12-pin, male	M16, 12-pin, male	M16, 12-pin, male	M16, 12-pin, male
• of the RS232 interface	M16, 12-pin, male	M16, 12-pin, male	M16, 12-pin, male	M16, 12-pin, male
• for supply voltage	M16, 12-pin, male	M16, 12-pin, male	M16, 12-pin, male	M16, 12-pin, male
• at the digital inputs/outputs	M16, 12-pin, male	M16, 12-pin, male	M16, 12-pin, male	M16, 12-pin, male
Number of digital inputs	3	3	3	3
Number of digital outputs	3	3	3	3
Design of digital inputs	One high-speed trigger input, 2 opto isolated inputs (NPN, PNP capability) optionally as output	One high-speed trigger input, 2 opto isolated inputs (NPN, PNP capability) optionally as output	One high-speed trigger input, 2 opto isolated inputs (NPN, PNP capability) optionally as output	One high-speed trigger input, 2 opto isolated inputs (NPN, PNP capability) optionally as output
Design of digital outputs	1 fast strobe output for external lighting, 2 isolated outputs optionally as input, short-circuit-proof, max. 100 mA	1 fast strobe output for external lighting, 2 isolated outputs optionally as input, short-circuit-proof, max. 100 mA	1 fast strobe output for external lighting, 2 isolated outputs optionally as input, short-circuit-proof, max. 100 mA	1 fast strobe output for external lighting, 2 isolated outputs optionally as input, short-circuit-proof, max. 100 mA



Optical identification

Stationary code reading systems

SIMATIC MV420

Article number	6GF3420-0AA20	6GF3420-0AA40	6GF3420-0AX20	6GF3420-0AX40
Product type designation	MV420 SR-B code reader	MV420 SR-P code reader	MV420 SR-B code reader (body)	MV420 SR-P code reader (body)
Optical data				
Design of image sensor of the camera	CMOS chip, VGA (640 x 480), WVGA (752 x 480)	CMOS chip, VGA (640 x 480), WVGA (752 x 480)	CMOS chip, VGA (640 x 480), WVGA (752 x 480)	CMOS chip, VGA (640 x 480), WVGA (752 x 480)
Type of image capture	Global shutter	Global shutter	Global shutter	Global shutter
Range	10 ... 400 mm	10 ... 400 mm	10 ... 400 mm	10 ... 400 mm
Range Note	Adjustable within the range	Adjustable within the range	Adjustable within the range	Adjustable within the range
Mounting type of lens	Fixed (M12)	Fixed (M12)	M12 screw-in lens from list of accessories	M12 screw-in lens from list of accessories
Type of light source	Integrated lighting or external lighting according to accessories list	Integrated lighting or external lighting according to accessories list	Integrated ring lamp according to accessories list	Integrated ring lamp according to accessories list
Image acquisition frequency maximum	50 Hz	80 Hz	50 Hz	80 Hz
Code reading rate maximum	29 1/s	50 1/s	29 1/s	50 1/s
Type of focusing	Manual adjustment on the lens cover	Manual adjustment on the lens cover	Manual adjustment on the lens cover	Manual adjustment on the lens cover
Supply voltage, current consumption, power loss				
Supply voltage				
• at DC Rated value	24 V	24 V	24 V	24 V
• at DC	19.2 ... 28.8 V	19.2 ... 28.8 V	19.2 ... 28.8 V	19.2 ... 28.8 V
Consumed current at DC at 24 V				
• typical	0.17 A	0.17 A	0.17 A	0.17 A
• maximum	2 A	2 A	2 A	2 A
Buffering time in the event of power failure minimum	0.01 s	0.01 s	0.01 s	0.01 s
Mechanical data				
Material	Die-cast aluminum	Die-cast aluminum	Die-cast aluminum	Die-cast aluminum
Color	petrol blue	petrol blue	petrol blue	petrol blue
Permitted ambient conditions				
Ambient temperature				
• during operation	0 ... 50 °C	0 ... 50 °C	0 ... 50 °C	0 ... 50 °C
• during storage	-30 ... +70 °C	-30 ... +70 °C	-30 ... +70 °C	-30 ... +70 °C
• during transport	-30 ... +70 °C	-30 ... +70 °C	-30 ... +70 °C	-30 ... +70 °C
Relative humidity at 25 °C without condensation during operation maximum	95 %	95 %	95 %	95 %
Protection class IP	IP67	IP67	IP67	IP67
Shock resistance	According to IEC 60068-2	According to IEC 60068-2	According to IEC 60068-2	According to IEC 60068-2
Shock acceleration	150 m/s ²	150 m/s ²	150 m/s ²	150 m/s ²
Vibrational acceleration	10 m/s ²	10 m/s ²	10 m/s ²	10 m/s ²
Design, dimensions and weight				
Width	52.5 mm	52.5 mm	52.5 mm	52.5 mm
Height	70.7 mm	70.7 mm	70.7 mm	70.7 mm
Depth	39.5 mm	39.5 mm	39.5 mm	39.5 mm
Net weight	0.25 kg	0.25 kg	0.25 kg	0.25 kg
Mounting type	2 x M4 screws	2 x M4 screws	2 x M4 screws	2 x M4 screws
Product properties, functions, components general				
Product feature silicon-free	Yes	Yes	Yes	Yes
Display version	4 LEDs	4 LEDs	4 LEDs	4 LEDs
Standards, specifications, approvals				
Certificate of suitability	CE, KCC, F&B suitable, UL	CE, KCC, F&B suitable, UL	CE, KCC, F&B suitable, UL	CE, KCC, F&B suitable, UL
MTBF at 40 °C	95 y	95 y	95 y	95 y
MTBF	95 y	95 y	95 y	95 y
Accessories				
Accessories	Mounting brackets, built-in ring lamps, M12 lenses	Mounting brackets, built-in ring lamps, M12 lenses	Mounting brackets, built-in ring lamps, M12 lenses	Mounting brackets, built-in ring lamps, M12 lenses







Selection and ordering data

	Article No.		Article No.
SIMATIC MV420 SR-B Pre-configured basic model: Including lens (6 mm, aperture 5.6) and a red ring light, without multicode and ID-Genius algorithm	6GF3420-0AA20		
SIMATIC MV420 SR-P Preconfigured performance model Including lens (6 mm, aperture 5.6) and a red ring light, for very fast read rates, with multicode and ID-Genius algorithm	6GF3420-0AA40		
SIMATIC MV420 SR-B body Basic model body: Does not include multicode or the ID-Genius algorithm	6GF3420-0AX20		
SIMATIC MV420 SR-P body Performance model body: For very high read rates; includes multicode reading and the ID-Genius algorithm	6GF3420-0AX40		
Lens accessories			
Lens kit 6 mm Lens 6 mm, aperture 5.6, including protective barrel	6GF3420-0AC00-0LK0		
			
Lens kit 16 mm Lens 16 mm, aperture 4, including protective barrel	6GF3420-0AC00-1LK0		
			
Protective barrels for lenses			
Protective barrel replacement set Contains: 2x protective barrel, 3x O-rings, 8x mounting screws, offset screwdriver	6GF3420-0AC00-2AA0		
Built-in ring lights			
			
Built-in ring lamp, red	6GF3420-0AC00-1LT0		
Built-in ring lamp, white	6GF3420-0AC00-2LT0		
Built-in ring lamp, infrared	6GF3420-0AC00-3LT0		
		Cable	
		IE connecting cable M12-180/IE FC RJ45 plug-145 for commissioning, service and installation Prefabricated IE FC TP Trailing cable GP 2 x 2 (PROFINET type C) with M12 plug (D-coded) and IE FC RJ45 plug, IP65/IP67 degree of protection.	
			
		2 m	6XV1871-5TH20
		3 m	6XV1871-5TH30
		5 m	6XV1871-5TH50
		10 m	6XV1871-5TN10
		15 m	6XV1871-5TN15
		IE Connecting Cable M12-180/M12-180 Pre-assembled IE FC TP Trailing Cable GP 2 x 2 (PROFINET Type C) with two 4-pin M12 plugs (D-coded) up to 85 m, IP65/IP67 degree of protection.	
			
		0.3 m	6XV1870-8AE30
		0.5 m	6XV1870-8AE50
		1 m	6XV1870-8AH10
		1.5 m	6XV1870-8AH15
		2 m	6XV1870-8AH20
		3 m	6XV1870-8AH30
		5 m	6XV1870-8AH50
		10 m	6XV1870-8AN10
		15 m	6XV1870-8AN15
		Industrial Ethernet FastConnect plug connector, 2x2, 180° cable outlet RJ45 plug connector (10/100 Mbit/s) with rugged metal enclosure and FastConnect technology, for Industrial Ethernet FastConnect cable 2x2.	6GK1901-1BB10-2AA0
			
		For further cables, see Catalog IK PI under "Passive network components".	

Optical identification

Stationary code reading systems

SIMATIC MV420

	Article No.		Article No.
Cable 24 V power supply Power cable, M16 pre-assembled, push-pull. 		Additional accessories Industrial Ethernet Switch SCALANCE XB205-3 With five 10/100 Mbps RJ45 ports and three fiber-optic cable ports (MM FO SC). Description see page 5/28. 	
1.5 m	6GF3400-0BH15		6GK5205-3BD00-2AB2
2 m	6GF3400-1BH20		
Power supply cable DIO-RS232 Power IO RS232 cable, M16 assembled on one end, open on other end. 		Plug-in power supply (EU, US) For demo and laboratory mode (office environments only). 	
10 m	6GF3440-8BA2		6GF3420-0AC00-1PS0
30 m	6GF3440-8BA4		
Adapter cable for RFID communication modules (ASM) M16 connector (MV420) to M12 connector (communication module); length: 2 m; expandable to any length with standard communication module cables. 	6GF3420-0AC00-2CB0		
Cable for communication module interface Standard communication module cable for installation, pre-assembled connecting cable for ASM 456, RF160C, RF170C, RF180C, and RF182C. 			
2 m	6GT2891-4FH20		
5 m	6GT2891-4FH50		
10 m	6GT2891-4FN10		
20 m	6GT2891-4FN20		
50 m	6GT2891-4FN50		
All cables with M12 connectors mentioned in the chapter 5 can be used on the reader to extend the adapter cable.			
Brackets Mounting bracket for SIMATIC MV420 	6GF3420-0AC00-1AA0		

Dimensional drawings

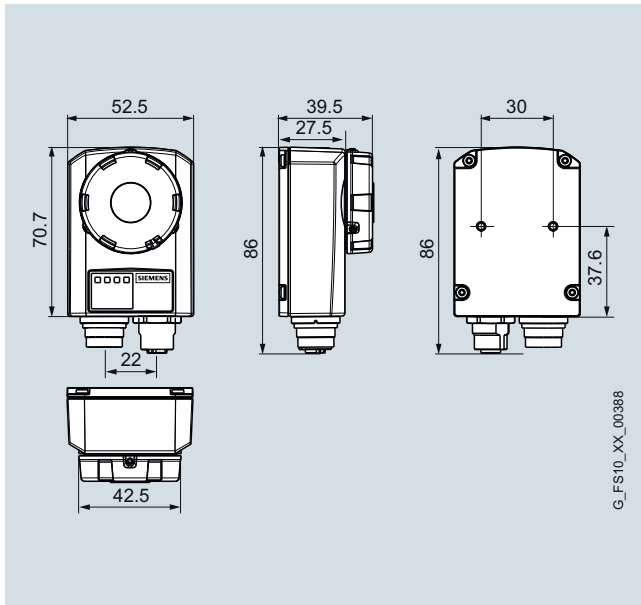

SIMATIC MV420 stationary optical reader

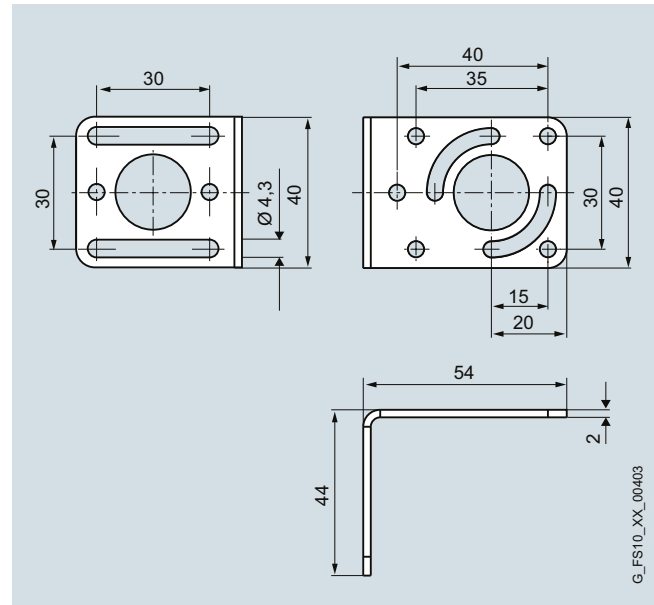

Mounting bracket for SIMATIC MV420 stationary optical reader

Optical identification

Stationary code reading systems

SIMATIC MV440

Overview



SIMATIC MV440 with built-in ring light and D65 protective barrel in plastic (included in the scope of supply)



SIMATIC MV440 with built-in ring light and D65 protective barrel (protective barrel available as accessory)



SIMATIC MV440 with external ring light and D65 protective barrel

The SIMATIC MV440 readers have been specially developed for use in industrial production. The devices offer professional decoding algorithms for machine-readable codes and text recognition in one device for production and logistics. The SIMATIC MV440 device family is characterized by flexibility, reliability and ease of use.

The list of readable codes includes all common matrix and barcodes which, regardless of the printing technology and the carrier medium used, are recognized reliably. A special feature of this device is its ability to read data matrix code (DMC) which is frequently used, especially in production, for direct part marking (DPM) and places the highest demands on the readers.

The operating range of the devices extends from 70 mm close range to 3 000 mm long range. Due to the freely selectable lenses and lighting, the working range as well as implementation in applications with special requirements is almost unrestricted. Integration in industrial automation environments is via standardized fieldbus technology. Open interfaces are also supported.

4



PN integrated

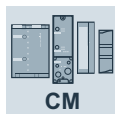

CM



scalable



programmable

Benefits



Highlights at a glance:

- Compact design with IP67 degree of protection.
- Very high reading reliability and read rates thanks to Siemens decoding algorithms
- Different screen resolutions can be selected specific to the application.
- Flexible adaptation to the application by means of freely selectable lenses and lighting.
- Option of integrated or external high-performance lighting
- Variety of interfaces: Ethernet (PoE), PROFINET (PoE), RS232, DI/DO, communication module interface.
- Many connector technologies, can be used via the communication module.
- Function block for PROFINET/PROFIBUS can be used with SIMATIC and SIMOTION.
- Web-based user interface can be used for parameter assignment and monitoring, without the need for installation.

Further important product characteristics are:

- No special knowledge required for reliable parameterization of reading features. Automatic "setup" by presenting a readable code pattern.
- Autotrigger mode: Automatic detection of a code without an external trigger signal.
 - Savings in sensor technology and cabling.
 - Reduced potential for error as there are fewer components.
 - Solution for applications in which proximity switches and light barriers cannot be used.
- Multicode function: Reads multiple codes in one step within the same field of view.
- ID-Genius: A high-performance reading algorithm for poorly legible directly marked data matrix codes (DPM: direct part marking).
- Code quality evaluation: Displays the key quality parameters of the code to be read.
- Customized user interface can be easily generated with SIMATIC WinCC flexible/WinCC.
- Open Web API interface for comfortable creation of customized applications and PC-based camera remote control
- Web-based user interface; can run on a variety of platforms meeting the following requirements: Internet browser (IE 6.0 or higher), JAVA-VM (MS, SUN).
- Extensive diagnostics functions ensure operation at the maximum read rate.
- User/password-protected operator interface with integrated management of access rights.
- 6 language versions (operator interface, compact manual and online help are each available in English, German, French, Spanish, Italian and Chinese); manual available in 2 language versions (English and German).

Application

The main functions of SIMATIC MV440 are:

- Reading 1D and 2D codes
- Optical character recognition (OCR).
- Object detection.
- Verification (measuring the code quality).
- Comparing the read result with a preset value.
- Formatting of read results for further use.

The application range of the SIMATIC MV440 product family covers all sectors and areas of industrial production and logistics. The possible applications include the identification of stationary parts through to extremely fast moving parts on a conveyor belt. The powerful integrated lighting allows a very compact design. The device has IP67 degree of protection and is therefore suitable for harsh industrial environments.

Due to its particularly powerful lighting, lenses and sensor technology, the MV440 specializes in applications for direct part marking (DPM). Due to the high picture quality, MV440 recommends itself for measuring the marking quality (verification) in the area of DPM.

Due to the properties and functions described, the emphasis for SIMATIC MV440 is on the following sectors and applications:

- Automotive industry:
 - Needle punched markings on various automotive power train components (DPM), e.g. cylinder heads, cylinder blocks, manifolds.
 - Laser markings on various automotive power train components (DPM), e.g. camshafts, crankshafts, pistons, connecting rods, transmission components.
 - Laser markings on electronic components, printed circuit boards, or enclosures.
- Pharmaceutical industry, food industry (F&B), tobacco industry:
 - Print or laser markings on medicines (DPM, OCR).
 - Recording the contents of cartons (up to 150 codes).
 - Read portal by linking several cameras.
- Aerospace industry:
 - Needle or laser markings on gas turbine blades (DPM).
 - Needle or laser markings on jet engine components (DPM).
- Medical equipment:
 - Laser markings on heart pacemakers and other implants (DPM).
 - Laser markings on medical devices (DPM).
- Electronics:
 - Needle or laser markings on hard disk components.
 - Laser or etched markings on hard disk components (DPM).
- Semiconductors:
 - Laser markings on rigid and flexible circuit boards (DPM).
 - Laser markings on enclosed semiconductor components, heat sinks or heat exchangers (DPM).

Further information can be found in the supplied manual.

Optical identification

Stationary code reading systems

SIMATIC MV440

Design

The SIMATIC MV440 is a compact, stationary optical reader. It consists of one basic unit, which can be configured with other individual components (lens, ring light, filter and protective barrel). This allows the MV440 to be optimally adapted to the application conditions.

The SIMATIC MV440 basic unit is available in three versions. They differ only with regard to the resolution of the CCD sensor and the associated recording speed mode and read rate. All three versions of the basic unit have identical functionality:

- SIMATIC MV440 SR
640 pixels x 480 pixels, 50 full screens/s
- SIMATIC MV440 HR
1 024 pixels x 768 pixels, 20 full screens/s
- SIMATIC MV440 UR
1 600 pixels x 1 200 pixels, 15 full screens/s



Using the following accessories, the SIMATIC MV440 basic units can be tailored to the requirements of the application and configured. For a detailed listing of the individual accessories, please refer to the section entitled "Accessories":

- Lenses
- Filter
- Protective barrel for lens
- Ring lights

The following accessories are available for the connection and installation:

- Flexible mounting plate
- Power DIO RS232 cable (M16 connector on open end)
- M12 Ethernet cable (varying lengths)
- Ethernet cable (M12 to RJ45) for commissioning/lab operation (various lengths)
- Standard cable with M12 plug for connection to communication modules (see Communication modules)
- Plug-in power supply for demonstration and lab operation (for office environment only)
- CD with installation/operating instructions (supplied with unit)

The following configurations are recommended for the close or distant ranges:

Configuration for close range	Lenses	Ring lights	Protective barrel for lens
	Mini lens 8.5 mm	The built-in ring light cannot be used (alternative: external mounting of a ring light).	D65 protective barrels for lenses can be used.
	Mini lens 6 mm	Built-in ring lights can be used.	
	Mini lens 12 mm		
	Mini lens 16 mm		
	Mini lens 25 mm		
	Mini lens 35 mm		
	Mini lens 50 mm		Use of the D65 protective barrel extension for lenses required.
Mini lens 75 mm			
Configuration for distant range	Lenses	Ring lights	Protective barrel for lens
	Mini lens 6 mm	External ring lights can be used.	D65 protective barrels for lenses can be used.
	Mini lens 8.5 mm		
	Mini lens 12 mm		
	Mini lens 16 mm		
	Mini lens 25 mm		
	Mini lens 35 mm		
	Mini lens 50 mm		
Mini lens 75 mm			

Function

The main functions of SIMATIC MV440 are:

- **Reading** 1D and 2D codes
- **Verification** (requires license "Veri-Genius")
- **Text recognition** (requires license "Text-Genius")
- **Object recognition** (requires license "Pat-Genius")
- **Comparison** of the read result with a default value
- **Formatting** the read result for forwarding

The functions can be used individually or they can be combined.

All functions, including all licenses, are available to the user in demo mode on each version of the MV440. It is therefore possible to test a licensed function at any time. However, the output result is unusable, because one or more characters of the result will be randomly replaced by the '?' character.

Binary results are completely suppressed.

Read

The SIMATIC MV440 reads the following 1D and 2D codes (detailed information can be found in the manual):

- 1D codes (barcodes):
 - Int. 2/5 (with/without checksum)
 - Code 128
 - Code 93
 - Code 39 (with/without checksum)
 - Code 32
 - EAN 13
 - EAN 8
 - UPC-A
 - UPC-E
 - CodaBar
 - GS1 DataBar (Omnidirectional, Stacked, Limited, Expanded)
 - Pharmacode (0° and 180°)
 - Postnet
- 2D codes:
 - Data Matrix Code (ECC 0 - 200)
 - PDF417 (without: Truncated, Micro and Macro)
 - QR (without: Micro and Macro)
 - DotCode
 - Vericode (demo mode/VeriCode license)

Verification

Verification is the term used for measuring the marking quality of 1D and 2D codes. This additional functionality is subject to license and is available for every SIMATIC MV440 by installing the "Veri-Genius license". The following verification methods are supported:

- ISO/IEC TR29158 (previously AIM DPM-1-2006)
- Siemens DPM
- ISO/IEC 15415
- AS9132 Rev. A (previously IAQG)
- ISO/IEC 15416 (previously ANSI X3.182-1990)

Optical identification

Stationary code reading systems

SIMATIC MV440

Optical character recognition

Text recognition is used to detect plain text (Optical Character Recognition: OCR). This additional functionality is subject to license and is available for every SIMATIC MV440 by installing the "Text-Genius license" or the "Text-Genius-Plus License".

Text recognition with the "Text-Genius license" is able to recognize many fonts without training immediately after installation. Particularly suitable fonts are:

- OCR-A
- Semifont M13
- and similar fonts

With the "Text-Genius Plus license", text recognition can be expanded to include numerous fonts, print image versions (e.g. distortions), and special characters. By contrast, this version requires training, but offers almost unlimited potential in expanding the range of characters to be recognized.

Object detection

Object recognition is used for finding and recognizing trained patterns in the picture. This functionality can be used alone or in combination with all other functions mentioned. Accordingly, it has different areas of application: Shape recognition offers the following functionality:

- Object recognition (classification)
- Position detection (position, rotational position, scaling)
- Presence check (object recognition and position check with setpoint specification)
- Completeness check (multiple presence check with setpoint specification)
- Text recognition (based on the contour of any character or symbol). However, shape recognition can also be used in combination with text recognition, for example. In this case, the text recognition read area can track the current position of an object or label.

Note: In demo mode, the full functionality of the devices is available. Testing of a licensed function is therefore possible at any time. However, the output result is unusable, because one or more characters of the result will be randomly replaced by the character '?'. Binary results are completely suppressed.

Integration

Various onboard connection options and convenient function blocks are available for the integration into the automation level.

In the case of SIMATIC MV440, for example, direct connection via PROFINET, Ethernet or RS232 is possible.

In addition, communication modules are available for connection to other bus systems or the shared interface with RFID readers.

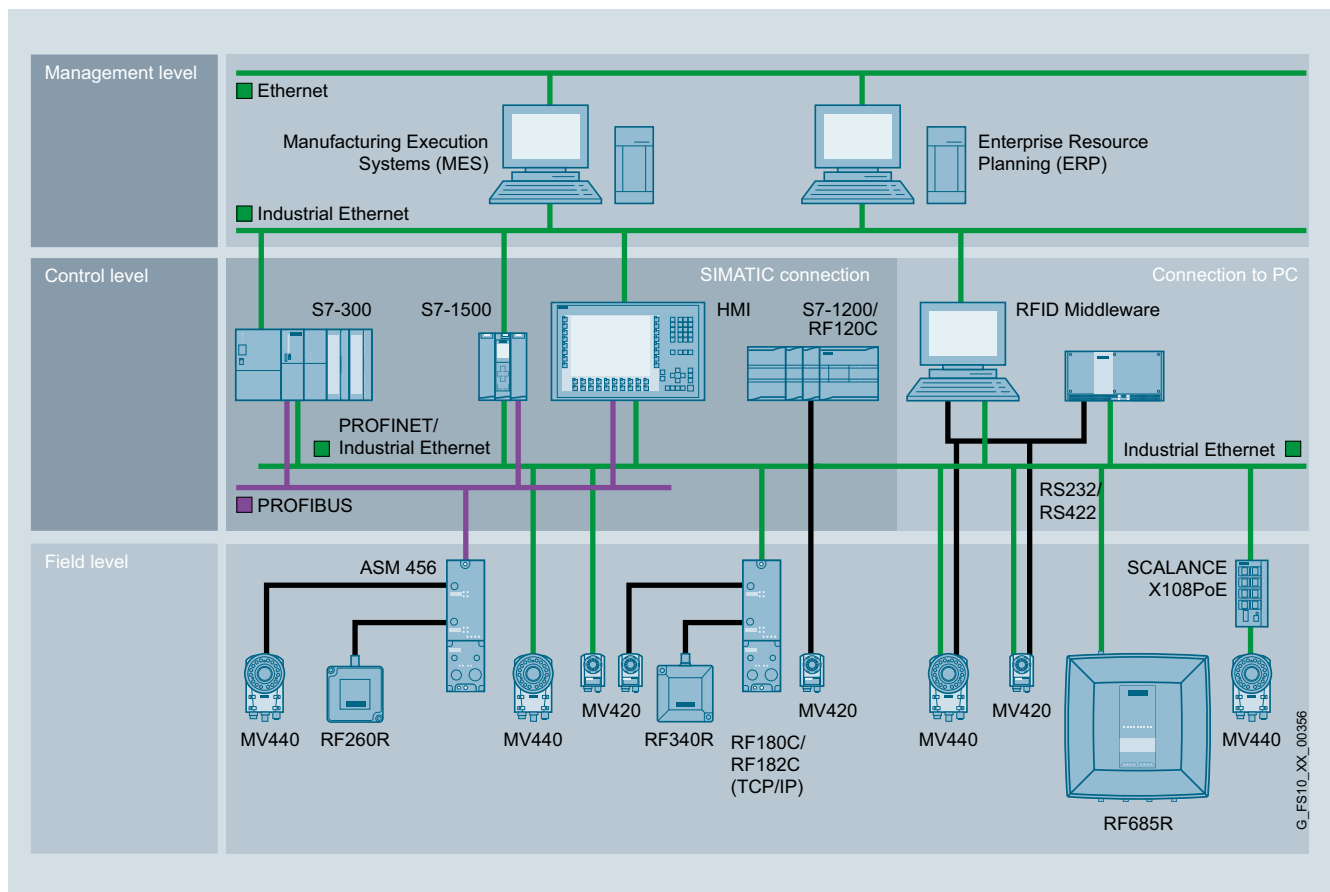

Technical specifications

Article number	6GF3440-1CD10	6GF3440-1GE10	6GF3440-1LE10
Product type designation	MV440 SR code reader	MV440 HR code reader	MV440 UR code reader
Suitability for operation	1D codes: Int. 2/5, Code 128, Code 93, Code 39, Code 32, EAN 13, EAN 8, UPC-A, UPC-E, GS1, Pharmacode, Postnet 2D codes: DMC, Dot code, PDF417 (without: Truncated, Micro and Macro), QR (without: Micro and Macro), Vericode Text recognition: OCR-A, Semifont M13, similar fonts Code verification: ISO/IEC 29158, Siemens DPM, ISO/IEC 15415, AS9132 Rev. A, ISO/IEC 16416	1D codes: Int. 2/5, Code 128, Code 93, Code 39, Code 32, EAN 13, EAN 8, UPC-A, UPC-E, GS1, Pharmacode, Postnet 2D codes: DMC, Dot code, PDF417 (without: Truncated, Micro and Macro), QR (without: Micro and Macro), Vericode Text recognition: OCR-A, Semifont M13, similar fonts Code verification: ISO/IEC 29158, Siemens DPM, ISO/IEC 15415, AS9132 Rev. A, ISO/IEC 16416	1D codes: Int. 2/5, Code 128, Code 93, Code 39, Code 32, EAN 13, EAN 8, UPC-A, UPC-E, GS1, Pharmacode, Postnet 2D codes: DMC, Dot code, PDF417 (without: Truncated, Micro and Macro), QR (without: Micro and Macro), Vericode Text recognition: OCR-A, Semifont M13, similar fonts Code verification: ISO/IEC 29158, Siemens DPM, ISO/IEC 15415, AS9132 Rev. A, ISO/IEC 16416
Schnittstellen			
Type of electrical connection			
• of Industrial Ethernet interface	M12, d-coded, PoE	M12, d-coded, PoE	M12, d-coded, PoE
• of the RS422 interface	M12, 8-pin, male	M12, 8-pin, male	M12, 8-pin, male
• of the RS232 interface	M16, 12-pin, male	M16, 12-pin, male	M16, 12-pin, male
• for supply voltage	M16, 12-pin, male	M16, 12-pin, male	M16, 12-pin, male
• at the digital inputs/outputs	M16, 12-pin, male	M16, 12-pin, male	M16, 12-pin, male
Number of digital inputs	5	5	5
Number of digital outputs	5	5	5
Design of digital inputs	1 high-speed trigger input 4 opto isolated inputs (NPN, PNP capability) optionally as output	1 high-speed trigger input 4 opto isolated inputs (NPN, PNP capability) optionally as output	1 high-speed trigger input 4 opto isolated inputs (NPN, PNP capability) optionally as output
Design of digital outputs	1 fast strobe output for external lighting 4 isolated outputs optionally as input, short-circuit-proof, max.100 mA	1 fast strobe output for external lighting 4 isolated outputs optionally as input, short-circuit-proof, max.100 mA	1 fast strobe output for external lighting 4 isolated outputs optionally as input, short-circuit-proof, max.100 mA
Optical data			
Design of image sensor of the camera	CCD chip 1/3", 640 x 480	CCD Chip 1/3", 1 024 x 768	CCD chip 1/1.8", 1 600 x 1 200
Type of image capture	Global shutter with manual or automatic exposure time	Global shutter with manual or automatic exposure time	Global shutter with manual or automatic exposure time
Range	70 ... 3 000 mm	70 ... 3 000 mm	70 ... 3 000 mm
Range Note	Using C-mount lenses and lens accessories, the range can be exactly matched to the application	Using C-mount lenses and lens accessories, the range can be exactly matched to the application	Using C-mount lenses and lens accessories, the range can be exactly matched to the application
Mounting type of lens	C mount lens connection with Plexiglas lens protection, 65 mm diameter	C mount lens connection with Plexiglas lens protection, 65 mm diameter	C mount lens connection with Plexiglas lens protection, 65 mm diameter
Type of light source	Integrated lighting or external lighting according to accessories list	Integrated lighting or external lighting according to accessories list	Integrated lighting or external lighting according to accessories list
Image acquisition frequency maximum	80 Hz	30 Hz	25 Hz
Code reading rate maximum	80 1/s	30 1/s	25 1/s
Type of focusing	Manual adjustment on the lens	Manual adjustment on the lens	Manual adjustment on the lens
Supply voltage, current consumption, power loss			
Supply voltage			
• at DC Rated value	24 V	24 V	24 V
• at DC	19.2 ... 28.8 V	19.2 ... 28.8 V	19.2 ... 28.8 V
Consumed current at DC at 24 V			
• typical	0.27 A	0.27 A	0.27 A
• maximum	2 A	2 A	2 A
Buffering time in the event of power failure minimum	0.01 s	0.01 s	0.01 s
Mechanical data			
Material	Die-cast aluminum	Die-cast aluminum	Die-cast aluminum
Color	petrol blue	petrol blue	petrol blue

Optical identification

Stationary code reading systems

SIMATIC MV440

	6GF3440-1CD10	6GF3440-1GE10	6GF3440-1LE10
Article number			
Product type designation	MV440 SR code reader	MV440 HR code reader	MV440 UR code reader
Permitted ambient conditions			
Ambient temperature			
• during operation	0 ... 50 °C	0 ... 50 °C	0 ... 50 °C
• during storage	-30 ... +70 °C	-30 ... +70 °C	-30 ... +70 °C
• during transport	-30 ... +70 °C	-30 ... +70 °C	-30 ... +70 °C
Relative humidity at 25 °C without condensation during operation maximum	95 %	95 %	95 %
Protection class IP	IP67	IP67	IP67
Shock resistance	According to IEC 60068-2	According to IEC 60068-2	According to IEC 60068-2
Shock acceleration	100 m/s ²	100 m/s ²	100 m/s ²
Vibrational acceleration	10 m/s ²	10 m/s ²	10 m/s ²
Design, dimensions and weight			
Width	68 mm	68 mm	68 mm
Height	122 mm	122 mm	122 mm
Depth	45 mm	45 mm	45 mm
Net weight	0.55 kg	0.55 kg	0.55 kg
Mounting type	4 x M4 screws	4 x M4 screws	4 x M4 screws
Product properties, functions, components general			
Product feature silicon-free	Yes	Yes	Yes
Display version	5 LEDs	5 LEDs	5 LEDs
Standards, specifications, approvals			
Certificate of suitability	CE, KCC, F&B suitable, UL	CE, KCC, F&B suitable, UL	CE, KCC, F&B suitable, UL
MTBF at 40 °C	88 y	88 y	88 y
MTBF	88 y	88 y	88 y
Accessories			
Accessories	Licenses (verification and text recognition), mounting brackets, built-in ring lights, external ring lights, C-mount lenses, protective barrels for lenses	Licenses (verification and text recognition), mounting brackets, built-in ring lights, external ring lights, C-mount lenses, protective barrels for lenses	Licenses (verification and text recognition), mounting brackets, built-in ring lights, external ring lights, C-mount lenses, protective barrels for lenses





Selection and ordering data









	Article No.		Article No.
SIMATIC MV440 SR For one- and two-dimensional codes. Optional: Text recognition (OCR), object detection and verification of barcodes and data matrix codes. Variable image field and distance. Resolution: 640 x 480 pixels. PoE; IP67 using protective barrel for lens and sealing caps, otherwise IP40; package comprises reader, CD and plastic protective barrel for lens.	6GF3440-1CD10	Accessories C-mount lenses Mini lenses with fixed focal length, adjustable aperture and focus (see "Lenses" section on page 4/32).	
SIMATIC MV440 HR For one- and two-dimensional codes. Optional: Text recognition (OCR), object detection and verification of barcodes and data matrix codes. Variable image field and distance. Resolution: 1 024 x 768 pixels. PoE; IP67 using protective barrel for lens and sealing caps, otherwise IP40; package comprises reader, CD and plastic protective barrel for lens.	6GF3440-1GE10		
SIMATIC MV440 UR For one- and two-dimensional codes. Optional: Text recognition (OCR), object detection and verification of barcodes and data matrix codes. Variable image field and distance. Resolution: 1 600 x 1 200 pixels PoE; IP67 using protective barrel for lens and sealing caps, otherwise IP40; package comprises reader, CD and plastic protective barrel for lens.	6GF3440-1LE10	Intermediate ring sets for utilizing mini lenses for close-range macro photography (see "Lenses" section on page 4/32). Filters for utilizing mini lenses (see "Lenses" section on page 4/32). Protective barrels for lenses D65 protective barrel for lens made of metal, for built-in ring lights, internal diameter 57 mm, max. lens length 57 mm, IP67 degree of protection.	
Optional software modules Text recognition module "Text-Genius" License for the module "Text-Genius", supplied on USB flash drive; executable on SIMATIC MV440 firmware V3.0 and higher (MV440 not included in the scope of supply). For a description, see page 4/50.	6GF3400-0SL01	 <ul style="list-style-type: none"> • Glass front pane • Plastic front pane 	6GF3440-8AC11 6GF3440-8AC21
Text recognition module "Text-Genius Plus" License for the module "Text-Genius Plus", supplied on USB flash drive; executable on SIMATIC MV440 firmware V5.0 and higher (MV440 not included in the scope of supply). For a description, see page 4/50.	6GF3400-1SL01	D65 protective barrel for lens made of plastic; to achieve IP67 degree of protection; suitable for all variants of MV440 and for use with built-in ring lights; max. internal diameter 55 mm, max. lens length 48 mm.	6GF3440-8AC12
Verification module "Veri-Genius" License for the module "Veri-Genius", supplied on USB flash drive; executable on SIMATIC MV440 firmware V4.0 and higher (MV440 not included in the scope of supply). For a description, see page 4/45.	6GF3400-0SL02		
Shape recognition module "Pat-Genius" License for the module "Pat-Genius", supplied on USB flash drive; executable on SIMATIC MV440 firmware V6.0 and higher (MV440 not included in the scope of supply). For a description, see page 4/54.	6GF3400-0SL03	D65 protective barrel extension for lens made of metal, for built-in ring lights, internal diameter 55 mm, extension by 35 mm (cascadable), IP67 degree of protection.	6GF3440-8AC13
			

Optical identification

Stationary code reading systems

SIMATIC MV440

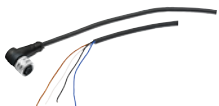
	Article No.		Article No.
Built-in ring lights		Cables	
 <ul style="list-style-type: none"> • Built-in ring light, red Light source: LED red (630 nm) Flash duration 20 µs to 10 ms, range of illumination 800 mm, mounting materials included, IP67 degree of protection when using protective barrel for lens. • Built-in ring light, white Light source: White LED (440 nm to 650 nm) Flash duration 20 µs to 10 ms, range of illumination 800 mm, mounting materials included, IP67 degree of protection when using protective barrel for lens. • Built-in ring light, green Light source: Green LED (500 nm to 570 nm) Flash duration 20 µs to 10 ms, range of illumination 800 mm, mounting materials included, IP67 degree of protection when using protective barrel for lens.. • Built-in ring lamp, infrared Light source: Infrared LED (850 nm to 880 nm) Flash duration 20 µs to 10 ms, range of illumination 800 mm, mounting materials included, IP67 degree of protection when using protective barrel for lens. 	<p>6GF3440-8DA11</p> <p>6GF3440-8DA21</p> <p>6GF3440-8DA31</p> <p>6GF3440-8DA41</p>	<p>IE connecting cable M12-180/IE FC RJ45 plug-145 for commissioning, service and installation Prefabricated IE FC TP trailing cable GP 2 x 2 (PROFINET type C) with M12 plug (D-coded) and IE FC RJ45 plug, IP65/IP67 degree of protection.</p>  <p>2 m</p> <p>3 m</p> <p>5 m</p> <p>10 m</p> <p>15 m</p>	<p>6XV1871-5TH20</p> <p>6XV1871-5TH30</p> <p>6XV1871-5TH50</p> <p>6XV1871-5TN10</p> <p>6XV1871-5TN15</p>
External ring lights		IE connecting cable M12-180/M12-180	
 <ul style="list-style-type: none"> • Ring light, metal, infrared, clear light source LED infrared, light source 850 nm, light source 500 mm to 23 000 mm, suitable for D65 lens protective barrel, supply voltage: 24 V (18 V ... 30 V), dimensions B x H x T (mm): 142 x 142 x 42.4, degree of protection IP67. • Ring light, metal, red, clear light source LED infrared, light source 500 mm to 3 000 mm, suitable for D65 lens protective barrel, supply voltage: 24 V (18 V ... 30 V) dimensions W x H x D (mm): 142 x 142 x 42.4, degree of protection IP67. 	<p>6GF3400-0LT01-7BA1</p> <p>6GF3400-0LT01-8DA1</p>	<p>Pre-assembled IE FC TP trailing cable GP 2 x 2 (PROFINET type C) with two 4-pin M12 connectors (D-coded) up to max. 85 m, IP65/IP67 degree of protection, RJ45 assembly possible with plug-in connector 6GK1 901-1BB10-2AA0 (see below).</p>  <p>0.3 m</p> <p>0.5 m</p> <p>1 m</p> <p>1.5 m</p> <p>2 m</p> <p>3 m</p> <p>5 m</p> <p>10 m</p> <p>15 m</p>	<p>6XV1870-8AE30</p> <p>6XV1870-8AE50</p> <p>6XV1870-8AH10</p> <p>6XV1870-8AH15</p> <p>6XV1870-8AH20</p> <p>6XV1870-8AH30</p> <p>6XV1870-8AH50</p> <p>6XV1870-8AN10</p> <p>6XV1870-8AN15</p>
		Industrial Ethernet FastConnect plug connector, 2x2, 180° cable outlet	
		<p>RJ45 plug connector (10/100 Mbit/s) with rugged metal enclosure and FastConnect connection method. For Industrial Ethernet FastConnect cable 2x2.</p>  <p>For further cables, see Catalog IK PI under "Passive network components".</p>	<p>6GK1901-1BB10-2AA0</p>

	Article No.		Article No.
<p>Cable for communication module interface Communication module cable for connection to communication modules, e.g. ASM 456, RF160C, RF170C, RF180C, and RF182C. Plug-in cable pre-assembled for SIMATIC MV440.</p>  <p>2 m 5 m 10 m 20 m 50 m</p> <p>All cables with M12 connectors mentioned in the chapter 5 can be used on the reader to extend the adapter cable.</p>	<p>6GT2891-4FH20 6GT2891-4FH50 6GT2891-4FN10 6GT2891-4FN20 6GT2891-4FN50</p>	<p>Mounting accessories</p> <p>Reader mounting plate Dimensions W x H x D (mm) 80 x 80 x 60, plate thickness: 4 mm</p> 	<p>6GF3440-8CA</p>
<p>Cable 24 V power supply Power cable, M16 pre-assembled, push-pull.</p>  <p>1.5 m 2 m</p>	<p>6GF3400-0BH15 6GF3400-1BH20</p>	<p>Mounting plate for external ring lights Dimensions W x H x D (mm) 96 x 76 x 46, plate thickness: 4 mm</p> 	<p>6GF3440-8CD01</p>
<p>Cable power supply DIO RS232 Power IO RS232 cable, M16 prefabricated at one end, other end open.</p>  <p>10 m 30 m</p>	<p>6GF3440-8BA2 6GF3440-8BA4</p>	<p>Support system, tri-plate Dimensions W x H x D (mm) 80 x 80 x 60, plate thickness: 4 mm</p> 	<p>6GF9002-7AD</p>
<p>Cable for external ring lights Suitable for 6GF3400-OLT01-7BA1, 6GF3400-OLT01-8DA1; M12, open end, 4-pole, not suitable for drag cables, cable connects external ring lights with the control cabinet (24 V, GND, strobe), length 10 m.</p> 	<p>6GF3440-8BC4</p>	<p>Additional accessories</p> <p>SCALANCE X108PoE Industrial Ethernet Switch With 6 x 10/100 Mbps RJ45 ports, electrical 2 x 10/100 Mbps RJ45 PoE ports, electrical. For connecting the MV440 via Power-over-Ethernet (PoE). See also page 5/29.</p> 	<p>6GK5108-0PA00-2AA3</p>
<p>Adapter cable for external ring lights Suitable for 6GF3400-OLT01-7BA1, 6GF3400-OLT01-8DA1; enables direct connection of external ring lights to the MV440 when using power supply cable DIO-RS232 (see above). M16, 12-pin socket; M16, 12-pin connector; M12, 4-pin socket, length 25 cm.</p> 	<p>6GF3440-8BD1</p>		

Optical identification

Stationary code reading systems

SIMATIC MV440

Dimensional drawings

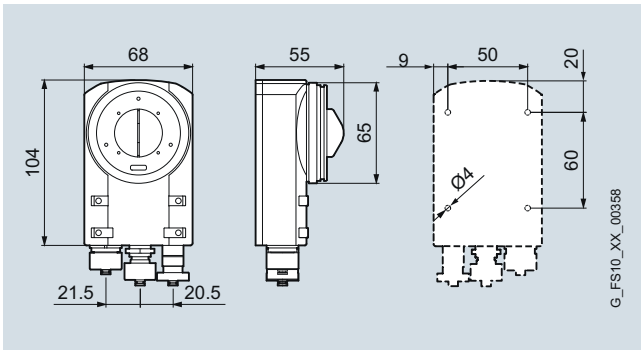

SIMATIC MV440 stationary optical reader

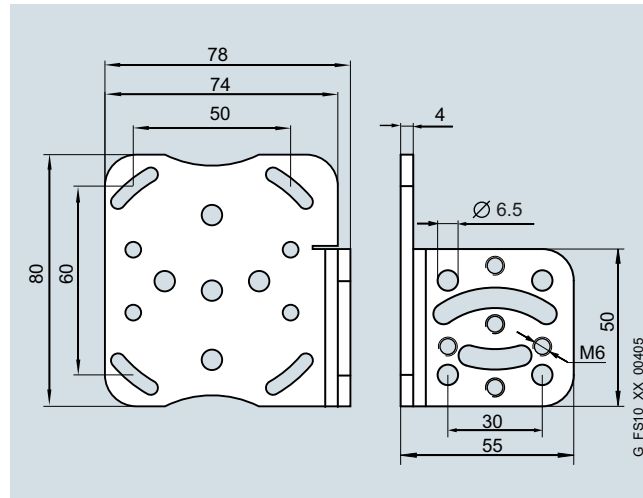

Mounting bracket for the SIMATIC MV440 optical reader

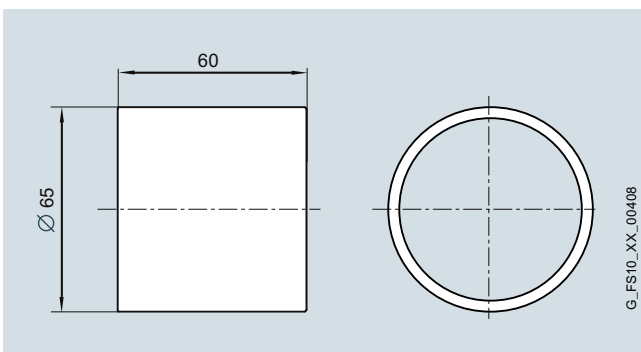

Protective barrel for lens D65

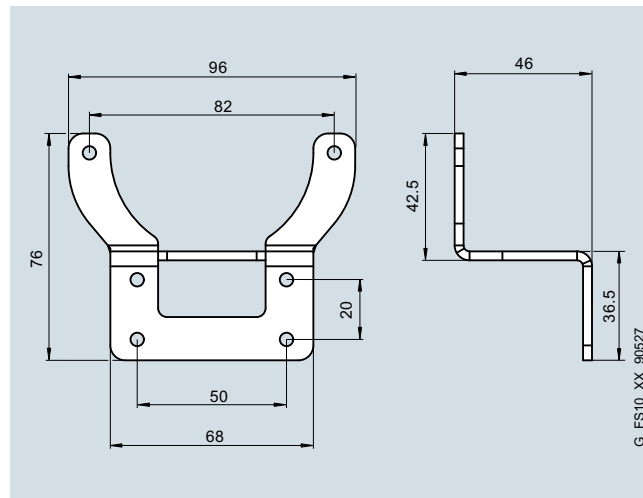

Mounting plate for external ring light

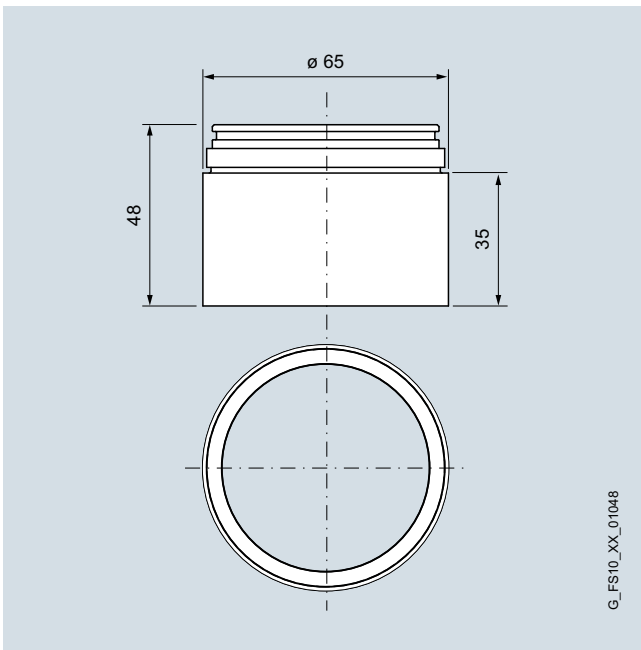

Protective barrel extension for lens D65

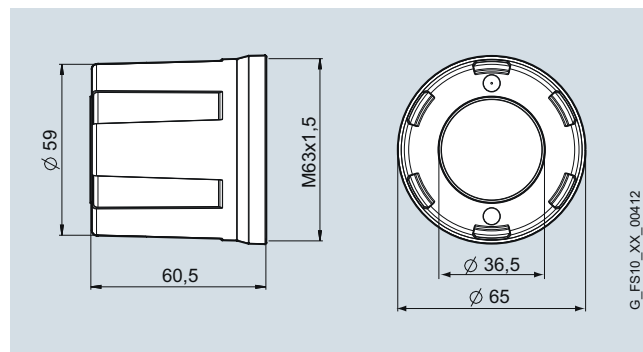

Plexiglas protective barrel

4

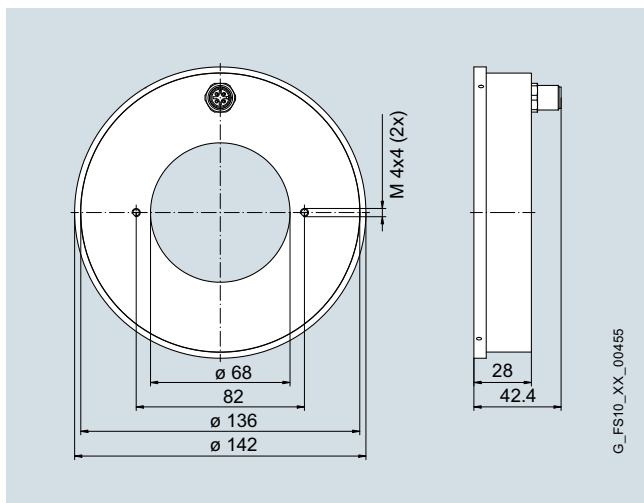

MV400 ring light

Optical identification

Stationary code reading systems

Lenses

Overview



With a lens suitable for the respective image evaluation task, the size of the image field is determined for the camera image for the required operating distance.

High light intensity and the geometry of the image are extremely important for image evaluation (code reading, form recognition and position detection). High light intensity permits short shutter speeds and consequently a reduction of the blurring due to motion as well as maximizing the range.

Lenses with fixed focal length and a settable aperture and focus are ideal for this purpose and are therefore preferred.

Application

Code reading and text recognition

The algorithms of code reading and text recognition tolerate variations in form and size of the marking. In many applications, optical readers must tolerate the influence of perspective distortion. Geometric errors resulting from the imaging often reduce the reading performance of the overall system.

Important selection criteria for the lenses of readers are fast shutter speeds which guard against blurring due to motion, as well as maximization of the reading distance.

All lenses in this accessories list meet the requirements for code reading and text recognition. In addition, lens accessories (e.g. filters) are available which in conjunction with the accessories of the readers support project-specific configurations.

Form recognition and position location

For form recognition with high reproducibility, a format-filling high-resolution image is required. Geometric errors resulting from the imaging often reduce the reading performance of the overall system.

Important selection criteria for the lenses of readers are a short exposure time, which guards against blurring due to motion, as well as maximization of the range. It is particularly important to maximize the range, since the stability of image analysis rises as the angle of the image field reduces. This is why a large distance from the test object is advantageous.

All lenses in this accessories list meet the requirements for shape recognition. In addition, lens accessories (e.g. filters) are available which in conjunction with the accessories of the readers support project-specific configurations.

Function

Image types

The optical path of the lens is defined by its construction.

For **spherical lenses** the solid angle depends on the focal length, focus adjustment, and aperture. All rays run through the focal point of the lens (central projection). Objects that are further away from the lens are depicted smaller. Objects that are closer to the lens are depicted larger:

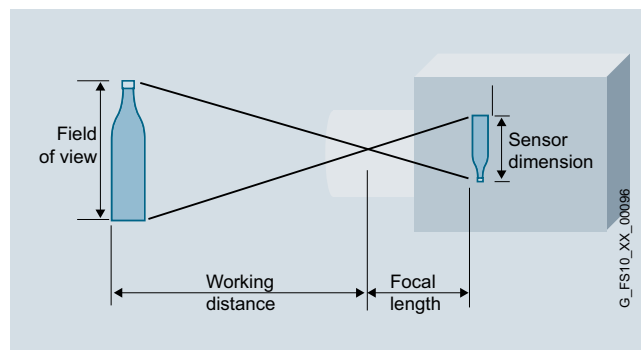

The required image field size (height and width of the image), the size of the sensor chip and the focal length of the lens determine the operating distance:

$$A = (f \times BF) / b$$

d = Operating distance (distance from lens to test object) in mm

f = Focal length of the lens in mm

IS = Size of image in the plane of the test object in mm

b = effective dimensions of the sensor in mm

In the case of lenses used in image processing systems, the focal length is fixed, whereas apertures and focus settings can be fixed. The focal length, the maximum focal aperture and the focusing range are normally specified on the lenses.

Focal distance

The focal length makes a statement about the angle of the image field or the ratio of the size of the real object to the size of the image.

The focal length of the lens is determined by the size of the required image field and the size of the camera chip when a specific distance has to be maintained. The most common chip sizes in cameras today are $\frac{1}{2}$ ", $\frac{1}{3}$ " and $\frac{1}{4}$ ". If the distance to the object lies below the adjustable focusing range of the lens, i.e. at close range, the focus can be adjusted using intermediate rings.

Aperture

Reduction of the light intensity by interrupting the optical path.

Focus

Setting the focus of the lens to a specific distance.

Depth of field

Depth of field is the area within which (in front of and behind the object) that is displayed with sufficient sharpness of focus. The larger the aperture (the smaller the aperture number), the smaller the depth of field.

Lenses with a larger focal length have a smaller depth of field, the effect is considerable for images at close range.

Lens types

Lenses with smaller focal length are called wide-angle lenses, they can also be used at short operating distances, but produce intense distortion of the image. At a suitable given distance, they have a large image field.

Lenses with a long focal length are called telephoto lenses. They have a large magnification but cannot be focused at close range. So macro lenses are used that can be focused by means of large telescopic extensions or intermediate rings. At a given distance, they have a small image field.

In the case of telecentric lenses, at least the optical path at the object end is almost parallel (parallel projection). This means that objects at different distances are depicted in the same size.

Objects can, however, only be displayed that are smaller than the diameter of the lens. It is not possible to adjust the range of focus with these lenses.

The optical characteristics can be restricted by means of optical filter glasses to counteract distortion in the image. Colored filters limit the spectral range, gray filters limit the light intensity and polarization filters restrict the transmission plane. Filters of this type can be attached either by using the internal thread or the flange on the front of the lens. The holder for the filter glass is designed to fit the lens.

Selection and ordering data

	Article No.
C-mount lenses	
With fixed focal length, adjustable aperture and focus, with locking screw.	
<ul style="list-style-type: none"> • Mini lens 6 mm, 1:1.4 D = 32 mm, L = 37.5 mm, MOD = 0.1 m¹⁾ 	6GF9001-1BB01
<ul style="list-style-type: none"> • Mini lens 8.5 mm, 1:1.5 D = 42 mm, L = 47 mm; successor type for 6GF9001-1BE; MOD = 0.2 m¹⁾ Not for use with internal ring lamps. 	6GF9001-1BE01
<ul style="list-style-type: none"> • Mini lens 12 mm, 1:1.4 D = 29.5 mm, L = 35.7 mm; MOD = 0.25 m¹⁾ 	6GF9001-1BL01
<ul style="list-style-type: none"> • Mini lens 16 mm, 1:1.4 D = 29.5 mm, L = 37.2 mm; successor type for 6GF9001-1BF; MOD = 0.25 m¹⁾ 	6GF9001-1BF01
<ul style="list-style-type: none"> • Mini lens 25 mm, 1:1.4 D = 29.5 mm, L = 38.9 mm; successor type for 6GF9001-1BG; MOD = 0.25 m¹⁾ 	6GF9001-1BG01
<ul style="list-style-type: none"> • Mini lens 35 mm, 1:1.6 D = 29.5 mm, L = 41.4 mm; MOD = 0.4 m¹⁾ 	6GF9001-1BH01
<ul style="list-style-type: none"> • Mini lens 50 mm, 1:2.8 D = 29.5 mm, L = 38.0 mm; successor type for 6GF9001-1AH; MOD = 0.9 m¹⁾ 	6GF9001-1BJ01
<ul style="list-style-type: none"> • Mini lens 75 mm, 1:2.8 D = 34.0 mm, L = 63.6 mm; MOD = 0.7 m¹⁾ Not for use with internal ring lamps. If protective tube D60 is used, this lens also requires the protective tube extender (6GF3440-8AC13) which is to be ordered separately. 	6GF9001-1BK01
CS-Mount for C-Mount adapter ring 5 mm	6GF9001-1AP02

¹⁾ MOD = Minimum object distance of the lens – please take the influence of any protective tube into account.

Optical identification

Stationary code reading systems

Lenses

	Article No.
<p>Accessories for utilizing mini lenses at close range</p>	
<p>Set of intermediate rings with 0.5 mm, 1.0 mm, 5.0 mm, 10.0 mm, 20.0 mm and 40 mm rings with 31 mm diameter C thread, to be screwed in between the lens and the camera body for image capture in the macro range.</p>  <p>Illustrations are approximate</p>	6GF9001-1BU
<p>Set of intermediate rings with 0.5 mm and 2 x 1.0 mm rings with 31 mm diameter C thread, to be screwed in between the lens and the camera body for image capture in the close range.</p> 	6GF9001-1BU01
<p>Accessories for utilizing mini lenses in the telephoto range</p>	
<p>Focal length doubler D = 30.5 mm, L = 17.9 mm, with C-thread to be screwed in between the lens and camera to extend the focal length by a factor of 2. Suitable lenses: 6GF9001-1BE01, ...-1BL01, ...-1BF01, ...-1BG01, ...-1BH01, ...-1BJ01, ...-1BK0</p> 	6GF9001-1BV
<p>Filter for utilizing the mini lenses in the limited field of view</p>	
 <p>Infrared filter Function: Visible light is largely or completely filtered out, infrared light can pass through. Application: When used with infrared lamps, it is possible to achieve independence from daylight. Suitable lenses: 6GF9001-1BL01, ...-1BF01, ...-1BG01, ...-1BH01, ...-1BJ01</p>	6GF9001-2AD
<p>Blue filter Function: Blue light can pass through. Application: e.g. to improve the visualization of structures. Suitable lenses: 6GF9001-1BL01, ...-1BF01, ...-1BG01, ...-1BH01, ...-1BJ01</p>	6GF9001-2AE
<p>Polarization filter Function: Filters out light which is directed at right angles to the polarization direction of the filter. Application: e.g. to reduce reflections from metal. Suitable lenses: 6GF9001-1BL01, ...-1BF01, ...-1BG01, ...-1BH01, ...-1BJ01</p>	6GF9001-2AF
<p>Daylight filter Function: Visible light can pass largely undiminished, and frequencies above and below (infrared light and ultraviolet light) are filtered out. Application: The filter is used to protect the image sensor in the camera from laser light to the extent that this is outside the visible spectrum. Suitable lenses: 6GF9001-1BL01, ...-1BF01, ...-1BG01, ...-1BH01, ...-1BJ01</p>	6GF3440-8EA1

Dimensional drawings

Lenses for code reading, text recognition, and object detection

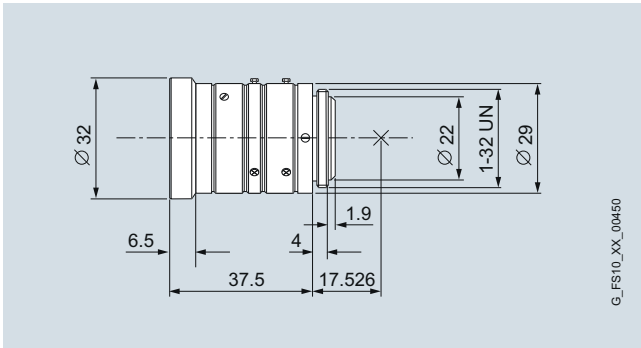

Lens 6GF9001-1BB01

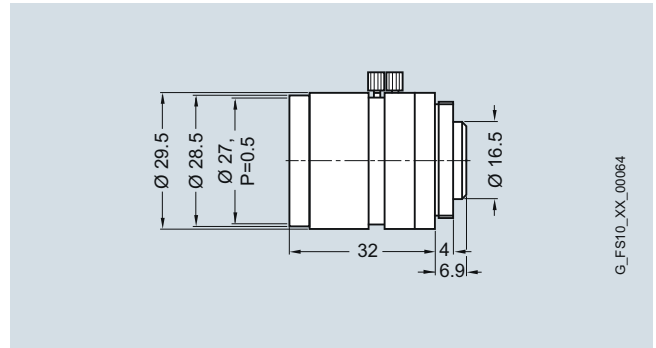

Lens 6GF9001-1BG01

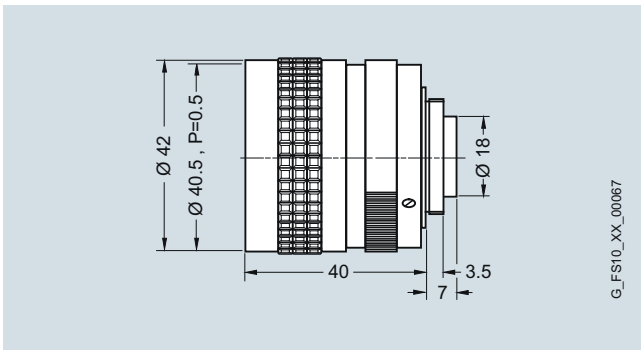

Lens 6GF9001-1BE01

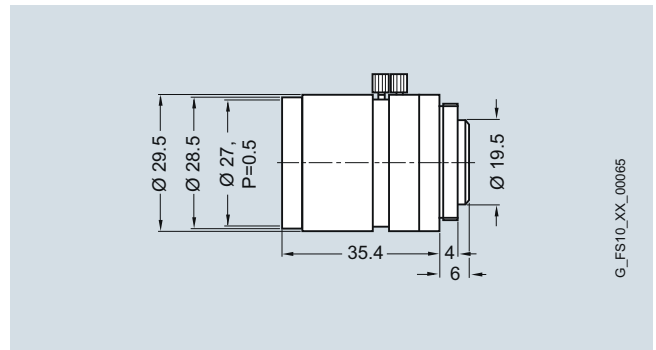

Lens 6GF9001-1BH01

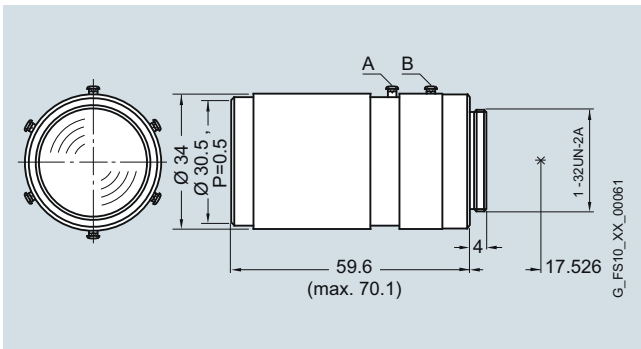

Lens 6GF9001-1BK01

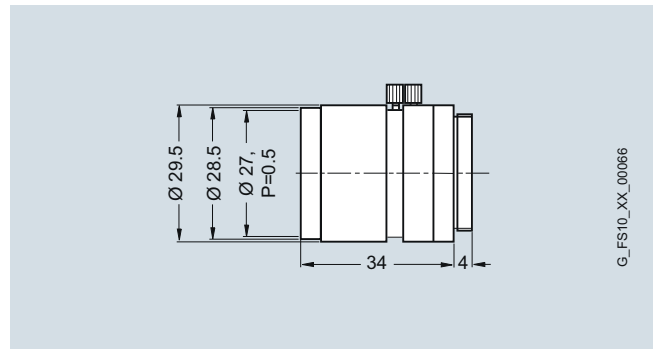

Lens 6GF9001-1BJ01

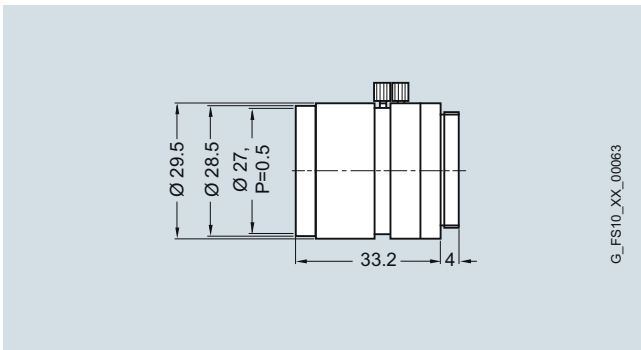

Lens 6GF9001-1BF01

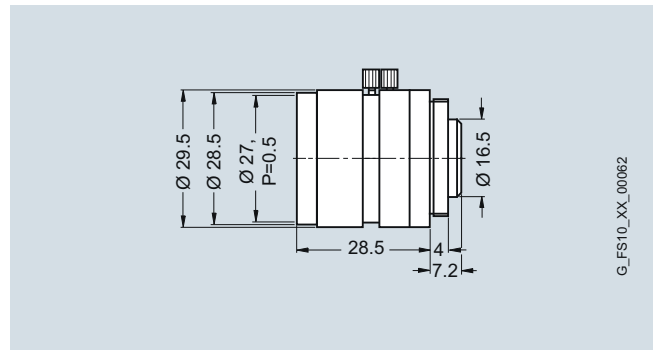

Lens 6GF9001-1BL01

Optical identification

Stationary code reading systems

Lenses

Accessories for lenses

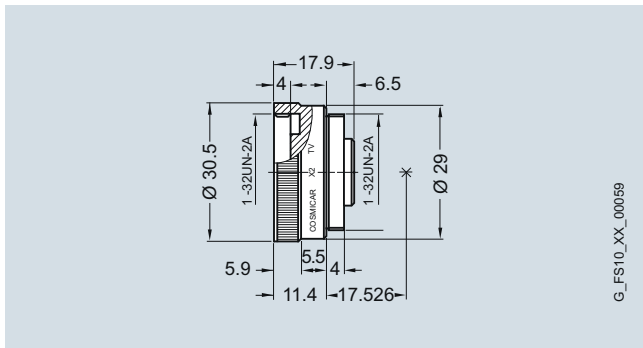

Focal range doubler 6GF9001-1BV

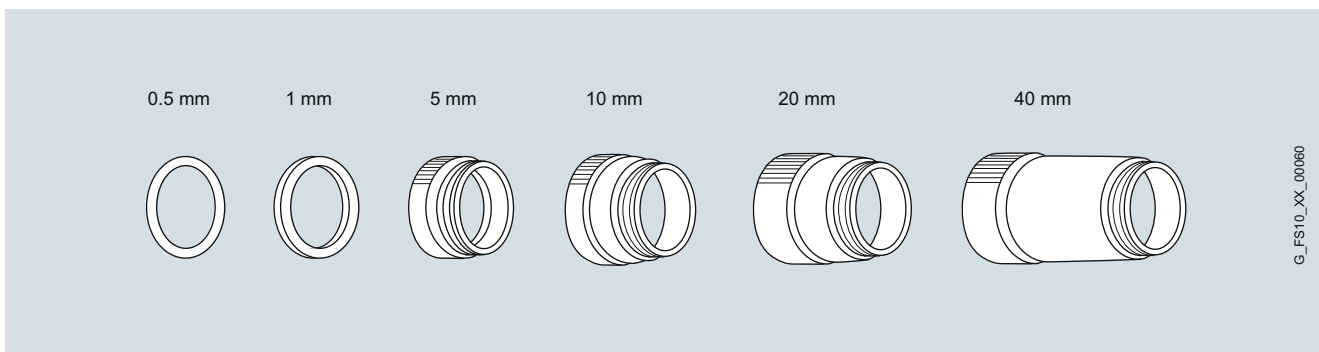

Intermediate ring set 6GF9001-1BU

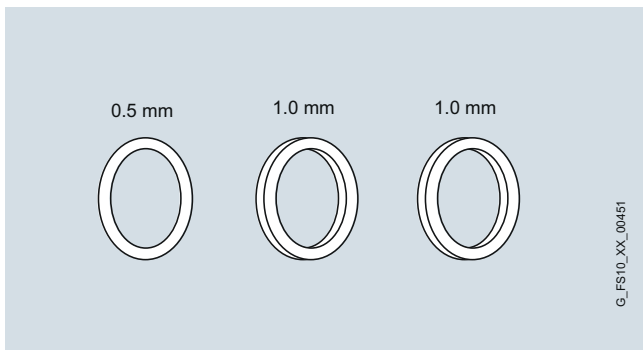

Intermediate ring set 6GF9001-1BU01

Overview

Optical handheld readers are suitable for portable reading of two-dimensional (2D) data matrix codes and one-dimensional (1D) barcodes. The integrated complex image processing functions and illumination technologies enable codes to be read on a variety of surfaces. Optical handheld readers of various performance classes are available for this purpose.

The range extends from devices for simple reading tasks such as printed barcodes up to models for demanding, weak-contrast markings such as dot-peened or lasered codes.



SIMATIC MV320 optical handheld reader

SIMATIC MV320

The SIMATIC MV320 handheld reader is the entry level device. It is suitable for labels with higher contrasts, but it can also be used application-specifically for labels with lower contrasts.

The SIMATIC MV320 is also available as a wired version (RS232, USB). The reader is designed for a distance of up to 375 mm.



SIMATIC MV325 optical handheld reader

SIMATIC MV325

The optical SIMATIC MV325 handheld reader is a high-performance reader with Bluetooth wireless communication. It is suitable for labels with higher contrasts, but it can also be used application-specifically for codes with lower contrasts.

The SIMATIC MV325 is supplied with a charging station containing the respective access point of the wireless interface and a cabled connection to the host (USB). The reader is designed for a distance of up to 375 mm.



SIMATIC MV340 optical handheld reader

SIMATIC MV340

The SIMATIC MV340 is the most powerful device and is particularly suitable for demanding applications such as low-contrast and damaged codes. It has a high reading rate when decoding data matrix symbols.

The special integrated lighting works equally well on smooth, reflective or wavy surfaces. The SIMATIC MV340 can be connected via RS232 or USB. This optical handheld reader is designed for close ranges and records codes at a distance of up to 50 mm.

Optical identification

Handheld reading systems

Introduction

Major differences

Type	SIMATIC MV320	SIMATIC MV325	SIMATIC MV340
Graphic display	–	–	–
Read quality of low-contrast codes	+	+	+++
Operating distance			
• Minimum (code-dependent)	50 mm (1.9")	50 mm (1.9")	0 mm (0.0")
• Maximum (code-dependent)	375 mm (14.8")	375 mm (14.8")	50 mm (2.0")
Field of view			
• Near	25 mm x 15 mm (0.98" x 0.6") at 50 mm (1.9") distance	25 mm x 15 mm (0.98" x 0.6") at 50 mm (1.9") distance	36 mm x 29 mm (1.4" x 1.1") at distance of 0 mm (0.0")
• Distant	150 mm x 90 mm (5.9" x 3.5") at 50 mm (1.9") distance	150 mm x 90 mm (5.9" x 3.5") at 375 mm (14.8") distance	71 mm x 57 mm (2.8" x 2.2") at distance of 51 mm (2.0")
Decoding capability	1D: Codabar, Code 11, Code 32, Code 39, Code 93, Code 128, Interleaved 2 of 5, GS1 DataBar (RSS), Maxtrix 2 of 5, MSI Plessey, Plessey, Straight 2 of 5, Trioptic, UPC/EAN/JAN Stacked 1D: GS1 Composite (CC-A/CC-B/CC-C), MicroPDF, PDF417 2D: Aztec Code, Data Matrix, Micro QR Code, QR Code, Han Xin	1D: Codabar, Code 11, Code 32, Code 39, Code 93, Code 128, Interleaved 2 of 5, GS1 DataBar (RSS), Maxtrix 2 of 5, MSI Plessey, Plessey, Straight 2 of 5, Trioptic, UPC/EAN/JAN Stacked 1D: GS1 Composite (CC-A/CC-B/CC-C), MicroPDF, PDF417 2D: Aztec Code, Data Matrix, Micro QR Code, QR Code, Han Xin	1D: Code 39, Code 93, Code 128, I2of5, Codabar, UPC/EAN, Pharmacode, BC 412 2D: Data Matrix, QR Code, MicroQR Code, PDF417, GS1 Databar, Aztec
Department of Defense Unique Identifier String Validator	–	–	•
Code creation	Print, laser	Print, laser	Laser, print, dot peen
Radio interfaces	–	Bluetooth	–
Ports	USB, RS232	USB	USB, RS232

Benefits



- Industry leading reading performance for Data Matrix codes, also for hard-to-read DPMs.
- Rugged design, for production environment.
- Supports multiple communication protocols: RS232 / USB or Bluetooth.
- Can read barcodes, data matrix codes, and other symbols.
- Can be used as a replacement device for existing barcode readers.

Application

The optical handheld readers are suitable for optical identification of objects using 1D or 2D codes in the production, logistics, quality assurance, and maintenance and servicing fields. Application examples:

- Automotive industry
 - Markings on various drive components (cylinder heads, cylinder blocks, elbow joints, etc.)
 - Laser markings on various drive components (cam shafts, crankshafts, pistons, piston rods, gearbox components, etc.)
 - Laser markings on electronic components, printed circuit boards, or enclosures
- Mechanical engineering
 - Markings on different types of component
- Tobacco industry
 - Printed or laser markings on boxes
- Food industry
 - Printed or laser markings on cartons
 - Laser markings on production machines

Design

All handheld readers are equipped with a handle. The handles are equally suitable for right-handed or left-handed persons. The read process is triggered by a switch on the handle. The handle can be removed. On cabled connections via RS232 or USB, data and power are transmitted direct via the shared cable.

Overview



SIMATIC MV320 is a rugged, powerful industrial barcode and data matrix code reader suitable for high resolutions. This handheld reader reads two-dimensional (2D) data matrix codes and one-dimensional (1D) barcodes.

It can read medium to high contrast data matrix codes. The cell size should be larger than 0.13 mm. Barcodes can be read if the width of a bar is larger than 0.12 mm.

The reader possesses complex image processing functions and illumination technology in order to read codes on many different surfaces.

The SIMATIC MV320 handheld reader is suitable for wired communication. Due to the varied interface technology (USB, RS232), simple integration into your application is possible with the device.

The optical SIMATIC MV320 handheld reader is supplied as a package including USB cable. A separate package comprising cable and power supply is available for use as an RS232 version.

Design

The SIMATIC MV320 handheld reader features a robust, ergonomic handle with integrated strain relief.

The SIMATIC MV320 is a monolithic product and thus extremely robust. The only replaceable component is the cable that is connected to the reader with protected strain relief but can nevertheless be easily replaced for the purpose of changing the interface technology.

Integration

The SIMATIC MV320 handheld readers can communicate with the host computer by means of RS232 and USB. No special software is required for this purpose. The SIMATIC MV320 is configured by reading supplied data matrix codes.

The optical handheld reader can only be operated via RS232 and USB for direct transfer of the codes to the host computer. "Batch mode" is not possible.

Technical specifications



Article number	6GF3320-0HT01
Product type designation	MV320 optical handheld reader
Suitability for operation	1D/2D: Aztec, Codabar, Codablock F, Code 11, Code 39, Code 39 Short Margin, Code 39 Extended Full ASCII, Code 39 Checksum, Code 93, Code 128, Code 128 Short Margin, Composite, Data Matrix, Data Matrix Rectangle, Data Matrix Inverse, GS1 DataBar (all), Interleaved 2of5, Interleaved 2of5 - 2 Digits, Macro PDF417, Maxicode, Matrix 2of5, Micro PDF417, MSI Plessey, NEC 2of5, OCR, PDF417, Postal Codes (All), QR Code, Telepen, UPC, UPC Short Margin, UPC Extension
Range	20 ... 375 mm
Range Note	Range depends on the type and size of code. See manual for details
Optical data	
Design of image sensor of the camera	CMOS 1 280 x 960, image resolution 960 x 640
Mounting type of lens	Integrated
Type of light source	Lighting system comprising incident light (red)
Image acquisition frequency maximum	10 Hz
Type of focusing	Fixed focus, optimum focal point at 6.3 mm
Supply voltage, current consumption, power loss	
Type of current supply	Via USB or external plug-type power supply unit (RS232), 5 V, 410 mA
Type of battery	--
Permitted ambient conditions	
Ambient temperature	
• during operation	-20 ... +55 °C
• during storage	-30 ... +65 °C
Relative humidity at 25 °C without condensation during operation maximum	95 %
Height of fall maximum	1.8 m
Design, dimensions and weight	
Width	132 mm
Height	52 mm
Depth	92 mm
Net weight	0.13 kg
Product properties, functions, components general	
Design of the display	2 LEDs
Operator element version	Trigger in handle
Design of acoustic signaling element	Vibration alarm, audible signal
Design of the interface	USB, RS232
Product functions management, configuration	
Product function of the software	Read, display, save, transfer codes
Type of programming	Optical parameterization or via configuration software
Accessories	
Accessories	RS232 cable with power supply, USB cable, metal stands

Optical identification

Handheld reading systems

SIMATIC MV320

Selection and ordering data

	Article No.
SIMATIC MV320 Rugged industrial handheld reader for barcodes and data matrix codes, with 1.8 m USB cable. 	6GF3320-0HT01
Accessories	
USB cable 1.8 m long, not spiraled	6GF3320-0AC02
RS232 cable 2.4 m long, spiraled 	6GF3320-0AC03
Plug-in power supply For use with RS232 cable <ul style="list-style-type: none"> • For the USA • For Europe 	6GF3020-0AC40-0AP1 6GF3020-0AC40-0AP2
Metal stands 	6GF3320-0AC07

Dimensional drawings

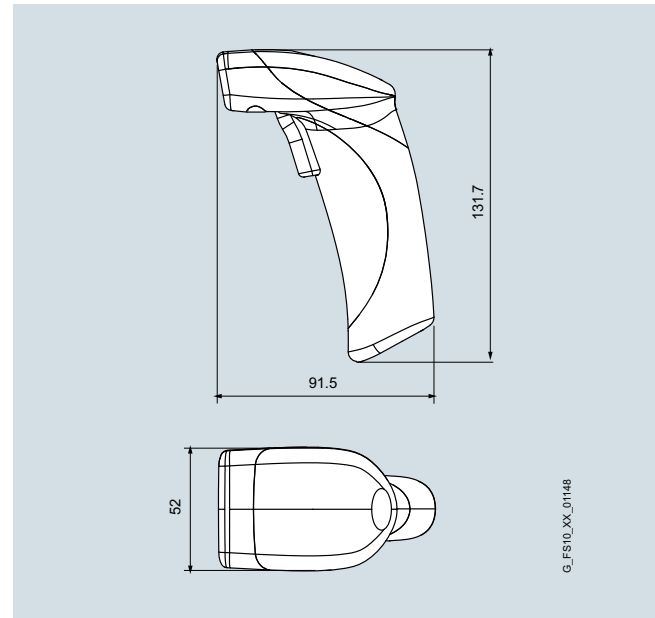

SIMATIC MV320 optical handheld reading device

Overview

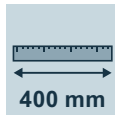

The SIMATIC MV325 handheld reader is a robust, high-performance industrial barcode and data matrix code reader suitable for high resolutions. It reads two-dimensional (2D) data matrix codes and one-dimensional (1D) barcodes.

Medium to high contrast data matrix codes can be read. The cell size should be larger than 0.13 mm. Barcodes can be read if the width of a bar is larger than 0.12 mm.

The reader possesses complex image processing functions and illumination technology in order to read codes on many different surfaces.

The SIMATIC MV325 handheld reader is suitable for wireless communication. Thanks to Bluetooth interface technology, simple integration into your application is possible with the device.

The handheld reader is supplied as a package including a charging station and USB cable.

Design

The optical SIMATIC MV325 handheld reader has a replaceable battery pack and is extremely rugged. The only replaceable component is the battery that can be charged together with the reader or individually in the charging station.

Integration

The charging station of the SIMATIC MV325 can communicate with the host computer by means of USB. No special software is required for this purpose. The SIMATIC MV325 is configured by reading supplied data matrix codes.

The SIMATIC MV325 handheld reader itself communicates via Bluetooth with the base station. No special software is required for connecting a handheld reader with a specific charging station since the SIMATIC MV325 is connected with the charging station by reading a unique identifier on the charging station.

The code contents read are automatically transferred to the charging station as soon as a wireless connection is established. If the connection to the charging station is not established, the read results are buffered in the mobile section (if this function is activated). This operating mode is referred to as batch mode. As soon as the connection to the charging station is restored, the read results are automatically transferred.

Optical identification



Handheld reading systems

SIMATIC MV325

Technical specifications

Article number	6GF3325-0HT01
Product type designation	MV325 optical handheld reader
Suitability for operation	1D: Codabar, Code 11, Code 32, Code 39, Code 93, Code, 128, Interleaved 2 of 5, GS1 DataBar (RSS), Maxtrix 2of5, MSI Plessey, Plessey, Straight 2of5, Trioptic, UPC/EAN/JAN Stacked 1D: GS1 Composite (CC-A/CC-B/CC-C), MicroPDF, PDF417 2D: Aztec Code, Data Matrix, Micro QR Code, QR Code, Han Xin
Range	20 ... 375 mm
Range Note	Range depends on the type and size of code. See manual for details
Optical data	
Design of image sensor of the camera	CMOS 1 280 x 960, image resolution 960 x 640
Mounting type of lens	Integrated
Type of light source	Lighting system comprising incident light (red)
Image acquisition frequency maximum	10 Hz
Type of focusing	Fixed focus, optimum focal point at 6.3 mm
Supply voltage, current consumption, power loss	
Type of current supply	Battery operation
Type of battery	Lithium ion accumulator, fast charging capability
Battery capacity	1.3 Ah
Operating period with standard battery typical	12 h
Permitted ambient conditions	
Ambient temperature	
• during operation	-20 ... +55 °C
• during storage	-30 ... +65 °C
Relative humidity at 25 °C without condensation during operation maximum	95 %
Height of fall maximum	1.8 m
Design, dimensions and weight	
Width	135 mm
Height	51 mm
Depth	130 mm
Net weight	0.18 kg
Product properties, functions, components general	
Design of the display	6 LEDs
Operator element version	Trigger in handle
Design of acoustic signaling element	Vibration alarm, audible signal
Design of the interface	Bluetooth Class 2, USB
Product functions management, configuration	
Product function of the software	Read, display, save, transfer codes
Type of programming	Optical parameterization or via configuration software
Accessories	
Accessories	Changeable accumulator for 50000 readings (Lion 3.7 V / 1.3 Ah), external charging station (power supply via USB) incl. Bluetooth Accesspoint

Selection and ordering data

	Article No.
SIMATIC MV325	6GF3325-0HT01
Robust industrial optical handheld reader for 1D and 2D codes (e.g. barcodes and data matrix codes), with charging station and USB cable. With Bluetooth wireless interface and charging station with USB host interface.	
Accessories	
Charging station	6GF3325-0AC03
Charging station with USB host interface and with Bluetooth wireless interface. With USB cable (0.9 m).	
	
Battery	6GF3325-0AC07
Lithium ions (1300 mAh; 50 000 charging cycles)	
	

Dimensional drawings

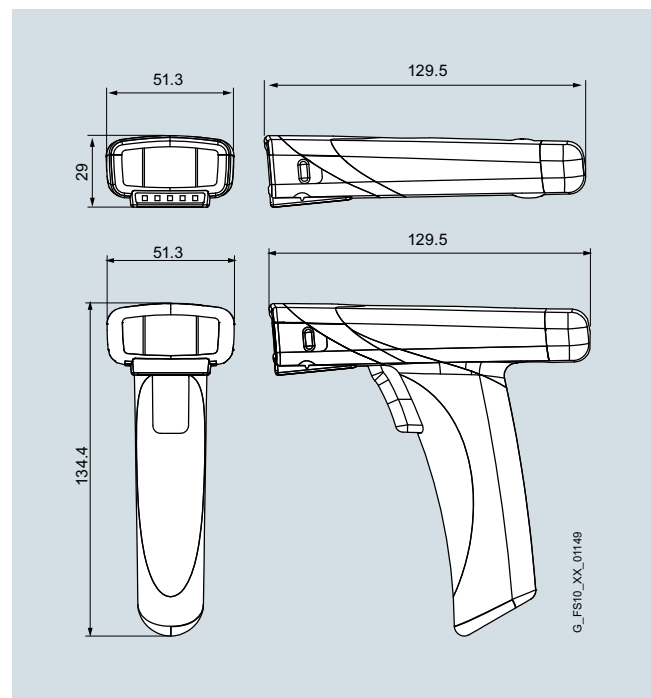

SIMATIC MV325 optical handheld reading device

Overview

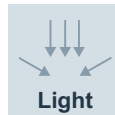
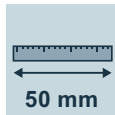

The SIMATIC MV340 is one of the most powerful handheld readers in the world and is thus particularly suitable for demanding applications. The reader reads a wide range of direct part markings (DPM), from linear barcodes all the way to 2D symbols. Different codes can be read without having to reconfigure the device.

The optical MV340 handheld reader is designed for close ranges and records codes at a distance of up to 50 mm. The optimum reading distance is 6 mm. The special integrated lighting is ideal for a wide variety of surfaces and increases the contrast with stamped codes. Low-contrast reading despite fluctuating lighting conditions and twisted or damaged codes are the strengths of the SIMATIC MV340.

The SIMATIC MV340 handheld reader is connected via a USB or RS232 interface to the IT system or HMI device.



Design

The SIMATIC MV340 is a fully integrated device that combines a powerful reader unit and lighting in a rugged housing with an ergonomically shaped handle. The read process is triggered by a switch on the handle. Feedback from the read process can be optical via a multi-color LED, acoustic, or by means of a vibrating alarm.

The special integrated lighting unit can switch automatically between different lighting types to always provide optimal lighting conditions for a wide range of code and surface types. Even low-contrast codes or dot peen markings are therefore no longer a problem.

The device is supplied with a USB cable as standard. An RS232 cable can be ordered separately as an accessory.

Integration

The SIMATIC MV340 is connected via USB or RS232. The free ESP software is available for user-friendly set-up of the device. As an alternative, the device can be installed and operated without special software since it can also be configured by reading supplied data matrix codes.

The power supply is solely via cable. If the device is connected via USB to the host computer, the supply voltage is applied directly via the USB port. Connection to the RF170C communication module is also via the USB port. If the connection is via RS232, an additional power supply unit is required which is coupled to the RS232 connector via Y-cable. The power supply unit is available in three variants: EU, UK, and USA.

Optical identification

Handheld reading systems

SIMATIC MV340

Technical specifications

Article number	6GF3340-0HT01
Product type designation	MV340 optical handheld reader
Suitability for operation	1D Codes: Int. 2/5, Code 128, Code 93, Code 39, EAN/UPC, Codabar, BC 412 2D-Codes: DMC, PDF417, QR, GS1 Databar
Range	0 ... 50 mm
Range Note	Code-dependent
Optical data	
Design of image sensor of the camera	CMOS 1 280 x 1 024
Mounting type of lens	Integrated
Type of light source	Lighting system comprising diffuse incident light (light field: red/blue) and dark field (red)
Image acquisition frequency maximum	10 Hz
Type of focusing	Fixed focus, optimum focal point at 6.3 mm
Supply voltage, current consumption, power loss	
Type of current supply	Via USB or external plug-type power supply unit (RS232), 5 V, 410 mA
Type of battery	--
Permitted ambient conditions	
Ambient temperature	
• during operation	0 ... 50 °C
• during storage	-20 ... +65 °C
Relative humidity at 25 °C without condensation during operation maximum	95 %
Height of fall maximum	1.8 m
Design, dimensions and weight	
Width	180 mm
Height	63 mm
Depth	114 mm
Net weight	0.2 kg
Product properties, functions, components general	
Design of the display	Multi-color LED
Operator element version	Trigger in handle
Design of acoustic signaling element	Vibration alarm, audible signal
Design of the interface	USB, RS232
Product functions management, configuration	
Product function of the software	Read, display, save, transfer codes
Type of programming	Optical parameterization or via configuration software
Accessories	
Accessories	RS232 cable with power supply

Selection and ordering data

	Article No.
SIMATIC MV340	6GF3340-0HT01
Robust industrial optical reader for barcodes and data matrix codes, with special integrated lighting. Suitable for demanding, i.e. low-contrast, marking systems. With USB cable.	
Accessories	
RS232 cable	
• 2.4 m long, spiraled.	6GF3020-0AC40-0AC1
• 2.4 m long, spiraled, with power supply for USA.	6GF3020-0AC40-0AC3
• 2.4 m long, spiraled, with power supply for Europe.	6GF3020-0AC40-0AC4
• 2.4 m long, spiraled, with power supply for UK.	6GF3020-0AC40-0AC5
• 5 m long, spiraled.	6GF3020-0AC40-0AC7
• 5 m long, spiraled, with power supply for Europe.	6GF3020-0AC40-0AC8
USB cable	6GF3020-0AC40-0AC0
1.8 m long, not spiraled.	
Power supplies	
For use with RS232 cable	
• For USA.	6GF3020-0AC40-0AP1
• For Europe.	6GF3020-0AC40-0AP2

Dimensional drawings

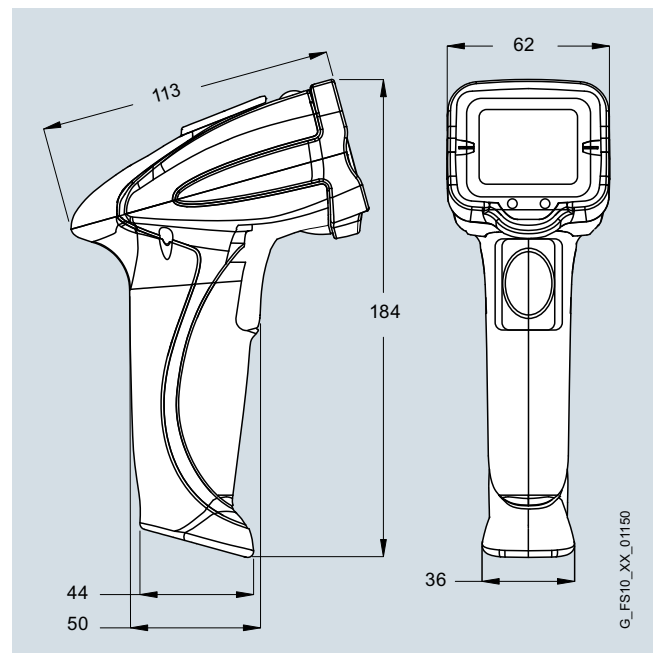

SIMATIC MV340 optical handheld reading device

Overview

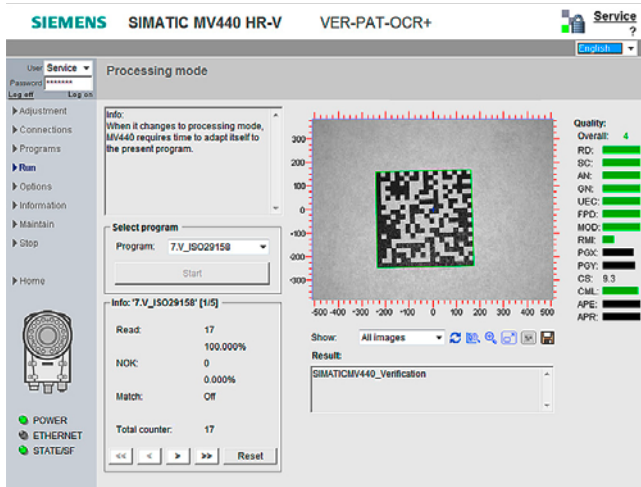

Marking a product is normally done very early on in the production process so that all following steps can be controlled using the product identity.

By using verification systems, the readability of marks is guaranteed throughout the entire production process regardless of any possible contamination or when using different read devices. Moreover, the marking can continue to be read after the production process throughout the lifespan of the product.

With the verification license "Veri-Genius", devices of the SIMATIC MV440 family can be used for checking the marking quality of codes (verification) in addition to reading 1D barcodes and 2D matrix codes.

The license is supplied as a "Single License" on a USB flash drive and can be installed via the SIMATIC Automation License Manager (ALM) on any reader of the SIMATIC MV440 series. The license is executable on a SIMATIC MV440 as of firmware version 4.0.

Benefits



Support for all important sectors and code types through the following verification standards:

- ISO TR 29158 (previously AIM DPM-1-2006)
 - Code type: Data Matrix Code
 - Type of marking: All - focus on DPM, e.g. dot-peened and lasered markings
 - Industries: All - focus on DPM, e.g. dot-peened and lasered markings
- Siemens DPM
 - Code type: Data Matrix Code
 - Type of marking: All - focus on DPM, e.g. dot-peened and lasered markings
 - Industries: All
- ISO/IEC 15415
 - Code type: Data Matrix Code
 - Type of marking: Printed
 - Sectors: All – focus: Pharmaceutical industry
- AS9132 Rev. A (previously IAQG)
 - Code type: Data Matrix Code
 - Type of marking: Printed
 - Sectors: All – focus: Aerospace
- ISO/IEC 15416 (previously ANSI X3.182-1990)
 - Code type: Barcode
 - Type of marking: Printed
 - Sectors: All - printed labels

Further highlights

- Various resolutions available (640 x 480 pixels, 1 024 x 768 pixels and 1 600 x 1 200 pixels)
- License includes calibration card
- Simultaneous reading and verifying in one field of view
- Flexible retrofitting of the license to each device of the SIMATIC MV440 series via the Automation License Manager of SIMATIC – advantage: Savings with stocking spare parts
- Easy integration of verification into the automation environment via SIMATIC MV440 using a function block (FB 79, FB 45 and Ident profile).

Optical identification

Verification systems

Veri-Genius for MV440

Application

Applications for verification span across almost all sectors. To maximize read rates in production and logistics and to make them predictable, it is essential to measure the marking quality.

The following sectors and applications are a particular focus for MV440 verification systems:

Automotive industry

- Needle marking (DPM):
e.g. cylinder heads, cylinder blocks, etc.
- Laser marking (DPM):
Cylinder pistons, gearbox components, etc.
- Laser markings on electronic components,
printed circuit boards, or enclosures

Pharmaceutical industry

- Print or laser markings on medicines (DPM, OCR)
- Aerospace industry
- Needle or laser markings on gas turbine blades (DPM)
- Needle or laser markings on jet engine components (DPM)

Medical equipment

- Laser markings on implants (DPM)
- Laser markings on medical devices (DPM).

Electronics

- Needle or laser markings on hard disk components.
- Laser or etched markings on hard disk components (DPM)

Semiconductors

- Laser markings on rigid and flexible circuit boards (DPM)
- Laser markings on enclosed semiconductor components,
heat sinks or heat exchangers (DPM)

"Veri-Genius" can be used anywhere where ambient conditions permit the use of the MV440 optical reader - for details, see SIMATIC MV440. Standard ring lights and lenses are designed to achieve IP67 degree of protection by means of the protective barrel, and for glass-free use in the food and beverages industry. If light sources or lenses are used outside the protective barrel, they must be used in compliance with their specification.

Any host and HMI systems required must be selected for a sector and a specific project. The range of application of the selected test method is defined in the specification of the test method and compliance is essential if universally valid results are to be obtained.

Design

All stationary optical SIMATIC MV440 readers are basic units under the terms of the "Veri-Genius" license. The verification functionality is enabled by transferring the license key from the supplied USB flash drive to the optical MV440 reader by means of SIMATIC License Manager.

The functionality is available without a license in demo mode. The functions subject to licensing are fully available without performance restrictions in Demo mode. Only output of the results on the communication channels is disrupted. Users can therefore determine in Demo mode if the functions and performance fulfill their requirements.

Verification with MV440 verification systems is suitable for both inline and offline measurements. In both cases, the specification of the verification standard used must be observed to ensure a robust measurement result. This means that, for example, the lighting and alignment of the light source, camera and test object must be selected in accordance with the specifications of the respective standard.

If only one light source is used, the MV440 can control an external light source using the existing image-synchronized digital output, or the external light source can be operated continuously.

If more lighting directions are required, an external controller can be used to activate the desired lighting and to start each individual measurement by means of triggering. The result from the quality measurement or the relevant partial measurement is output directly by the MV440 after completion of the measurement. In the case of more than one measurement, it is the task of the external controller to combine the partial results into an overall result and to visualize this.

For a measurement with only one type of lighting, the measurement result can be visualized directly as a verification report in the form of an HTML page which can then be printed out.

If the test method requires calibration, the calibration card included in the scope of delivery can be used in most cases. In cases with extreme imaging requirements (e.g. with very small or very large codes), the task of calibration must be resolved application-specifically.

Function

The following typical types of fault can be detected by measuring the marking quality - the following pictures show examples of correct code and faults in the marking quality:

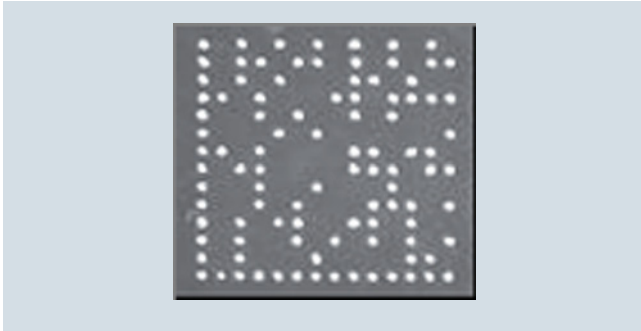

Correct code

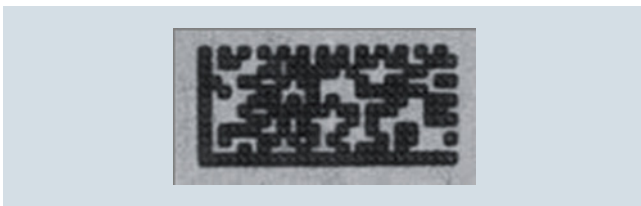

Incorrect or non-uniform cell size in the marking

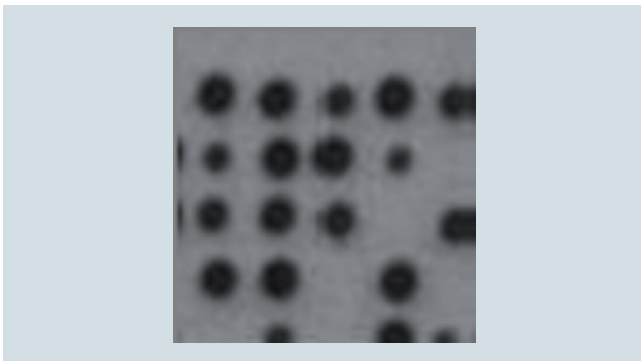

Incorrect or non-uniform cell size in the marking

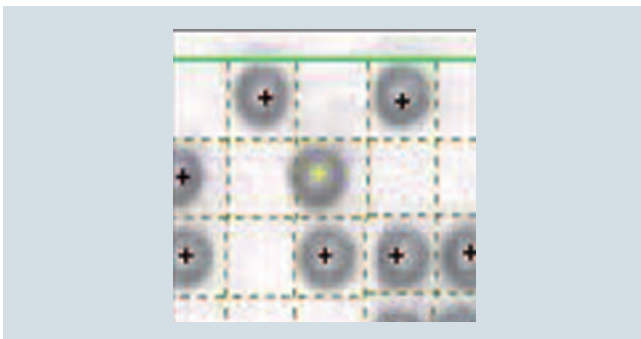

Incorrect or non-uniform cell position in the marking

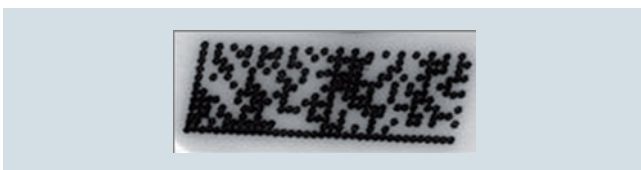

Incorrect overall geometry of the marking



Damaged surface of the marking or part



Very little or non-uniform contrast in the marking



Very little or non-uniform contrast in the marking

The following measuring procedures/standards are available for the purposes of inspection:

- ISO TR 29158 (previously AIM DPM-1-2006)
- Siemens DPM
- ISO/IEC 15415
- AS9132 Rev. A (previously IAQG)
- ISO/IEC 15416 (previously ANSI X3.182-1990)

Optical identification

Verification systems

Veri-Genius for MV440

The measurement result is output as an overall result in 5 stages, which are named using letters or numbers:

Overall result as a digit	Overall result as letters	Overall result as text
4	A	Top quality
3	B	Good quality
2	C	Satisfactory quality
1	D	Adequate quality
	E	(not used)
0	Fault	Marking quality inadequate

The components of a measurement result and calculation of the overall result are dependent on the test method used.

The overall result and the components of a measurement result can be output after a test, and are then available for further processing on an external system, e.g. for archiving or creating a test report.

Integration

The MV440 verification systems can use all communication services that the SIMATIC MV440 basic unit offers:

Usable communication services	
PROFINET IO (FB 79)	Onboard MV440 PROFINET interface.
PROFINET IO (FB 101, Ident profile)	Onboard MV440 PROFINET interface.
PROFINET IO (FB 45, FB 101, Ident profile)	Via MV440 communication module interface, using the RF180C communication module.
Ethernet/IP	Via communication module interface, with communication module RFID 181EIP.
PROFIBUS DP V0/1 (FB 45, Ident profile)	Via MV440 communication module interface, using the ASM 456 communication module.
TCP/IP native	Onboard MV440 PROFINET interface.
RS232 (ASCII)	Onboard MV440 RS232 interface.
SIMATIC S7-1200, S7-300, ET 200pro	Via communication module interface.

The most important types of interface in the automation environment are shown in the overview below.

Refer to the section on the SIMATIC MV440 for additional details.

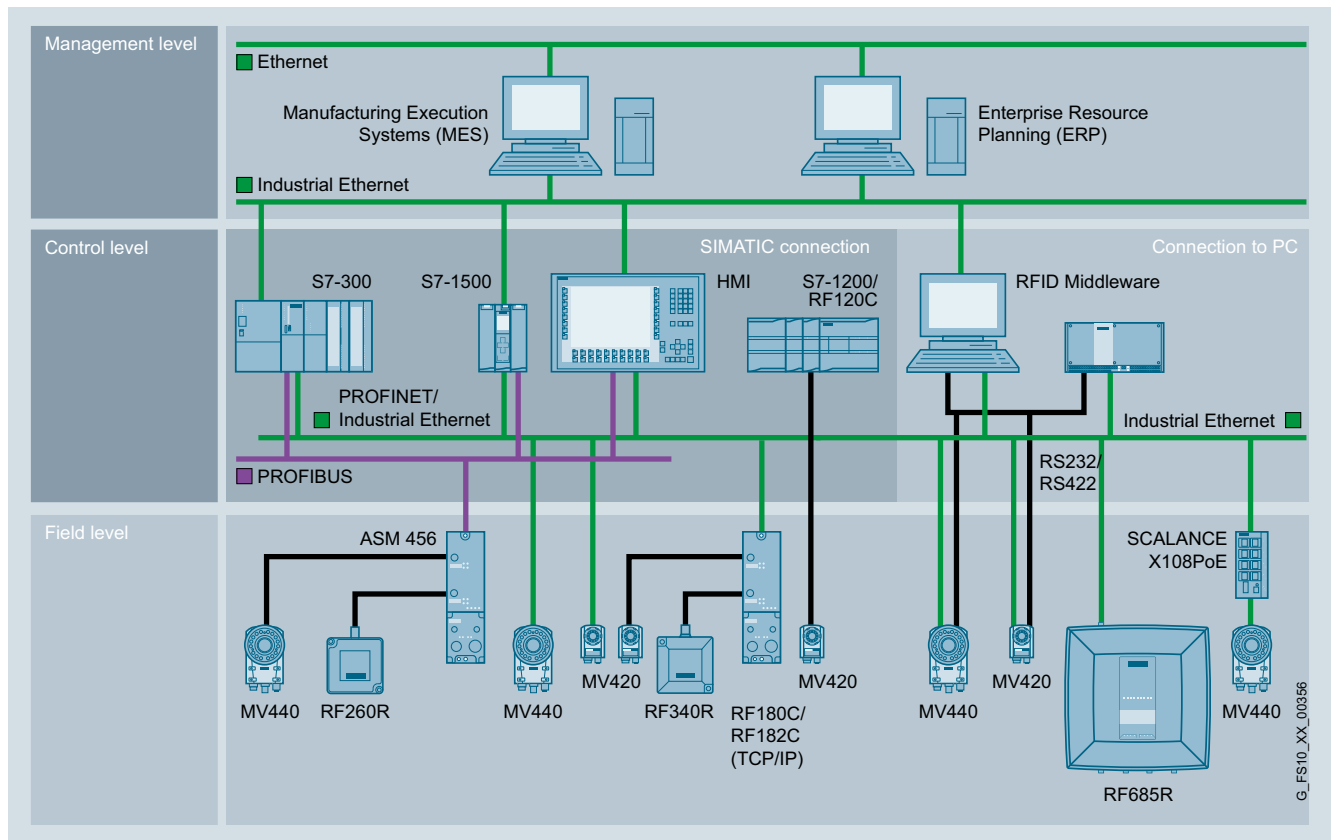

Selection and ordering data

	Article No.
Verification module Veri-Genius Software license for verification of machine-readable 1D barcodes and Data Matrix Codes. The license is supplied on a USB flash drive; executable on all optical SIMATIC MV440 readers as of firmware V4.0 (SIMATIC MV440 not included in the scope of delivery). The scope of supply includes the calibration card.	6GF3400-0SL02
Calibration card Spare part	6GF3440-8CE

Optical identification

Optical character recognition (OCR)

Text-Genius for MV440

Overview

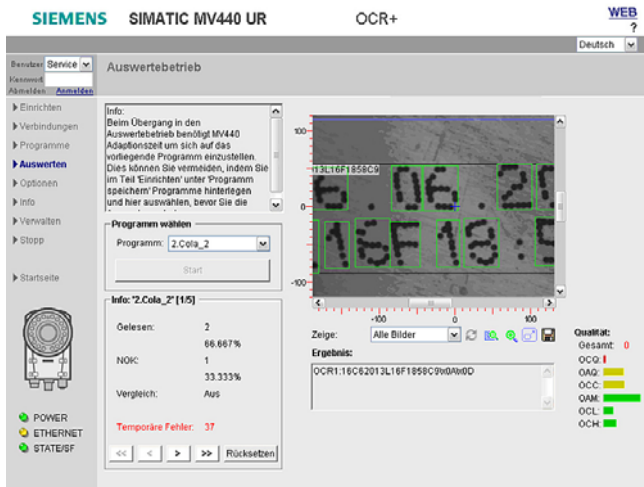

With the "Text-Genius" and "Text-Genius Plus" licenses, SIMATIC MV440 can be used for text recognition (in addition to reading 1D barcodes and 2D matrix codes).

Text recognition is also referred to as OCR (Optical Character Recognition). Simultaneous reading and comparing of plain text and reading of machine-readable codes in the same field of view is thus possible.

"Text-Genius" allows text recognition without training for a number of character sets by using generic algorithms, and thus reading without a preparatory phase.

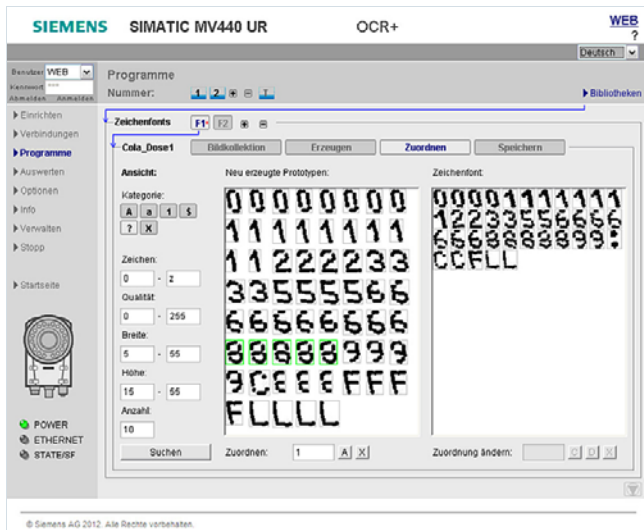

Text-Genius Plus

The "Text-Genius Plus" license comprises all functions of the "Text-Genius" license and additionally enables training of further fonts and characters, including special characters and graphic symbols.

Licenses

The licenses are supplied as a "Single License" on a USB flash drive and can be copied to the device with the SIMATIC Automation License Manager (ALM) using a plug-in. The "Text-Genius" license is executable on a SIMATIC MV440 with firmware version 3.0 and higher, the "Text-Genius Plus" license with Firmware version 5.0 and higher.

Benefits



Highlights of Text-Genius and Text-Genius Plus at a glance

- Quick and reliable reading (up to than 2000 readings per minute depending on the application) for high-speed applications.
- Fast and reliable checking of the readability of plain text (up to 1 000 reads per minute) for high-speed applications.
- Flexible reading and swapping between different fonts (e.g. OCR A, OCR B) without complex learning using Polyfont character set.
- High reading rate and reliability through saving of fonts on the camera.
- Reading and comparison of plain text and machine-readable code in the same image field.
- Automatic position tracking of the reading range with the resources of "Pat-Genius".
- Automatic text localization without the use of predefined areas means that text can be read even when its position varies.
- Automatic line detection for max. 12 freely definable image regions with max. 15 lines.
- Automatic character height recognition between 15 and 220 pixels.
- Individual parameterization per image region.
- Reading of mirrored, 90° rotated, and inverted text.
- Numerous filter and comparison functions.
- Comparison of text recognition result with an individually specified text per read operation.
- Flexible retrofitting of the text recognition function via the SIMATIC Automation License Manager
- Simple integration in the automation environment, e.g. via function block of the SIMATIC MV440 devices.

Additional highlights of Text-Genius Plus:

- Simple training of additional characters and fonts (user fonts).
- Adaptation of text recognition by user fonts to the specific requirements of the application to enable:
 - Expansion of defined fonts by missing characters, e.g. special characters.
 - Optimization of recognition for specific printing procedures (e.g. laser, ink, scribed, needled).
 - Optimization of recognition by using different versions of individual characters, e.g. to compensate distortions.
- Up to five user fonts can be used in the reader.
- Very high read reliability can be achieved (> 99.5%).

Application

Applications for text recognition span across almost all sectors. The application areas can be generally divided in three task areas:

- Text recognition for recording the content of a plain text identification.
- Comparison of the content of a plain text identification with the content of the adjacent machine-readable identification, e.g. Data Matrix Code (DMC).
- Comparison of the content of a plain text identification with individually specified values which are transferred to the reader similar to a printer.

Applications for different sectors are listed below. The list is incomplete and only serves to illustrate the wide range of possible applications.

Automotive industry, aerospace industry

- Detection and checking of plain text identifiers for type identification of components
- Comparison of DMC and plain text
- Acquisition of a unique identification of a product (serialization)
- Acquisition and checking the expiry date

Medical equipment

- Laser markings on implants (DPM)
- Laser markings on medical devices (DPM).

Electronics

- Detection of a unique plain text identifier for identifying devices, e.g. electricity meters
- Detection and checking of plain text identifiers for type identification of PCBs
- Solar industry (serial numbers on thin-layer modules)
- Detection of a unique plain text identifier on thin-layer modules (serialization)

Food and beverage industry

- Inspection of expiry date on packaging
- Control of packaging and storage processes

"Text-Genius" and "Text-Genius Plus" can be used anywhere where ambient conditions permit the use of the optical reader SIMATIC MV440. For details, see "SIMATIC MV440". Standard ring lights and lenses are designed to achieve IP67 degree of protection by means of the protective barrel, and for glass-free use in the food and beverages industry. If light sources or lenses are used outside the protective barrel, they must be used in compliance with their specification.

The "text recognition" function can be implemented in applications without the need to consider the type of font used for marking (Polyfont) or the marking method. The fonts which enable a maximum read rate to be achieved are listed in the "Function" chapter. Further fonts and additional characters can be added to Text-Genius Plus at any time by training. No marking methods are excluded either. The read rate improves if the font has a stable appearance and when there is a good contrast between the background and marking.

Design

All stationary optical SIMATIC MV440 readers are basic units under the terms of the "Text-Genius" and "Text-Genius Plus" licenses. The text recognition functionality is enabled by transferring the license key from the supplied USB flash drive to the MV440 reader by means of SIMATIC License Manager.

The functionality is available without a license in demo mode. The functions subject to licensing are fully available without performance restrictions in Demo mode. Only output of the results on the communication channels is disrupted. Users can therefore determine in Demo mode if the functions and performance fulfill their requirements.

Function

The outstanding feature of "Text-Genius" and "Text-Genius Plus" is that they are easy to set up. To achieve stable read results for text recognition, it is only necessary to set a few, simple parameters. "Text-Genius" uses a generic approach for text recognition, so no individual training is required for most fonts and the characters (letters and digits) of the ASCII character set. Recognition of several fonts is thus possible with this software without specific training. In particular, no complex settings are required for optimizing recognition performance.

The following fonts are ideal for recognition of the text:

- OCR-A
- Semifont M13
- and similar fonts

Furthermore, Arial, OCR-B and similar fonts also produce good reading results.

"Text-Genius Plus" additionally allows the training of additional characters for any character set. Expansion of the character set is required to allow recognition of characters which are not included or of those which are deformed as a result of the printing process.

The character sets of the "Text-Genius" license are available as the basis for text recognition with "Text-Genius Plus", meaning that text recognition can be started immediately without further training. "Text-Genius Plus" is particularly suitable for applications with a varying print image and unknown fonts.

Optical identification

Optical character recognition (OCR)

Text-Genius for MV440

Integration

The MV440 text recognition systems can use all communication services that the SIMATIC MV440 basic unit offers:

Usable communication services	
PROFINET IO (FB 79)	Onboard MV440 PROFINET interface.
PROFINET IO (FB 101, Ident profile)	Onboard MV440 PROFINET interface.
PROFINET IO (FB 45, FB 101, Ident profile)	Via MV440 communication module interface, using the RF180C communication module.
Ethernet/IP	Via communication module interface, with communication module RFID 181EIP.
PROFIBUS DP V0/1 (FB 45, Ident profile)	Via MV440 communication module interface, using the ASM 456 communication module.
TCP/IP native	Onboard MV440 PROFINET interface.
RS232 (ASCII)	Onboard MV440 RS232 interface.
SIMATIC S7-1200, S7-300, ET 200pro	Via communication module interface.

The most important types of interface in the automation environment are shown in the overview below.

For further details, refer to the chapter on SIMATIC MV440.

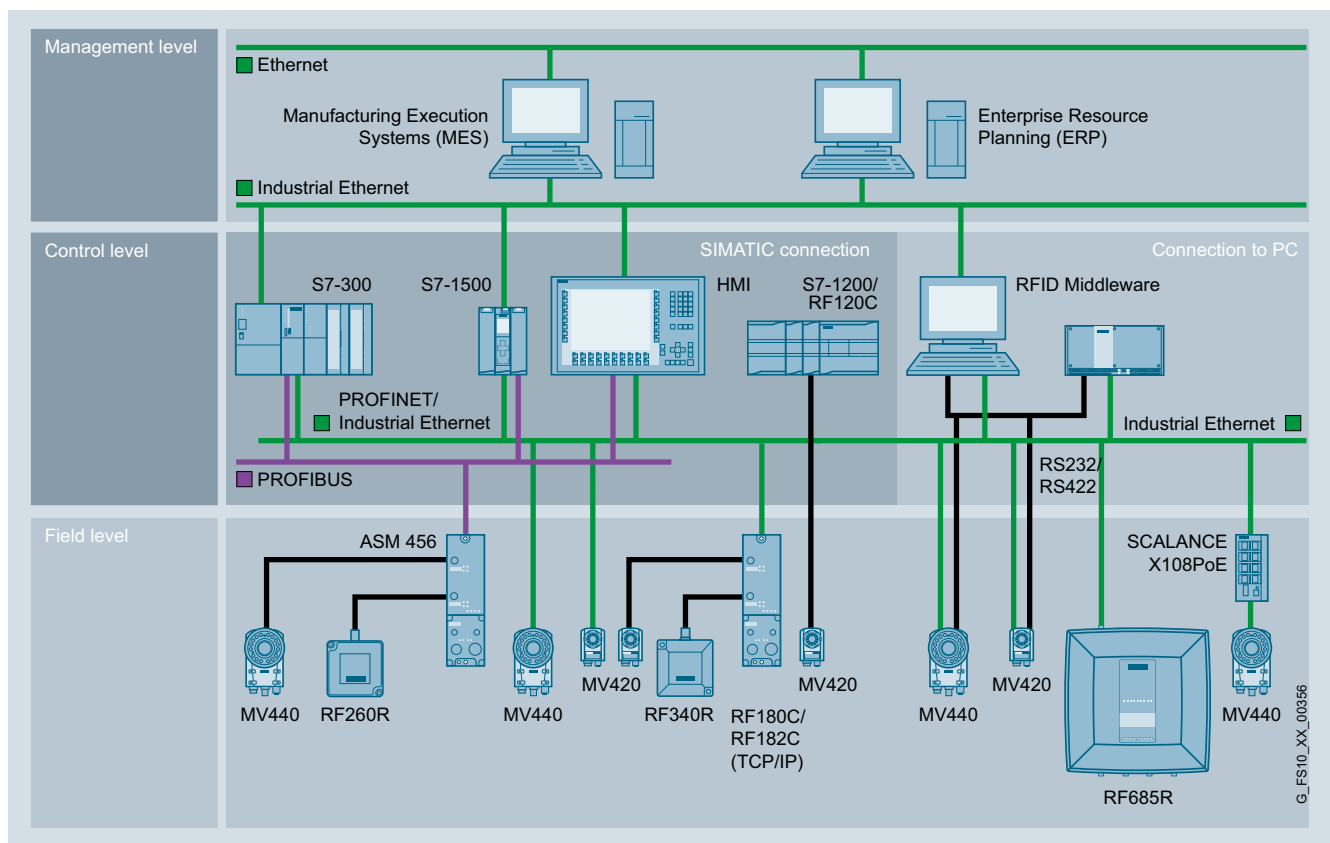

Selection and ordering data

	Article No.
<p>OCR module Text-Genius</p> <p>Software license for reading machine-readable 1D barcodes and 2 D matrix codes, as well as for optical character recognition.</p> <p>The license is supplied on a USB flash drive; executable on optical SIMATIC MV440 readers as of firmware V3.0 (SIMATIC MV440 not included in the scope of delivery).</p>	6GF3400-0SL01
<p>OCR module Text-Genius Plus</p> <p>Software license for machine-readable text recognition (OCR) and for reading 1D barcodes and 2 D matrix codes. Trainable text recognition allows the training of individual characters or even complete character sets. The character sets of Text-Genius are provided as trained, expandable libraries.</p> <p>The license is supplied on a USB flash drive; executable on optical SIMATIC MV440 readers as of firmware V5.0 (SIMATIC MV440 not included in the scope of delivery).</p>	6GF3400-1SL01

Optical identification

Object recognition

Pat-Genius for MV440

Overview

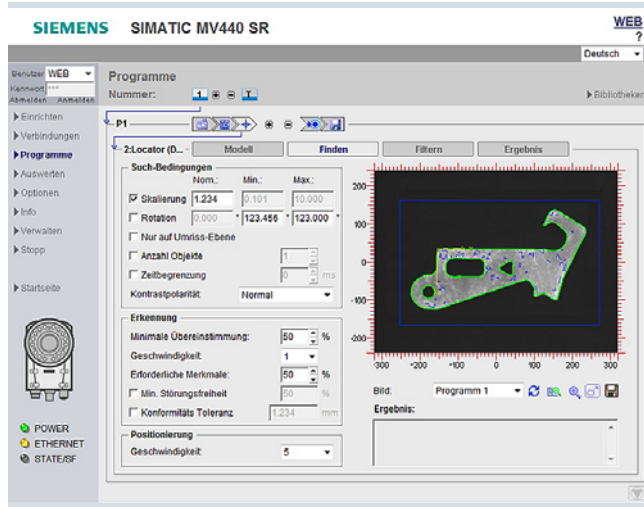

Objekterkennung mit Pat-Genius

With the object recognition license "Pat-Genius", devices of the SIMATIC MV440 family can also be used for checking the specific structures in the image (verification) in addition to reading 1D barcodes and 2D matrix codes.

The license is supplied as a "Single License" on a USB flash drive and can be installed via the SIMATIC Automation License Manager (ALM) on any reader of the SIMATIC MV440 series. The license can be installed on a SIMATIC MV440 as of firmware version 6.0.

Benefits



- Pat-Genius shape recognition contains the following different partial tasks:
 - Object recognition (classification)
 - Position detection (position, rotational position, scaling)
 - Presence check (object recognition and position check with setpoint specification)
 - Completeness check (multiple presence check with setpoint specification)
 - Text recognition (based on the contour of any character or symbol)
- Pat-Genius is easy to operate thanks to its integration in the uniform operating concept for all function packages in the user interface of the MV440 devices
- Pat-Genius can be used together with all other function packages (Text-Genius and Veri-Genius) of the SIMATIC MV440 devices.
- Pat-Genius is available for all resolution versions of the SIMATIC MV440 (640 x 480 pixels, 1 024 x 768 pixels and 1 600 x 1 200 pixels).
- Pat-Genius can be flexibly retrofitted for every device of the SIMATIC MV440 family (via the SIMATIC Automation License Manager). Customer benefit: Cost benefits with stocking spare parts.
- Pat-Genius licenses are transferrable between all SIMATIC MV440 devices without regard for the resolution capacity.
- Pat-Genius supports the proved simple integration of the SIMATIC MV440 devices into the automation environment using a function block (FB 79, FB 45 and FB 101) for the SIMATIC S7-1200, S7-1500, S7-300 and S7-400 controllers.

Application

The functionality of object recognition is basically suitable for applications such as

- Pick-and-place machines
- Quality control in production
- Position detection in infeed systems
- Quantity monitoring in infeed systems and production

Pat-Genius can be used anywhere where ambient conditions permit the use of the optical MV440 reader - for details, see SIMATIC MV440. Standard ring lights and lenses are available for IP67 degree of protection by means of the protective barrel, and for glass-free use in the food and beverages industry. If light sources or lenses are used outside the protective barrel, they must be used in compliance with their specification.

Any host and HMI systems required must be selected for a sector and a specific project. The range of application of the selected test method is defined in the specification of the test method and compliance is essential if universally valid results are to be obtained.

The following sectors and applications are a particular focus for MV440 verification systems:

Automotive industry

For example:

- Testing the manufacturing process: e.g. assembling the body in white, etc.
- Access control for semi-finished products for machining stations in the process: Cylinder heads, etc.
- Monitoring the uniformity of the assembly quality in the manufacturing process

Pharmaceutical industry

For example:

- Checking of warning information on medicines (e.g. Caution poisonous)
- Checking of the correct arrangement of the content and the closing mechanism in the packaging process
- Checking the filling level of packages

Medical equipment

For example:

- Inline quality check and documentation by means of checking completeness and shape consistency

Electronics

For example:

- Inline quality check and documentation by means of checking completeness and shape consistency

Semiconductors

For example:

- Detecting the alignment of components
- Controlling the dimensional accuracy of components

Design

All SIMATIC MV440 stationary optical code reader are basic units under the terms of the "Object recognition" functionality, which is subject to license. The text recognition functionality is enabled by transferring the license key from the supplied USB flash drive to the MV440 reader by means of SIMATIC License Manager.

The functionality is available without a license in demo mode. This function subject to licensing is fully available without performance restrictions in Demo mode. Only output of the results on the communication channels is disrupted. Users can therefore determine in Demo mode whether the functions and performance fulfill their requirements.

Function

The object recognition detects deviations in the current camera image relative to a learned structure using edge structures.

Accordingly, the basic test sequence is as follows:

- Training the object test parameters using one or more good objects
- Testing an object and/or pattern with the features taken from the training
- Testing can be performed on stationary and moving objects
- Checking for a match with the reference provides a good/poor indication after comparison with set-value criteria
- Test results output to three control outputs:
 - OK: Presence of the trained objects and/or pattern recognized by characteristics
 - OK: Level of agreement greater than setpoint
 - ...
 - N_OK: NO presence of trained objects with the specified characteristics
 - N_OK: Deviation from degree of conformity to setpoint
 - ...
- Output of the result information onboard via PROFINET IO, Ethernet, RS232 interface – further interfaces are available via communication modules
- "Stand-alone" mode possible using integrated DI/O
- Remote control via PROFIBUS IO, PROFINET DP (via communication module), DI/O or Ethernet
- Platform-independent, web-based interface (Internet-enabled):
 - Monitoring (live image in read mode)
 - Diagnostics (fault image, log information, ...)
 - System administration (software update, ...)
 - Error analysis for troubleshooting for faulty readings
- Triggering of external ring lights

The overall result and the components of a measurement result can be output after a test via different interfaces, and are then available for further processing on an external system, e.g. for archiving or creating a test report.

Optical identification

Object recognition

Pat-Genius for MV440

Integration

Pat-Genius for SIMATIC MV440 can use all communication services that the SIMATIC MV440 basic unit offers:

Usable communication services	
PROFINET IO (FB 79)	Onboard MV440 PROFINET interface.
PROFINET IO (FB 101, Ident profile)	Onboard MV440 PROFINET interface.
PROFINET IO (FB 45, FB 101, Ident profile)	Via MV440 communication module interface, using the RF180C communication module.
Ethernet/IP	Via communication module interface, with communication module RFID 181EIP.
PROFIBUS DP V0/1 (FB 45, Ident profile)	Via MV440 communication module interface, using the ASM 456 communication module.
TCP/IP native	Onboard MV440 PROFINET interface.
RS232 (ASCII)	Onboard MV440 RS232 interface.
SIMATIC S7-1200, S7-300, ET 200pro	Via communication module interface.

The most important types of interface in the automation environment are shown in the overview below.

For further details, refer to the chapter on SIMATIC MV440.

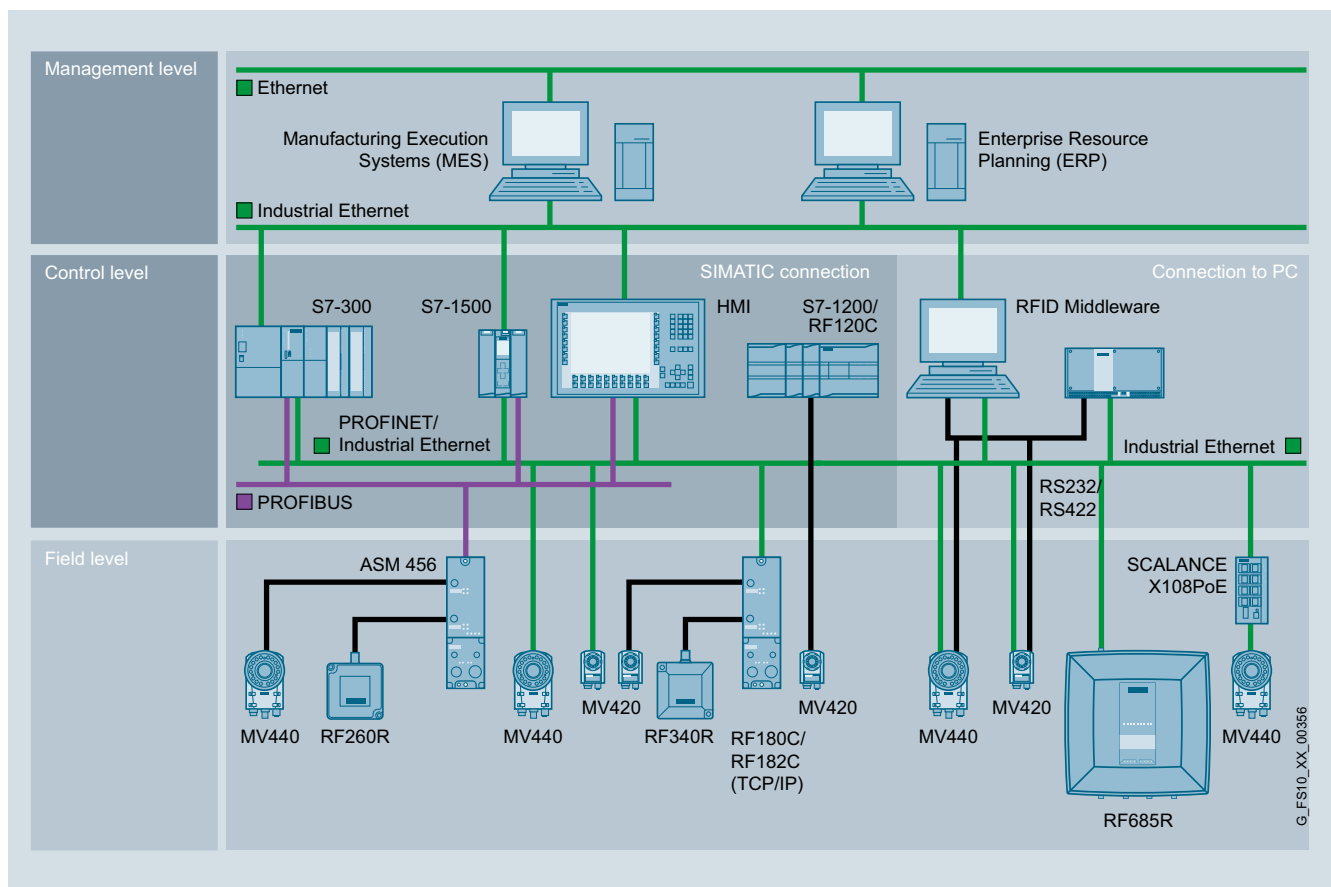

Selection and ordering data

	Article No.
IMATIC "Pat-Genius" license	6GF3400-0SL03
Software license for object recognition in image information on products of the SIMATIC MV440 family.	
The license is supplied on a USB flash drive; usable on all optical SIMATIC MV440 readers as of firmware V6.0 (SIMATIC MV440 not included in the scope of delivery).	

G_FS10_XX_00356

Communication modules, RFID standard cables, SCALANCE network components

5



5/2

Communication modules for RFID systems and optical identification

5/4 ASM 456, RF160C
5/9 RF180C, RF182C, RFID 181EIP
5/16 RF170C
5/19 RF120C
5/22 ASM 475

5/25

RFID standard cables

5/27

SCALANCE network components

5/28 Industrial Ethernet switches
SCALANCE X
5/30 Industrial Wireless LAN SCALANCE W

Communication modules

Introduction

Overview

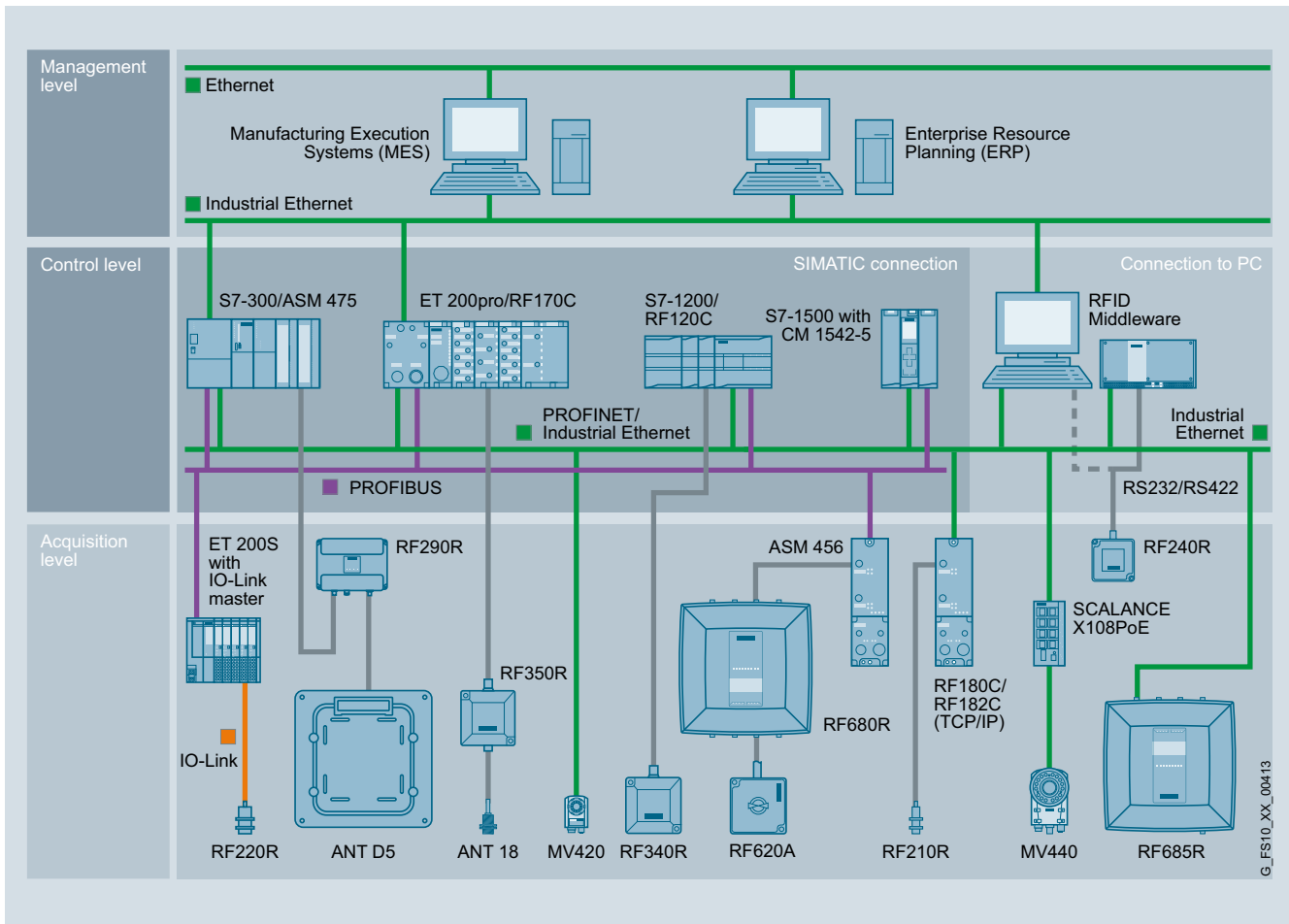

SIMATIC Ident integration graphics

There are various powerful communication modules (ASM) for integrating SIMATIC RFID, SIMATIC MV and MOBY identification systems in SIMATIC, SINUMERIK, SIMOTION, PROFIBUS, PROFINET and Ethernet/IP.

Selection aid for communication modules and software

System	Communication modules without file handler	Identification system	Available software
SIMATIC S7-1200	RF120C	RF200, RF300, RF600, MV400, MOBY D	Ident-Library (Read, Write, Reset_Reader etc.)
SIMATIC S7-300 (direct), S7-300/400, PC with SIMATIC WinAC via ET 200M, SINUMERIK 840D/810D	ASM 475	RF200, RF300, RF600, MV400, MOBY D	FB 45, FB 55
Serial link, to PC, PLC or any other system ¹⁾	Direct via SLG Dx	MOBY D	MOBY D MDWAPI, MOBY API, C library incl. drivers for Windows XP/7
	Direct via RF2xxR, RF3xxR (RS422 / RS232) reader	RF200, RF300	
PROFIBUS DP (SIMATIC S7, PC, any other system ¹⁾)	RF160C	RF200, RF300, RF600, MOBY D	FC 44 for S7-300/400, PC with SIMATIC WinAC
SIMATIC S7, PC with SIMATIC WinAC, via ET 200pro	RF170C	RF200, RF300, RF600, MV400, MOBY D	FB 45, FB 55 (S7-300/400 only), Ident profile, Ident Library (for all S7; Read, Write, Reset_Reader etc.)
PROFIBUS DP-V1 (SIMATIC S7, SIMOTION SCOUT, PC, any other system ¹⁾)	ASM 456	RF200, RF300, RF600, MV400, MOBY D	FB 45, FB 55 (S7-300/400 only), FB101/116/132, Ident profile, Ident Library (for all S7; Read, Write, Reset_Reader etc.)
PROFINET IO	RF180C	RF200, RF300, RF600, MV400, MOBY D	FB 45, FB 55 (S7-300/400 only), FB 101/116/132, Ident profile, Ident Library (for all S7; Read, Write, Reset_Reader etc.)
Ethernet TCP/IP	RF182C	RF200, RF300, RF600, MOBY D	XML application examples
Ethernet/IP	RFID 181EIP	RF200, RF300, RF600, MV400, MOBY D	Programming via implicit/explicit messages

System	Communication modules without file handler	Identification system	Available software
SIMATIC S7, PC, any other system, SIMOTION SCOUT	ASM 456	RF300	FC 56, FB 101/116/132
Ethernet/IP	RFID 181EIP	RF300	Programming via implicit/explicit messages

Function

Corresponding software blocks (FB, FC, libraries, examples) ensure simple and quick integration into the application.

1 or 2 readers can be connected to a communication module (CM, ASM) with a maximum cable length of 1 000 m (depending on the CM, ASM, reader, etc.). Corresponding procedures guarantee a very high reliability of data transmission.

For the serial connection of SIMATIC RFID to any system (PC, PLC, etc.) the readers can be directly connected via an RS232 port.

Note regarding FC 45/55

The FC 45/55 can still be used in existing applications. For new applications, however, the FB 45/55 blocks or the Ident profile are recommended because only these blocks contain all functions.

Notes regarding software and licensing

No software or documentation is supplied when purchasing a communication module (CM) or reader. The DVD "RFID Systems Software & Documentation" contains all the FBs/FCs available for SIMATIC, C libraries for Windows XP/7 operating systems, demo programs, etc. and must be ordered separately. In addition, the DVD contains the complete RFID documentation in all available languages in PDF format.

The purchase of a CM or reader includes a payment for use of the software, including documentation, on the DVD "RFID Systems Software & Documentation". The purchaser acquires the right to make copies (copy license), insofar as they are required as part of the plant project.

The General License Conditions, included on the respective DVD, shall apply.

Integration

SIMATIC Ident Configuration Guide

Here is a compact configuration tool for setting up RFID systems:

<http://support.automation.siemens.com/WW/view/en/67384964>

¹⁾ The programming interface is described for connecting to any system.

Communication modules

ASM 456, SIMATIC RF160C

Overview

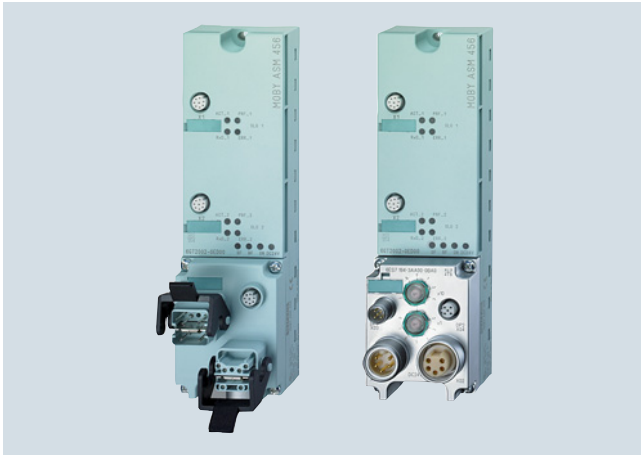

The low-cost communications modules ASM 456 and SIMATIC RF160C are stand-alone PROFIBUS DP slaves for the operation of MOBY D, SIMATIC RF200 / RF300 / RF600 RFID systems as well as the MV400 optical reader devices via PROFIBUS DP on:

- SIMATIC S7 (including FB/FC software)
- SINUMERIK
- PC, IPC, non-Siemens PLC
- SIMOTION (with integrated software library)

Thanks to their high degree of protection and ruggedness, they are particularly suitable for machine-level use. The modular structure with different PROFIBUS connection systems allows them to be used in all applications. The uniform plug-in connection system ensures rapid commissioning.

Benefits

get Designed for Industry

- Two parallel MOBY channels ensure real-time mode at dynamic read points.
- Modular design with different bus interfacing possibilities ensures universal implementation.
- Reader connection using an 8-pin M12 connector for quick mounting of all components.
- High-performance hardware ensures fast data exchange with the reader. Consequently, data is available for the application even faster.
- Simple firmware downloading via the TIA Portal in the case of function expansions and error rectification ensures high availability of the identification system.
- The parameterizable identification-system-specific PROFIBUS diagnostics facilitate start-up and troubleshooting.
- A wide selection of pre-assembled PROFIBUS connecting cables can be ordered for the communication modules. This saves time and money during installation and assures better quality.

Application

The ASM 456 and SIMATIC RF160C communication modules have been specifically designed for a wide range of applications in industrial automation and logistics. Thanks to the high IP67 degree of protection, the ASM 456 and RF160C can be installed in the process without a control cabinet.

Main application areas for ASM 456 and RF160C:

- Mechanical engineering, automation systems, conveyor systems
- Ancillary assembly lines in the automobile industry/suppliers
- Small assembly lines
- Production, packaging, textile, plastics and printing machines
SIMOTION

Design

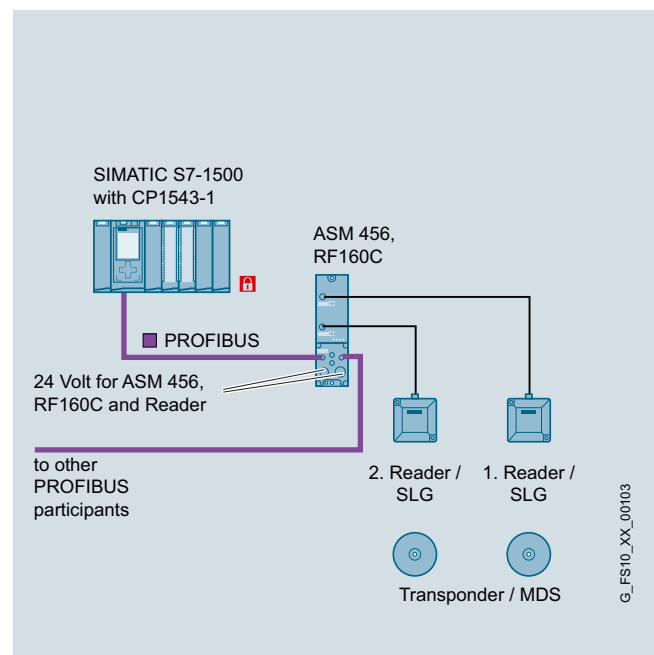

Configuration of ASM 456 and SIMATIC RF160C

Function

The ASM 456 and the RF160C comprise a basic module and a connection block that must be ordered separately. When connecting PROFIBUS, the customer can choose between ECOFAST connections and M12, 7/8" connections.

A pre-assembled reader cable, available in lengths from 2 m to 50 m, is used to connect one or two readers/SLGs to the communication module. The cable can also be assembled by the customer as required.

The PROFIBUS DP procedure according to EN 50170 Vol. 2 PROFIBUS for communication between the communication module and SIMATIC S7 (or any PROFIBUS master) and the MOBY-specific procedures for communication between ASM and reader are implemented on the communication modules.

The data in the transponder can be accessed as follows:

- Direct addressing via absolute addresses
- Conveniently via the MOBY file handler (RF300 only) using file names (for ASM 456 only)

On the PROFIBUS DP, the communication module occupies a node address on the bus that is set on the connection block. The communication module is integrated into the hardware configuration by means of a device master (GSD) file. Then the communication module can be configured by means of the software tool HW_Config of the SIMATIC Manager or another PROFIBUS tool.

Error messages and operating states (transponder in the field, transmission active, etc.) are indicated additionally by means of LEDs and simplify commissioning and service.

ASM 456 and RF160C have two reader interfaces which also provide the readers with power. In the communication module, the power supply of the readers has an electronic fuse. If the reader requires more than 400 mA current (e.g. RF290R), only one reader can be operated on the communication module to avoid exceeding the maximum permissible current.

ASM 456

The ASM directly accesses the data in the transponder or the data matrix code via absolute addresses (FB/FC 45, FB/FC 55) or more conveniently using the MOBY file handler (FC 56) and file names. The communication module is operated in non-cyclic mode over PROFIBUS DP V1. Consequently, a very large amount of data can be transferred to/from the communication module without overloading the PROFIBUS cycle. This has advantages when transferring large volumes of data. In addition, the communication module can process concatenated transponder commands very quickly in this mode.

Function blocks FB 101/116/132 or the Ident Library in the SIMATIC S7 are available for the "RFID standard profile" mode. The Ident Library is integrated in the TIA Portal and offers functions that are very easy to parameterize. The communication module is also integrated in SIMOTION by means of the "RFID standard profile" mode.

SIMATIC RF160C

The data in the transponder is accessed via absolute addresses. The FC 44 function block is available for SIMATIC S7 for this purpose. The RF160C is operated in cyclic mode over PROFIBUS DP-V0. This ensures a deterministic response in data communication in every case. Where there are large volumes of data, together with large-scale bus configurations, the data throughput should be tested with a tool which is provided on the DVD "RFID Systems, Software and Documentation". The programming interface to RF160C is extremely easy to use and can be programmed efficiently in any controller. The RF160C is therefore particularly suitable for use with non-Siemens controllers and older PROFIBUS masters.

Technical specifications







	6GT2002-0ED00	6GT2002-0EF00
Article number	6GT2002-0ED00	6GT2002-0EF00
Product type designation	ASM 456 communication module	RF160C communication module
Suitability for operation	PROFIBUS network according to DP-V1 together with RF200/300/600, MV400, MOBY D/E/I/U	PROFIBUS network according to DP-V0 together with RF200/300/600, MOBY D/U
Transmission rate		
Transfer rate with PROFIBUS	9.6 kbit/s ... 12 Mbit/s	9.6 kbit/s ... 12 Mbit/s
Transfer rate at the point-to-point connection serial maximum	115.2 kbit/s	115.2 kbit/s
Interfaces		
Design of the interface for point-to-point connection	RS422	RS422
Number of readers connectable	2	2
Type of electrical connection		
• of the PROFIBUS interface	(according to the connection block)	(according to the connection block)
• for supply voltage	(according to the connection block)	(according to the connection block)
Design of the interface to the reader for communication	M12, 8-pin	M12, 8-pin
Mechanical data		
Material	Thermoplastic (Valox 467, fiberglass reinforced)	Thermoplastic (Valox 467, fiberglass reinforced)
Color	IP Basic 714	IP Basic 714
Tightening torque of the screw for securing the equipment maximum	3 Nm	3 Nm

Communication modules

ASM 456, SIMATIC RF160C

Article number	6GT2002-0ED00	6GT2002-0EF00
Product type designation	ASM 456 communication module	RF160C communication module
Supply voltage, current consumption, power loss		
Supply voltage		
• at DC Rated value	24 V	24 V
• at DC	20 ... 30 V	20 ... 30 V
Consumed current at DC at 24 V		
• without connected devices typical	0.08 A	0.08 A
• with connected devices maximum	0.85 A	0.85 A
Permitted ambient conditions		
Ambient temperature		
• during operation	0 ... 55 °C	0 ... 55 °C
• during storage	-40 ... +70 °C	-40 ... +70 °C
• during transport	-40 ... +70 °C	-40 ... +70 °C
Protection class IP	IP67	IP67
Shock resistance	According to IEC 61131-2	According to IEC 61131-2
Shock acceleration	300 m/s ²	300 m/s ²
Vibrational acceleration	100 m/s ²	100 m/s ²
Design, dimensions and weight		
Width	60 mm	60 mm
Height	30 mm	30 mm
Depth	210 mm	210 mm
Net weight	0.21 kg	0.21 kg
Mounting type	2 x M5 screws	2 x M5 screws
Cable length for RS422 interface maximum	1 000 m	1 000 m
Product properties, functions, components general		
Display version	4 LEDs per reader connection, 4 LEDs for device status	4 LEDs per reader connection, 4 LEDs for device status
Product function transponder file handler can be addressed	Yes	No
Protocol is supported		
• PROFIBUS DP-V0 protocol	No	Yes
• PROFIBUS DP-V1 protocol	Yes	No
Type of parameterization	GSD	GSD
Type of programming	FB 45, FB 55, FC 56, Ident profile (PIB), (FC 45/55 with limited functionality)	FC 44
Type of computer-mediated communication	acyclic communication	Cyclic communication
Standards, specifications, approvals		
Certificate of suitability	CE, FCC, cULus	CE, FCC, cULus
MTBF	122 y	122 y
Accessories		
Accessories	Connection block for ECOFAST system or M12, 7/8"	Connection block for ECOFAST system or M12, 7/8"

Selection and ordering data







	Article No.		Article No.
ASM 456 communication module For connecting 2 readers to PROFIBUS DP-V1.	6GT2002-0ED00	Accessories M12, 7/8" connection	
RF160C communication module For connecting 2 readers to PROFIBUS DP-V0.	6GT2002-0EF00	M12 connection block, 7/8"	6ES7194-3AA00-0BA0
Accessories ECOFAST connection			
ECOFAST connection block	6ES7194-3AA00-0AA0	M12 terminating resistor for PROFIBUS Pack with 5 units, minimum ordering quantity 1 pack.	6GK1905-0EC00
			
PROFIBUS ECOFAST HYBRID plug 180 • With male insert (5-pack) • With female insert (5-pack)	6GK1905-0CA00 6GK1905-0CB00	PROFIBUS M12 connecting cable Pre-assembled, with 5-pin M12 connector and socket, max. length 100 m.	
PROFIBUS ECOFAST termination plug With terminating resistors.	6GK1905-0DA10		
PROFIBUS ECOFAST hybrid cable - Cu Trailing-type cable (PUR casing) with two shielded copper cables for PROFIBUS DP and four copper cores of 1.5 mm ² each. • Sold by the meter max. length 1 000 m; minimum order quantity 20 m.	6XV1830-7AH10	0.3 m 0.5 m 1 m 1.5 m 2 m 3 m 5 m 10 m 15 m	6XV1830-3DE30 6XV1830-3DE50 6XV1830-3DH10 6XV1830-3DH15 6XV1830-3DH20 6XV1830-3DH30 6XV1830-3DH50 6XV1830-3DN10 6XV1830-3DN15
		7/8" plug-in cable Prefabricated, with 5-pin 7/8" connector and socket, max. length 50 m.	
• Prefabricated with ECOFAST male and female connectors, fixed length:			
0.5 m	6XV1830-7BH05	0.3 m	6XV1822-5BE30
1 m	6XV1830-7BH10	0.5 m	6XV1822-5BE50
1.5 m	6XV1830-7BH15	1 m	6XV1822-5BH10
3 m	6XV1830-7BH30	1.5 m	6XV1822-5BH15
5 m	6XV1830-7BH50	2 m	6XV1822-5BH20
10 m	6XV1830-7BN10	3 m	6XV1822-5BH30
15 m	6XV1830-7BN15	5 m	6XV1822-5BH50
20 m	6XV1830-7BN20	10 m	6XV1822-5BN10
25 m	6XV1830-7BN25	15 m	6XV1822-5BN15
30 m	6XV1830-7BN30		
35 m	6XV1830-7BN35		
40 m	6XV1830-7BN40		
45 m	6XV1830-7BN45		
50 m	6XV1830-7BN50		

Other special lengths with 90° or 120° cable connection, see

<http://support.automation.siemens.com/WW/view/en/26999294>

Communication modules

ASM 456, SIMATIC RF160C

	Article No.		Article No.
PROFIBUS FC Standard Cable Standard type with special design for quick mounting, 2-core, shielded, sold by the meter; maximum ordering quantity unit 1 000 m, minimum ordering quantity 20 m. 	6XV1830-0EH10	RFID accessories MOBY D reader cable PUR material, CMG approval, suitable for cable carriers, 2 m. 	6GT2691-4FH20
PROFIBUS M12 cable connector Pack with 5 units, minimum ordering quantity 1 pack. <ul style="list-style-type: none"> • With male insert • With female insert 	6GK1905-0EA00 6GK1905-0EB00	Reader cable for SIMATIC RF200 / RF300 / RF600 / MV440 Or extension cable MOBY D and SIMATIC RF200 / RF300 / RF600 / MV400, PUR material, CMG approval, suitable for cable carriers 	
7/8" cable connector for voltage Pack with 5 units, minimum ordering quantity 1 pack. 	6GK1905-0FA00 6GK1905-0FB00	2 m, straight connector 5 m, straight connector 10 m, straight connector 20 m, straight connector 50 m, straight connector 2 m, plug angled at reade 5 m, plug angled at reade 10 m, plug angled at reade	6GT2891-4FH20 6GT2891-4FH50 6GT2891-4FN10 6GT2891-4FN20 6GT2891-4FN50 6GT2891-4JH20 6GT2891-4JH50 6GT2891-4JN10
Sealing caps 7/8" For unused 24 V cable extension, pack of 10, minimum ordering quantity 1 pack. 	6ES7194-3JA00-0AA0	Sealing caps M12 for unused reader connections Minimum ordering quantity 10 units.	3RX9802-0AA00
Power line 5-core, 5 x 1.5 mm ² , trailing type; sold by the meter; maximum ordering quantity 1 000 m, minimum ordering quantity 20 m. 	6XV1830-8AH10	DVD "RFID Systems Software & Documentation"	6GT2080-2AA20
General accessories Stainless steel screws for connection blocks Optional screws made of V4A steel for securing the connection blocks on the basic module. For use in wet areas. Pack with 40 units is sufficient for 10 connection blocks. 	6GT2090-0VB00		

Dimensional drawings

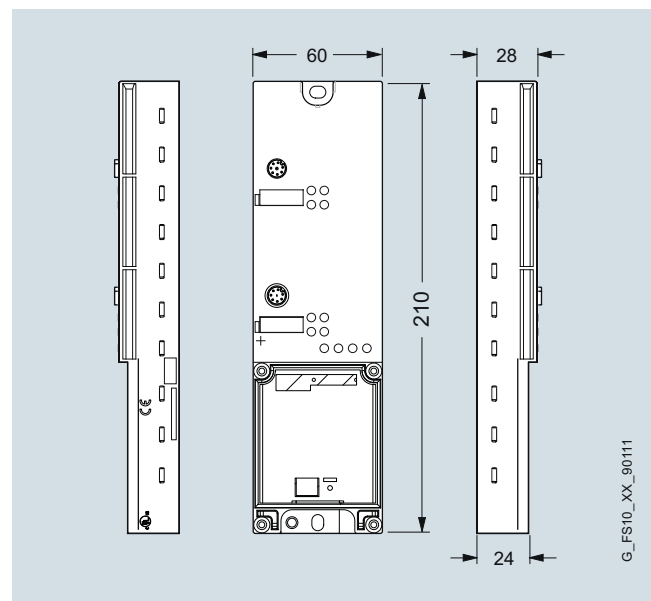

ASM 456 and SIMATIC RF160C communication modules

Overview



6GT2002-OJD00



6GT2002-OJD10



6GT2002-OJD20

SIMATIC RF180C/RF182C and RFID 181EIP are communication modules for direct connection of SIMATIC identification systems to PROFINET IO/Ethernet and Ethernet/IP. The readers (SLG) of the RFID systems MOBY D, SIMATIC RF200 / RF300 / RF600 as well as the MV400 optical reader devices (RF180C and RFID 181EIP only) can be operated on the communication modules.

Due to the high degree of protection and ruggedness, SIMATIC RF180C / RF182C and RFID 181EIP are particularly suitable for machine level use. The uniform plug-in connection system ensures rapid commissioning.

Benefits

g e t Designed for Industry

- Two parallel reader channels ensure real-time mode at dynamic read points.
- Reader connection using an 8-pin M12 connector for fast installation of all components.
- Different connection systems to suit any application:
 - M12, 7/8", the well-proven round connectors.
 - Push-pull connectors for quick assembly with RJ45 data connectors and 24 V connectors.
- Easy changeover from PROFIBUS applications to PROFINET with SIMATIC RF180C thanks to software compatibility.
- The integrated switch allows several PROFINET/Ethernet modules to be installed in a star or bus topology. Each application can then be set up quickly and inexpensively.
- Powerful hardware ensures rapid data communication with the reader (SLG). Consequently, data is available for the application even faster.
- Simple firmware downloading in the case of function expansions and error rectification ensures high availability of the identification system.
- Adjustable and parameterizable identification-system-specific diagnostics facilitate easy commissioning and troubleshooting.
- A broad selection of pre-assembled connecting cables can be ordered for connecting PROFINET/Ethernet and readers to SIMATIC RF180C/RF182C. This saves time and money during installation and assures better quality.

Application

The Ethernet-based communication modules have been specially designed for a wide range of applications in industrial automation and logistics. Due to their high IP67 degree of protection, SIMATIC RF180C/RF182C and RFID 181EIP can be installed in the process outside the control cabinet.

Main applications for SIMATIC RF180C/RF182C and RFID 181EIP:

- Mechanical engineering, automation systems, conveyor systems
- Ancillary assembly lines in the automotive industry / suppliers
- Small assembly lines

Communication modules

SIMATIC RF180C / RF182C / RFID 181EIP

Design

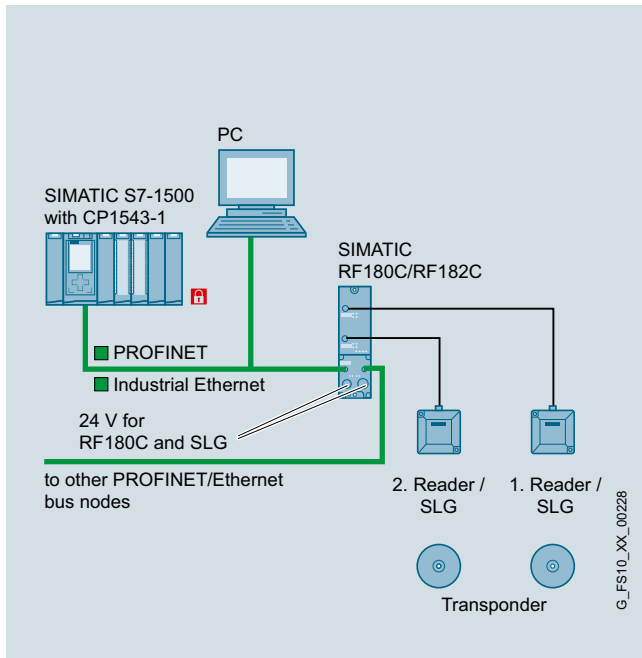

The data in the transponder can in principle be accessed by direct addressing using absolute addresses.

Error messages and operating states (transponder in the field, transmission, etc.) are indicated additionally by means of LEDs and simplify commissioning and service.

The SIMATIC RF180C/RF182C and RFID 181EIP communication modules have two reader interfaces from which the readers are also supplied with voltage. In the communication module, the power supply of the readers has an electronic fuse. The maximum permissible current per communication module for the readers is 1 A. It is of no importance here whether the current is drawn by 1 or 2 readers.

SIMATIC RF180C

The SIMATIC RF180C is designed for use in PROFINET networks. SIMATIC RF180C is integrated in SIMATIC STEP 7 via the GSDML file. The SIMATIC RF180C can then be configured using the device manager of the TIA Portal or another PROFINET tool.

The application accesses the transponder via the FB 45 or via blocks from the Ident Library. The transponder is addressed using absolute addresses. For large volumes of data and complex tag operations, the FB 45 can process chained commands. The Ident Library is already integrated in the TIA Portal and offers functions that are very easy to parameterize.

Data is exchanged between SIMATIC RF180C and the application by means of acyclic data records. This ensures that large quantities of data can be transferred from/to SIMATIC RF180C without loading the bus cycle.

Using the "RFID standard profile" setting, the RF180C can be operated directly in a SIMOTION.

SIMATIC RF182C

The SIMATIC RF182C is designed for use in Ethernet networks based on TCP/IP. The IP address of the SIMATIC RF182C is set using the "Primary Setup Tool". The RF182C is then ready for operation. This tool can be downloaded from

<http://support.automation.siemens.com/WW/view/en/19440762>

Communication with the SIMATIC RF182C is implemented using XML commands. XML commands have a very simple structure. This makes programming of the RF182C under any operating system very easy. The simple command set of the RF182C can also be programmed easily in any Ethernet-capable controller.

RFID 181EIP

The communication module RFID 181EIP is designed for use in Ethernet/IP networks. A DHCP server automatically assigns an IP address to the RFID 181EIP. Alternatively, the user can assign issue static IP addresses on the DHCP server. The standard tool for assigning IP addresses is called the BOOTP/DHCP server and is included in the RSLinx software package.

The RFID 181EIP communicates with the reader by means of implicit and explicit messages. Commands and results are transferred with explicit messages. The user sets up the commands directly in the application program. Application examples are available to make getting started easier.

Function

The SIMATIC RF180C/RF182C and RFID 181EIP communication modules consist of a basic module and a connection block that must be ordered separately.

The connection block is available in three versions:

- M12, 7/8" (5-pole): PROFINET/Ethernet is connected by means of an M12 connector, the power supply is connected by means of a 5-pole 7/8" connector. There are 2 connections each for PROFINET/Ethernet as well as for the power supply. This ensures that the SIMATIC RF180C/RF182C can be connected to additional bus nodes without the need for external distributors. The removable connection block allows a base module to be replaced without interrupting the supply voltage to other bus stations.
- Push-pull connector (according to IEC 61918): PROFINET/Ethernet and the power supply are connected by means of a push-pull connector. There are 2 connections each for PROFINET/Ethernet as well as for the power supply. This ensures that SIMATIC RF180C/RF182C can be connected to additional bus nodes without the need for external distributors. The supply voltage connectors can conduct currents of up to 12 A (1L+ and 2L+). The removable connection block allows a base module to be replaced without interrupting the supply voltage to other bus stations.
- M12, 7/8" (4-pole; not recommended for RF180C): Ethernet is connected by means of an M12 connector, the power supply is connected by means of a 4-pole 7/8" connector. There are 2 connections for Ethernet and one connection is available for the power supply. This connection block can be used in applications where the 5-pole 7/8" connector is already being used for other functions and therefore cannot be used for the power supply.

A pre-assembled reader cable, available in lengths from 2 m to 50 m, is used to connect one or two readers to the communication module. The cable can also be assembled by the customer as required.

Technical specifications





Article number	6GT2002-0JD00	6GT2002-0JD10	6GT2002-0JD20
Product type designation	RF180C communication module	RF182C communication module	RFID 181EIP communication module
Suitability for operation	PROFINET network together with RF200/300/600, MV400, MOBY D/E/I/U	Industrial Ethernet network together with RF200/300/600, MOBY D/U	Ethernet/IP network together with RF200/300/600, MV400, MOBY D/E/I/U
Transmission rate			
Transfer rate for Industrial Ethernet	10 ... 100 Mbit/s	10 ... 100 Mbit/s	10 ... 100 Mbit/s
Transfer rate at the point-to-point connection serial maximum	115.2 kbit/s	115.2 kbit/s	115.2 kbit/s
Interfaces			
Design of the interface for point-to-point connection	RS422	RS422	RS422
Number of readers connectable	2	2	2
Type of electrical connection			
• of Industrial Ethernet interface	(according to the connection block)	(according to the connection block)	(according to the connection block)
• for supply voltage	(according to the connection block)	(according to the connection block)	(according to the connection block)
Design of the interface to the reader for communication	M12, 8-pin	M12, 8-pin	M12, 8-pin
Mechanical data			
Material	Thermoplastic (Valox 467, fiberglass reinforced)	Thermoplastic (Valox 467, fiberglass reinforced)	Thermoplastic (Valox 467, fiberglass reinforced)
Color	IP Basic 714	IP Basic 714	IP Basic 714
Tightening torque of the screw for securing the equipment maximum	3 Nm	3 Nm	3 Nm
Supply voltage, current consumption, power loss			
Supply voltage			
• at DC Rated value	24 V	24 V	24 V
• at DC	20 ... 30 V	20 ... 30 V	20 ... 30 V
Consumed current at DC at 24 V			
• without connected devices typical	0.1 A	0.1 A	0.1 A
• with connected devices maximum	1.1 A	1.1 A	1.1 A
Permitted ambient conditions			
Ambient temperature			
• during operation	0 ... 60 °C	0 ... 60 °C	0 ... 60 °C
• during storage	-40 ... +70 °C	-40 ... +70 °C	-40 ... +70 °C
• during transport	-40 ... +70 °C	-40 ... +70 °C	-40 ... +70 °C
Protection class IP	IP67	IP67	IP67
Shock resistance	According to IEC 61131-2	According to IEC 61131-2	According to IEC 61131-2
Shock acceleration	300 m/s ²	300 m/s ²	300 m/s ²
Vibrational acceleration	100 m/s ²	100 m/s ²	100 m/s ²
Design, dimensions and weight			
Width	60 mm	60 mm	60 mm
Height	30 mm	30 mm	30 mm
Depth	210 mm	210 mm	210 mm
Net weight	0.21 kg	0.21 kg	0.21 kg
Mounting type	2 x M5 screws	2 x M5 screws	2 x M5 screws
Cable length for RS422 interface maximum	1 000 m	1 000 m	1 000 m

Communication modules

SIMATIC RF180C / RF182C / RFID 181EIP









Article number	6GT2002-0JD00	6GT2002-0JD10	6GT2002-0JD20
Product type designation	RF180C communication module	RF182C communication module	RFID 181EIP communication module
Product properties, functions, components general			
Display version	4 LEDs per reader connection, 4 LEDs for device status	4 LEDs per reader connection, 4 LEDs for device status	4 LEDs per reader connection, 4 LEDs for device status
Protocol is supported Media Redundancy Protocol (MRP)	No	No	No
Product function transponder file handler can be addressed	Yes	No	Yes
Protocol is supported			
• LLDP	Yes	No	No
• PROFINET IO protocol	Yes	No	No
• TCP/IP	No	Yes	No
• EtherNet/IP protocol	No	No	Yes
Type of parameterization	GSDML	XML	EDS file
Type of programming	FB 45, FB 55, Ident profile (PIB)	XML commands	Data records via implicit/explicit messages
Type of computer-mediated communication	acyclic communication	XML	Implicit/explicit messaging
Standards, specifications, approvals			
Certificate of suitability	CE, FCC, cULus, PNO: Conformance Class B	CE, FCC, cULus	CE, FCC, cULus
MTBF	121 y	121 y	121 y
Accessories			
Accessories	Connection block M12 d-coded, 7/8" 5-pin or push-pull	Connection block M12 d-coded, 7/8" 5-pin or push-pull or M12 d-coded, 7/8" 4-pin	Connection block M12 d-coded, 7/8" 5-pin or push-pull or M12 d-coded, 7/8" 4-pin



Selection and ordering data

	Article No.		Article No.
SIMATIC RF180C communication module For PROFINET, for connecting 2 readers, without a connection block.	6GT2002-0JD00		
SIMATIC RF182C communication module For Ethernet, for connecting 2 readers, without a connection block.	6GT2002-0JD10		
RFID 181EIP communication module For Ethernet/IP, for connecting 2 readers, without a connection block.	6GT2002-0JD20		
Connection block For SIMATIC RF180C/RF182C, M12 d-coded, 7/8" (5-pole). 	6GT2002-1JD00	Accessories for network connection M12, 7/8" (5-pole) IE connecting cable M12-180/M12-180 Pre-assembled IE FC TP trailing cable GP 2x2 (PROFINET Type C), with two 4-pin M12 plugs (D-coded), maximum length 85 m, IP65/IP67 degree of protection. 	
		0.3 m	6XV1870-8AE30
		0.5 m	6XV1870-8AE50
		1 m	6XV1870-8AH10
		1.5 m	6XV1870-8AH15
		2 m	6XV1870-8AH20
		3 m	6XV1870-8AH30
		5 m	6XV1870-8AH50
		10 m	6XV1870-8AN10
		15 m	6XV1870-8AN15
Connection block For SIMATIC RF180C/RF182C, push-pull RJ45. 	6GT2002-2JD00	7/8" connecting cable to power supply Pre-assembled with two 5-pin 7/8" male and female connectors. 	
		0.3 m	6XV1822-5BE30
		0.5 m	6XV1822-5BE50
		1 m	6XV1822-5BH10
		1.5 m	6XV1822-5BH15
		2 m	6XV1822-5BH20
		3 m	6XV1822-5BH30
		5 m	6XV1822-5BH50
		10 m	6XV1822-5BN10
		15 m	6XV1822-5BN15
Connection block For SIMATIC RF182C, RFID 181EIP, M12 d-coded, 7/8" (4-pole). 	6GT2002-4JD00	Other special lengths with 90° or 120° cable connection, see http://support.automation.siemens.com/WW/view/en/26999294	

Communication modules

SIMATIC RF180C / RF182C / RFID 181EIP

	Article No.		Article No.
PROFINET M12 plug-in connectors Rugged metal housing; axial cable outlet; D-coded. 	6GK1901-0DB20-6AA0	Accessories for push-pull RJ45 network connection	
7/8" cable connector, for voltage Pack with 5 units, minimum ordering quantity 1 pack. 		Push-pull cable connector for 1L+/2L+ Unassembled.	6GK1907-0AB10-6AA0
<ul style="list-style-type: none"> • With male insert • With female insert 	6GK1905-0FA00 6GK1905-0FB00	Push-pull cable connector for RJ45 Unassembled.	6GK1901-1BB10-6AA0
IE M12 control cabinet bushing For conversion from M12 (D-coded) to RJ45, pack with 5 units, minimum ordering quantity 1 pack. 	6GK1901-0DM20-2AA5	Cover caps for push-pull female connectors (1L+/2L+), pack of 5.	6ES7194-4JA50-0AA0
IE Connecting Cable M12-180/IE FC RJ45 Plug 145 Prefabricated IE FC TP trailing cable GP 2 x 2 (PROFINET type C) with M12 plug (D-coded) and IE FC RJ45 plug, IP65/IP67 degree of protection. 		Cover caps for push-pull female connectors RJ45, pack of 5.	6ES7194-4JD50-0AA0
2 m 3 m 5 m 10 m 15 m	6XV1871-5TH20 6XV1871-5TH30 6XV1871-5TH50 6XV1871-5TN10 6XV1871-5TN15	Accessories for network connection M12, 7/8" (4-pole)	
IE FC RJ45 PLUG 180 RJ45 plug With rugged metal housing and FC connection system, straight cable outlet. 	6GK1901-1BB10-2AA0	Network wiring with M12 Accessories, as for M12, 7/8" (5-pole)	
Sealing caps 7/8" Pack with 10 units, minimum ordering quantity 1 pack. 	6ES7194-3JA00-0AA0	Power supply with 7/8" (4-pole) No cables and connectors from Siemens	
		Accessories for PROFINET bus components	
		SCALANCE XB205-3 Industrial Ethernet Switch With five 10/100 Mbps RJ45 ports and three fiber-optic cable ports (MM FO SC). Description see page 5/28. 	6GK5205-3BD00-2AB2
		SCALANCE X204IRT PRO Industrial Ethernet switch with four 10/100 Mbps RJ45 push-pull ports. Description see page 5/27. 	6GK5204-0JA00-2BA6
		IE FC TP standard cable GP 2x2 4-core, shielded TP installation cable for connection to IE, FC outlet RJ45/IE FC RJ45 plug, PROFINET-compatible, with UL approval, sold by the meter, max. delivery unit 1 000 m, minimum ordering quantity 20 m 	6XV1840-2AH10

	Article No.
<p>Power line</p> <p>5-core, 5 x 1.5 mm², trailing type, sold by the meter, minimum ordering quantity 20 m, maximum ordering quantity 1 000 m.</p> 	6XV1830-8AH10
General accessories	
<p>Stainless steel screws for connection blocks</p> <p>Optional screws made of V4A steel for securing the connection blocks on the basic module. For use in wet areas. Pack with 40 units is sufficient for 10 connection blocks.</p> 	6GT2090-0VB00
RFID accessories	
<p>MOBY D reader cable</p> <p>PUR material, CMG approval, suitable for cable carriers, 2 m.</p> 	6GT2691-4FH20
<p>Reader cable for SIMATIC RF200 / RF300 / RF600 / MV440</p> <p>Or extension cable MOBY D and SIMATIC RF200 / RF300 / RF600 / MV400, PUR material, CMG approved, suitable for cable carriers</p> 	
2 m, straight connector	6GT2891-4FH20
5 m, straight connector	6GT2891-4FH50
10 m, straight connector	6GT2891-4FN10
20 m, straight connectore	6GT2891-4FN20
50 m, straight connector	6GT2891-4FN50
2 m, plug angled at reader	6GT2891-4JH20
5 m, plug angled at reader	6GT2891-4JH50
10 m, plug angled at reader	6GT2891-4JN10
<p>Sealing caps M12 for unused reader connections</p> <p>Minimum ordering quantity 10 units.</p>	3RX9802-0AA00
<p>DVD „RFID Systems Software & Documentation“</p>	6GT2080-2AA20

Dimensional drawings

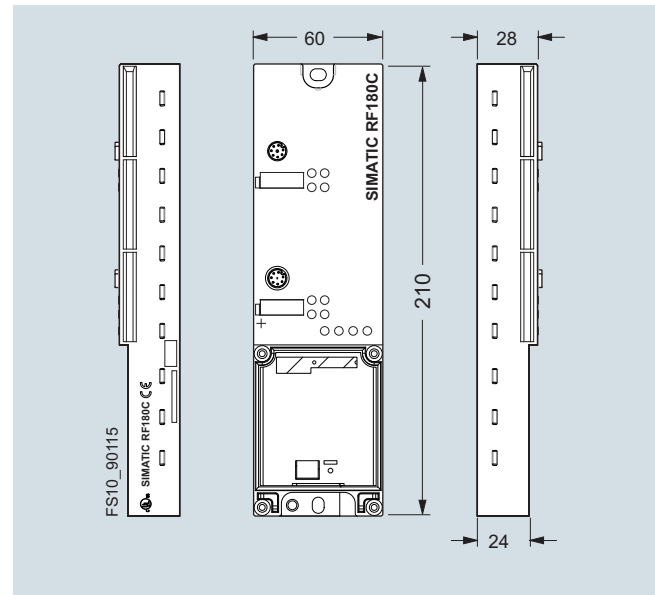

SIMATIC RF180C, RF182C, RFID 181EIP communication module

Communication modules

SIMATIC RF170C

Overview



The SIMATIC RF170C is a communication module for connecting the SIMATIC identification systems to the ET 200pro distributed I/O system. The readers (SLGs) of all RFID systems as well as the MV400 code-reading systems can be operated on the SIMATIC RF170C.

Thanks to the high degree of protection and ruggedness, ET 200pro is particularly suitable for machine-level use. The modular structure with PROFIBUS and PROFINET connection systems allows them to be used in all applications. The uniform plug-in connection system ensures rapid commissioning.

Benefits



- Two parallel reader channels ensure real-time mode at dynamic read points.
- Through selection of the corresponding head module, a connection of the RFID systems via PROFIBUS or PROFINET is possible.
- The modular design with interface modules for PROFIBUS and PROFINET supports universal implementation.
- Reader connection using an 8-pin M12 connector for quick mounting of all components.
- Powerful hardware guarantees rapid data exchange with the reader (SLG) so that data is made available to the application even faster.
- Very easy downloading of firmware via the SIMATIC Manager for function expansions and error rectification ensure high availability of the identification system.
- Adjustable and parameterizable identification-system-specific diagnostics facilitate easy commissioning and troubleshooting.
- A wide selection of pre-assembled connecting cables can be ordered for ET 200pro and SIMATIC RF170C. This saves time and money during installation and assures better quality.

Application

The ET 200pro distributed I/O system with the SIMATIC RF170C communication module has been specially designed for a wide range of applications in industrial automation and logistics. Thanks to the high degree of protection of IP67, the SIMATIC RF170C can be installed without a control cabinet.

Used primarily for the SIMATIC RF170C:

- Mechanical engineering, automation systems, conveyor systems
- Ancillary assembly lines in the automobile industry/suppliers
- Small assembly lines

Design

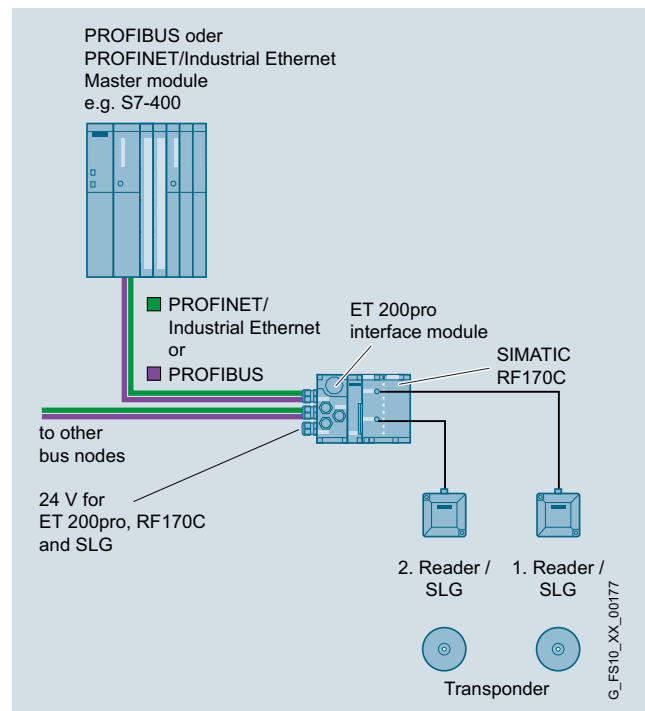

SIMATIC RF170C communications module

Function

The SIMATIC RF170C comprises an electronics module and a connection block that must be ordered separately. The interface module is available in PROFIBUS or PROFINET version.

- For the PROFIBUS connection, you can choose between ECOFAST, M12, 7/8" or screwed cable gland for the connection system.
- For the PROFINET interface module, the M12, 7/8" or push pull (RJ45 or SCRJ FO) connection system is available.

Integration of SIMATIC RF170C into SIMATIC STEP 7 is already implemented in the TIA Portal but can also be accomplished by means of a Hardware Support Package (HSP). The GSD file of the ET 200pro system is available for integration into non-Siemens systems.

A pre-assembled reader cable, available in lengths from 2 m to 50 m, is used to connect one or two readers to the communication module. The cable can also be assembled by the customer as required.

The data in the transponder is accessed by direct addressing using absolute addresses.

Error messages and operating states (transponder in the field, transmission, etc.) are indicated additionally by means of LEDs and simplify commissioning and service.

The SIMATIC RF170C has two reader interfaces from which the readers are also supplied with power. In the SIMATIC RF170C, the power supply for the readers has an electronic fuse. The maximum permissible current per SIMATIC RF170C for the readers is 0.8 A. It is of no importance here whether the current is drawn by one or two readers.

The data in the transponder or on the data matrix code can be accessed direct using absolute addresses (FB/FC 45, FB/FC 55). When the ET 200pro is operated with a PROFINET interface, use of the FB (FB 45, FB 55) is mandatory. The RF170C also supports the functions of the Ident Library. The Ident Library is already integrated in the TIA Portal and offers functions that are very easy to parameterize.

Communication between the SIMATIC RF170C and the controller is acyclic. Consequently, a very large amount of data can be transferred to/from the SIMATIC RF170C without overloading the bus cycle. This has advantages when transferring large volumes of data. The SIMATIC RF170C can also process concatenated transponder commands very quickly in this mode.

Notice: When connecting high-speed RFID systems (e.g. RF300), the data throughput can decrease due to the distributed configuration of the ET 200pro. Therefore use the data throughput calculation tool when configuring. You can find the tool on the DVD with article number 6GT2080-2AA20.

Technical specifications

Article number	6GT2002-0HD00
Product type designation	RF170C communication module
Suitability for operation	Distributed IO ET 200pro together with RF200/300/600, MV300/400, MOBY D/E/I/U and RS232 devices
Transmission rate	
Transfer rate at the point-to-point connection serial maximum	115.2 kbit/s
Interfaces	
Design of the interface for point-to-point connection	RS422/RS232 via connection block
Number of readers connectable	2
Type of electrical connection	
• of the backplane bus	ET 200pro backplane bus
• of the PROFIBUS interface	(according to the head module)
• of Industrial Ethernet interface	(according to the head module)
• for supply voltage	ET 200pro backplane bus
Design of the interface to the reader for communication	Internal plug to the connection block
Mechanical data	
Material	Thermoplastic (Valox 467, fiberglass reinforced)
Color	IP Basic 714
Tightening torque of the screw for securing the equipment maximum	1.5 Nm
Supply voltage, current consumption, power loss	
Supply voltage	
• at DC Rated value	24 V
• at DC	20 ... 30 V
Consumed current at DC at 24 V	
• without connected devices typical	0.13 A
• with connected devices maximum	1 A
Permitted ambient conditions	
Ambient temperature	
• during operation	-25 ... +55 °C
• during storage	-40 ... +70 °C
• during transport	-40 ... +70 °C
Protection class IP	IP67
Shock resistance	According to IEC 61131-2
Shock acceleration	300 m/s ²
Vibrational acceleration	100 m/s ²
Design, dimensions and weight	
Width	90 mm
Height	130 mm
Depth	35 mm
Net weight	0.27 kg
Mounting type	ET 200pro rack
Cable length for RS422 interface maximum	1 000 m



Communication modules

SIMATIC RF170C

Article number	6GT2002-0HD00
Product type designation	RF170C communication module
Product properties, functions, components general	
Display version	(see connection block)
Product function transponder file handler can be addressed	No
Protocol is supported	Yes
• S7 communication	
Type of parameterization	HSP
Type of programming	FB 45, FB 55, ident profile, (FC 45/55 with limited functionality)
Type of computer-mediated communication	acyclic communication
Standards, specifications, approvals	
Certificate of suitability	CE, FCC, cULus
MTBF	77 y
Accessories	
Accessories	Connection block for RF170C

	Article No.
MOBY D reader cable PUR material, CMG approval, suitable for cable carriers, 2 m	6GT2691-4FH20
	
Sealing caps M12 for unused reader connections Minimum order quantity 10 units, price per 100 units	3RX9802-0AA00
DVD „RFID Systems Software & Documentation“	6GT2080-2AA20

Selection and ordering data

	Article No.
SIMATIC RF170C communication module For connecting to the distributed I/O system ET 200pro	6GT2002-0HD00
Accessories	
Connection block for SIMATIC RF170C For connecting 2 readers via an M12 connector	6GT2002-1HD00
	
Reader cable for SIMATIC RF200 / RF300 / RF600 / MV440 Or extension cable MOBY D and SIMATIC RF200 / RF300 / RF600 / MV400, PUR material, CMG approved, suitable for cable carriers	
	
2 m, straight connector	6GT2891-4FH20
5 m, straight connector	6GT2891-4FH50
10 m, straight connector	6GT2891-4FN10
20 m, straight connector	6GT2891-4FN20
50 m, straight connector	6GT2891-4FN50
2 m, plug angled at reader	6GT2891-4JH20
5 m, plug angled at reader	6GT2891-4JH50
10 m, plug angled at reader	6GT2891-4JN10

Dimensional drawings

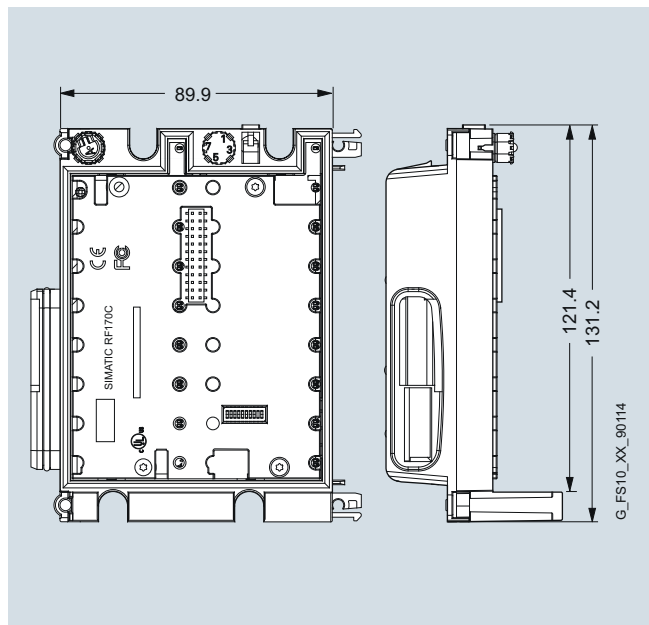

SIMATIC RF170C communications module

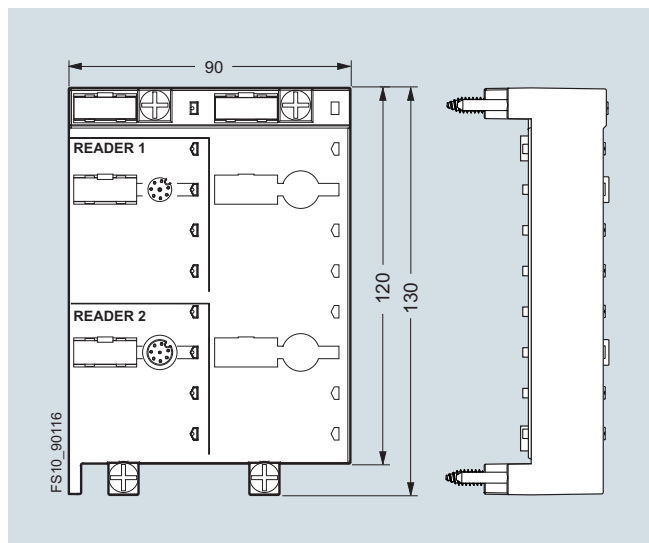

Connector block for SIMATIC RF170C

Overview



The SIMATIC RF120C is a communication module for connecting the SIMATIC identification systems directly to the SIMATIC S7-1200. The readers of all RFID systems as well as the MV400 optical readers can be operated on the SIMATIC RF120C.

Integration into the TIA Portal and the uniform plug-in connection systems permit fast and simple commissioning.

Benefits



- Space savings thanks to the extremely compact design of the identification system connected directly to the controller
- Due to the intuitive parameterization of the RF120C and the reader via the SIMATIC device configuration, the manual is mostly no longer required.
- The Ident Library is integrated in the TIA Portal and offers Ident instructions (e.g. Read, Write) that are very easy to use and thus facilitate programming and commissioning without the need for documentation.
- Reader connection using a sub-D connector on the RF120C for fast installation of all components
- Powerful hardware ensures maximum data exchange speed with the reader so that data is made available to the application even faster.
- Very easy downloading of functional expansion and error rectification firmware for RF120C and readers via the TIA Portal ensures high availability of the identification system

Application

The SIMATIC S7-1200 controller with the RF120C communication module has been developed for all simple control applications including identification tasks.

Due to its technical setup with IP 20 degree of protection, the S7-1200 is designed for use in the control cabinet.

Main applications for SIMATIC RF120C:

- Mechanical engineering, automation systems, conveyor systems
- Ancillary assembly lines in the automobile industry/suppliers
- Small assembly lines

Design

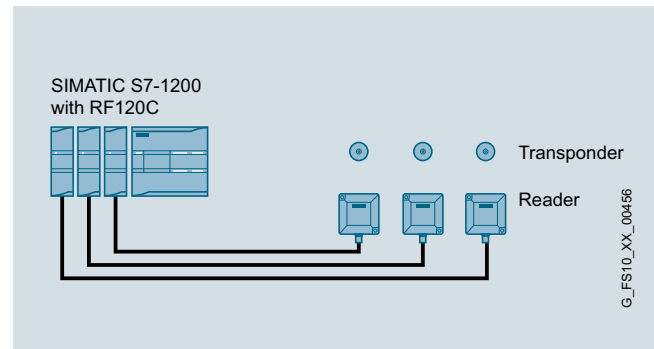

SIMATIC RF120C communication module

Function

The SIMATIC RF120C communications module is positioned to the left of the S7-1200 CPU. It enables a maximum of three RF120Cs to be operated on one S7-1200 CPU.

The reader is powered from the RF120C. The RF120C is provided with voltage via a screw-type terminal connector which is included in the scope of delivery.

For programming in the controller, a library is available with simple instructions such as Read/Write for accessing the transponder data. These instructions can also be used for other identification communication modules that are connected to the S7-1200 via Profibus/Profinet, e.g. for ASM 456 and RF180C. Furthermore, the library blocks can also be used for the SIMATIC S7-1500 so that the identification communication modules can be operated there via Profibus/Profinet.

Error messages and operating states (transponder in the field, transmission, etc.) are indicated additionally by means of LEDs behind the top cover of the RF120C. This makes commissioning and servicing considerably easier.

The RF120C features a sub D socket for connecting the reader. This also supplies the reader with voltage. The power supply of the reader is equipped with an electronic fuse. The maximum permissible current for a reader is 1 A.

The reader is connected to the RF120C with a pre-assembled reader cable which is available in different lengths. This 6GT2091-4Lxxx type cable can easily be extended with a type 6GT2891-4Fxxx cable in order to cover greater distances between the reader and the controller.

Communication between the SIMATIC RF120C and the controller is acyclic. Consequently, a very large amount of data can be transferred to/from the RF120C without overloading the bus cycle. This has advantages when transferring large volumes of data.



Communication modules

SIMATIC RF120C

Technical specifications

Article number	6GT2002-0LA00
Product type designation	RF120C communication module
Suitability for operation	SIMATIC S7-1200 together with RF200/300/600, MV400, MOBY D/U
Transmission rate	
Transfer rate at the point-to-point connection serial maximum	115.2 kbit/s
Interfaces	
Design of the interface for point-to-point connection	RS422
Number of readers connectable	1
Type of electrical connection	
• of the backplane bus	S7-1200 backplane bus
• for supply voltage	Screw terminals
Design of the interface to the reader for communication	D-sub, 9-pin, socket
Mechanical data	
Material	Xantar MX 1094
Color	Ti-grey 24L01
Tightening torque of the screw for securing the equipment maximum	0.45 Nm
Supply voltage, current consumption, power loss	
Supply voltage	
• at DC Rated value	24 V
• at DC	20 ... 30 V
Consumed current at DC at 24 V	
• without connected devices typical	0.03 A
• with connected devices maximum	1 A
Permitted ambient conditions	
Ambient temperature	
• during operation	0 ... 55 °C
• during storage	-40 ... +70 °C
• during transport	-40 ... +70 °C
Protection class IP	IP20
Shock resistance	According to IEC 61131-2
Shock acceleration	300 m/s ²
Vibrational acceleration	100 m/s ²
Design, dimensions and weight	
Width	30 mm
Height	100 mm
Depth	75 mm
Net weight	0.15 kg
Mounting type	S7-1200 rack
Cable length for RS422 interface maximum	1 000 m
Product properties, functions, components general	
Display version	4 LEDs for reader connection, 1 LED for device status
Product function transponder file handler can be addressed	No
Protocol is supported	
• S7 communication	Yes
Type of parameterization	HSP
Type of programming	Library with functions
Type of computer-mediated communication	acyclic communication
Standards, specifications, approvals	
Certificate of suitability	CE, FCC, cULus, KCC, C-Tick, FM, Ex: II 3G Ex nAA IIC T4 Gc
MTBF	196 y

Selection and ordering data

	Article No.
SIMATIC RF120C communication module	6GT2002-0LA00
Integrated in the S7-1200 controller for connection of a reader	
Accessories for all readers	
Reader cable for SIMATIC RF200 / RF300 / RF600 / MV400	
PUR material, CMG approval, suitable for cable carriers, straight reader connector	
	
2 m	6GT2091-4LH20
5 m	6GT2091-4LH50
10 m	6GT2091-4LN10
Accessories for extended us	
Extension cable for all readers	
PUR material, CMG approval, suitable for cable carriers	
	
2 m, straight connector	6GT2891-4FH20
5 m, straight connector	6GT2891-4FH50
10 m, straight connector	6GT2891-4FN10
20 m, straight connector	6GT2891-4FN20
50 m, straight connector	6GT2891-4FN50
2 m, plug angled at reader	6GT2891-4JH20
5 m, plug angled at reader	6GT2891-4JH50
10 m, plug angled at reader	6GT2891-4JN10
Reader adapter cable for MOBY D	6GT2691-4FH20
Material PUR, CMG approval, suitable for cable carriers, 2 m. A cable of the type 6GT2091-4L... is also required.	
	
DVD „RFID Systems Software & Documentation“	6GT2080-2AA20

Dimensional drawings

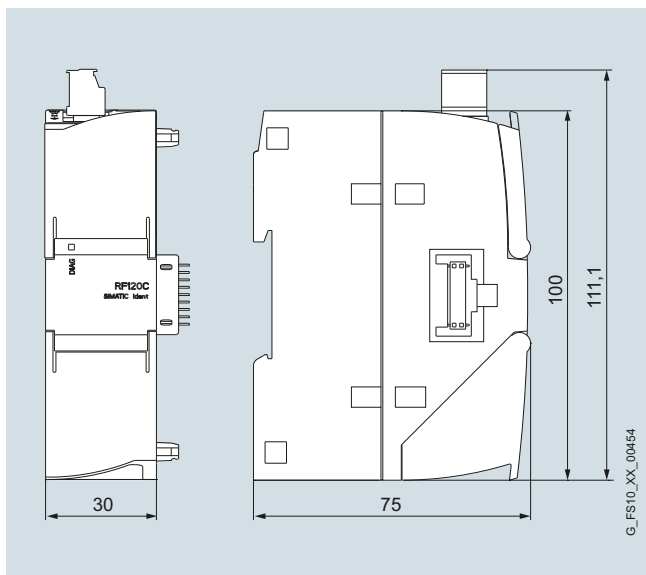

SIMATIC RF120C communication module

Communication modules

ASM 475

Overview



The ASM 475 is a powerful communication module for connecting the MOBY D, SIMATIC RF200, RF300, RF600 and SIMATIC MV400 identification systems to the S7-300 and ET 200M.

Application

The ASM 475 communication module integrates the identification systems into the following automation systems:

- SIMATIC S7-300
- S7-400, PC (CP5412 (A2)) over ET 200M
- SINUMERIK 840D/810D

A maximum of two readers can be connected in parallel and operated in parallel mode.

Design

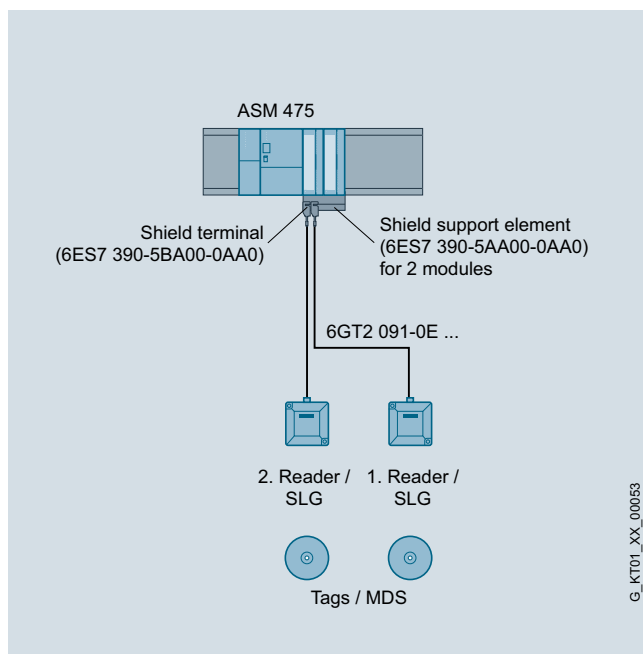

Function

As many as 8 ASM 475 communication modules can be plugged into one SIMATIC S7-300 rack and operated. For a multi-rack installation (maximum of 4), the ASM 475 communication modules can be plugged in and operated in each rack. This means that as many as 32 ASM 475s can be operated in the maximum configuration of a SIMATIC S7-300. The electrical isolation between the reader and SIMATIC S7-300 bus ensures a noise-resistant setup.

Error messages and operating states (transponder in field, command active, etc.) are indicated using LEDs.

Communication between the ASM 475 and S7-CPU takes place by means of acyclic P-bus message frames so that the useful data is transmitted very quickly and effectively. The ASM 475 is fully integrated into the diagnostics of the SIMATIC via a hardware support package (HSP). Depending on the PROFIBUS master, as many as 126 ET 200M modules can be operated on one PROFIBUS line.

The data in the transponder or Data Matrix Code is accessed direct by means of physical addresses using the ASM 475. The data is transferred between FB/FC 45, FB/FC 55 and ASM 475 at high speed and without placing a great load on the CPU.

Technical specifications



Article number	6GT2002-0GA10
Product type designation	ASM 475 communication module
Suitability for operation	SIMATIC S7-300, ET 200M together with RF200/300/600, MOBY D/E/I/U
Transmission rate	
Transfer rate at the point-to-point connection serial maximum	115.2 kbit/s
Interfaces	
Design of the interface for point-to-point connection	RS422
Number of readers connectable	2
Type of electrical connection	
<ul style="list-style-type: none"> • of the backplane bus • of the PROFIBUS interface • of Industrial Ethernet interface • for supply voltage 	S7-300 backplane bus (according to the head module) (according to the head module)
Design of the interface to the reader for communication	Screw-type or spring-loaded terminals
Mechanical data	
Material	Noryl
Color	anthrazit
Supply voltage, current consumption, power loss	
Supply voltage	
<ul style="list-style-type: none"> • at DC Rated value • at DC 	24 V 20 ... 30 V
Consumed current at DC at 24 V	
<ul style="list-style-type: none"> • without connected devices typical • with connected devices maximum 	0.1 A 1 A
Permitted ambient conditions	
Ambient temperature	
<ul style="list-style-type: none"> • during operation • during storage • during transport 	0 ... 60 °C -40 ... +70 °C -40 ... +70 °C
Protection class IP	IP20
Shock resistance	According to IEC 61131-2
Shock acceleration	150 m/s ²
Vibrational acceleration	10 m/s ²
Design, dimensions and weight	
Width	40 mm
Height	125 mm
Depth	120 mm
Net weight	0.2 kg
Mounting type	S7-300 rack
Cable length for RS422 interface maximum	1 000 m

Article number	6GT2002-0GA10
Product type designation	ASM 475 communication module
Product properties, functions, components general	
Display version	4 LEDs per reader connection, 2 LEDs for device status
Product function transponder file handler can be addressed	Yes
Protocol is supported	
<ul style="list-style-type: none"> • S7 communication 	Yes
Type of parameterization	Object manager, GSD
Type of programming	FB 45, FB 55, FC 56 (FC 45/55 with limited functionality) acyclic communication
Type of computer-mediated communication	
Standards, specifications, approvals	
Certificate of suitability	CE, FCC, UL/CSA
Accessories	
Accessories	Front connector with screw-type or spring-loaded terminals

Communication modules

ASM 475

Selection and ordering data

	Article No.
ASM 475 communication module For SIMATIC S7-300 and ET 200M, parameterizable	6GT2002-0GA10
Accessories	
Front connector (1 x per ASM 475) 	
<ul style="list-style-type: none"> with screw terminals with spring-loaded terminals 	6ES7392-1AJ00-0AA0 6ES7392-1BJ00-0AA0
Shield connecting element (80 mm wide for 2 x ASM 475)	6ES7390-5AA00-0AA0
Shield connection clamp (1 x per reader cable)	6ES7390-5BA00-0AA0
MOBY D connecting cable pre-assembled, between ASM 475 and reader D1xS, 9-pole Sub-D plug, PUR material, CMG approved, suitable for cable carriers	
	
5 m	6GT2491-4EH50
20 m	6GT2491-4EN20
50 m	6GT2491-4EN50
Extension cable SIMATIC RF200 / RF300 / RF600 / MV400, PUR material, CMG approval, suitable for cable carriers, straight connector	
	
2 m	6GT2891-4FH20
5 m	6GT2891-4FH50
10 m	6GT2891-4FN10
20 m	6GT2891-4FN20
50 m	6GT2891-4FN50

Article No.

SIMATIC RF200 / RF300 / RF600 / MV400 connecting cable

pre-assembled, between the ASM 475 and RF200 / RF300 / RF600 / MV400, IP65, straight connector, PUR material, suitable for cable carriers, CMG approval, in the following lengths¹⁾:



2 m

6GT2891-4EH20

5 m

6GT2891-4EH50

DVD „RFID-Systems Software & Documentation“

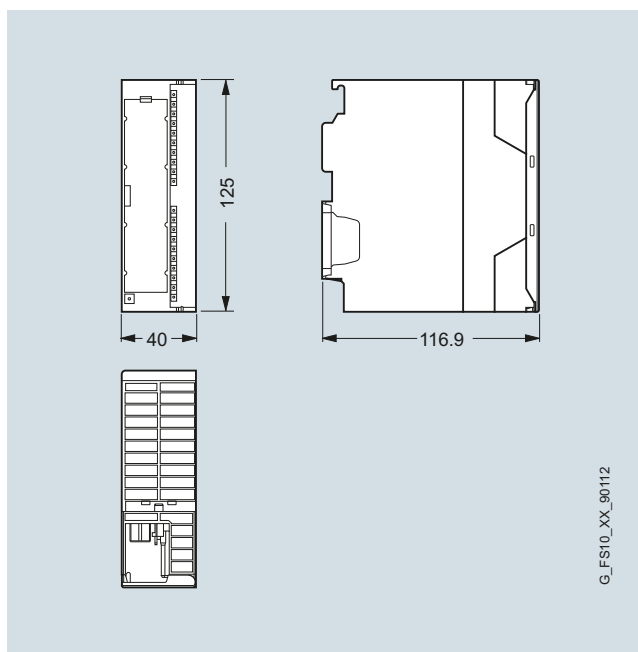
6GT2080-2AA20

G_FS10_XX_90112

ASM 475 communication module

¹⁾ The connecting cables can be extended using RF300 connecting cables of type 6GT2891-4Fxxx. These connecting cables are available in the lengths 2 m, 5 m, 10 m, 20 m and 50 m.

Overview

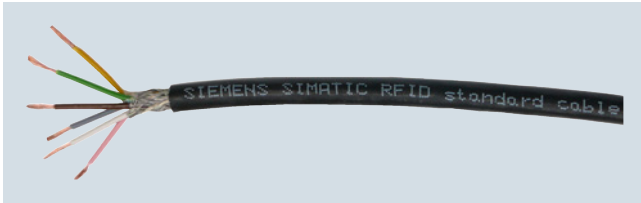

RFID standard cable that is used with SIMATIC RFID systems preassembled in various lengths.

Benefits



Due to the cETLus certification with CMG test and marking, the cable can also be installed in fire protection critical building parts (e.g. vertical installation in a cable duct).

The SIMATIC RFID standard cable can also be used in dynamic applications such as tow chains with a minimum bending radius of 75 mm.

Application

In addition to the normal areas of application in industry, the cable can also be laid:

- In areas subject to high heat
- For highly flexible applications (e.g. in cable carriers)
- In oil-contaminated industrial environments
- In outdoor applications exposed to solar radiation (UV radiation)









Technical specifications

Product type designation	SIMATIC RFID standard cable
Product description	Highly flexible communication line (6-wire)
Also suitable for use	in continuous motion applications, such as with drag chains
Cable designation	L-YC11Y 6x1x0.25 6x24AWG CMG
Electrical data	
Loop resistance per length/maximum	160 Ω/km
Mechanical data	
Number of electrical wires	6
Type of screen	Tin-plated braided shield made of copper wires with 0.13 mm diameter (36 AWG)
Wire diameter of the AWG24 wire	0.70 mm
Outer diameter	
• of the inner conductor	0.70 mm
• of the wire insulation	1.2 mm
• of the cable sheath	5.4 mm
Symmetrical tolerance of the outer diameter/of the cable sheath	0.2 mm
Material	
• of the wire insulation	PVC
• of the cable sheath	PUR

Product type designation	SIMATIC RFID standard cable
Color	
• of the data wire insulation	white / yellow / gray / pink / brown / green
• of the cable sheath	Black
Bending radius	
• for one-off bending / minimum permissible	21,6 mm
• for repeated bending / minimum permissible	43 mm
• with continuous bending	75 mm
Number of bending cycles	3 million
Number of bending cycles / note	Suitable as trailing cable for 3 million bending cycles with a bending radius of 75 mm
ensile load / maximum	200 N
Permitted ambient conditions	
Ambient temperature	
• during operation	-30 °C ... 80 °C
• during storage	-30 °C ... 80 °C
• during transport	-30 °C ... 80 °C
• during installation	-30 °C ... 80 °C
Ambient temperature / comment	Electrical properties measured at 20 °C
Behavior in fire	
	Flame-retardant acc. to IEC 60332-1-2
Resistance	
• to mineral oil	resistant
• to grease	resistant
• Radiological resistance / to UV radiation	resistant
Product properties, functions, components / general	
• Halogen-free	No
• Silicon-free	Yes
Standards, specifications, approvals	
• UL listing / at 300 V rating	Yes: CMG
• UL listing / at 600 V rating	No

RFID standard cables

Selection and ordering data

	Article No.		Article No.
MOBY D, connecting cable ASM 475 - SLG D1xS 5 m 20 m 50 m	6GT2491-4EH50 6GT2491-4EN20 6GT2491-4EN50	RF200/300/600, connecting cable ASM 456, RF160C, RF170C, RF180C, RF182C reader, optical code reader device Can also be used as RF200/300/600, MOBY D extension cable to ASM 456, RF160C, RF170C, RF180C, RF182C, straight connector	
MOBY D, connecting cable PC (RS232) - SLG D1x  5 m 20 m	6GT2691-4BH50 6GT2691-4BN20	 2 m 5 m 10 m 20 m 50 m	6GT2891-4FH20 6GT2891-4FH50 6GT2891-4FN10 6GT2891-4FN20 6GT2891-4FN50
MOBY D, connecting cable ASM 456, RF160C, RF170C, RF180C, RF182C - SLG D1xS  2 m	6GT2691-4FH20	RF300, connecting cable PC (RS232) - RF380R 5 m; 24 V connection with M12 plug	6GT2891-4KH50
RF200/300/600, connecting cable ASM 475 - reader  2 m 5 m	6GT2891-4EH20 6GT2891-4EH50	 5 m; 24 V connection with open ends	6GT2891-4KH50-0AX0
RF200/300/600, RF120C connecting cable  2 m 5 m 10 m	6GT2091-4LH20 6GT2091-4LH50 6GT2091-4LN10	Accessories Connecting cable, communication module - reader, without connector 50 m 120 m 800 m	6GT2090-4AN50 6GT2090-4AT12 6GT2090-4AT80
RF200/300/600, M12 connecting cable ASM 456, RF160C, RF170C, RF180C, RF182C reader Reader connector, angled  2 m 5 m 10 m	6GT2891-4JH20 6GT2891-4JH50 6GT2891-4JN10	M12 connector, 8-pin with screw-type terminal, for max. 0.5 mm ² wires. Ordering quantity 5 units or multiples thereof. <ul style="list-style-type: none"> Female for Reader Male for communication modules ASM 456, RF160C, RF170C, RF180C, RF182C, RFID 181EIP 	6GT2090-0BD00 6GT2090-0BE00
		M12 connector, 4-pin  Male with screw-type terminal for wide-range power supply (see page 2/125). Pack of 3.	6GK1907-0DB10-6AA3

Overview

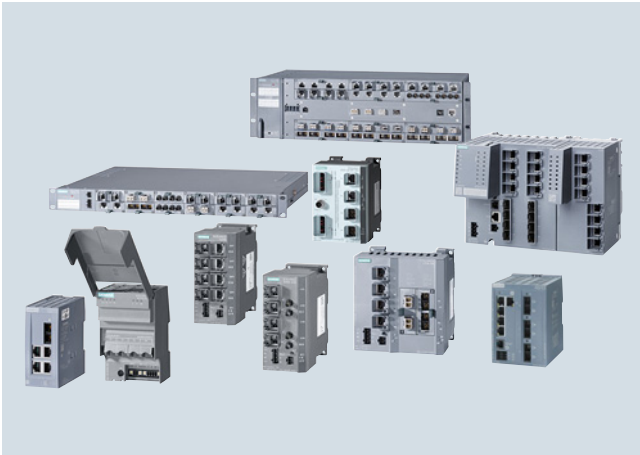

SCALANCE X Industrial Ethernet switches

The SCALANCE product family is designed primarily for use in diverse industrial applications.

It provides everything for ultra efficient industrial networks and bus systems: Powerful, future-proof network components for reliable operation in any type of industrial environment:

- A cabling system for fast, pre-assembled connection on site.
- Fast redundancy for high availability.
- Process fault diagnostics for permanent monitoring of the network components.

The SCALANCE network components are characterized by:

- Comprehensive portfolio tailored to data communication requirements in different industries.
- Coordinated network components from a single source.
- Conformity according to global standards, e.g. IEEE 802.3, IEEE 802.11n.
- Integration in the TIA Portal.
- Future-proof and innovative technology.
- 5-year warranty on all SCALANCE products with delivery date as of January 1, 2015

SCALANCE offers a comprehensive portfolio of integrated industrial communication solutions. With this portfolio, you will find the perfect connection for every industrial application – from the automotive to the chemical industry, as well as in OEM manufacturing and process industries.

SCALANCE product family

SCALANCE X – Industrial Ethernet switches

A graded portfolio of Industrial Ethernet switches in different designs and performance classes enables optimum solutions for all types of switching tasks – not only in harsh industrial environments.

SCALANCE W – Industrial Wireless LAN

Wireless communication with Industrial Wireless LAN (IWLAN) opens up more flexibility in network planning and even provides protection against failures with respect to personnel and machine safety.



Industrial Wireless LAN SCALANCE W

SCALANCE M – Industrial modems and routers

Network widely distributed plants or machines with a wide range of modems and routers - via telephone, mobile wireless or Internet, depending on requirements.

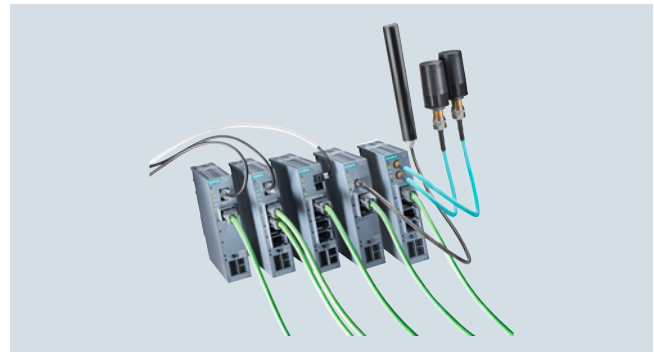

SCALANCE S – Industrial Security

The Industrial Security product portfolio offers security solutions specifically for industrial automation technology to avoid risks with respect to data security.



Selection Tools

To help you find the right Industrial Ethernet switches, configure modular versions, and select SIMATIC Ident devices, the TIA Selection Tool is available at:

<http://www.siemens.com/tia-selection-tool>

SCALANCE network components

Industrial Ethernet Switches SCALANCE X

Overview

With the SCALANCE X product family, Siemens offers a wide range of switches for industrial use. They can be used for all Ethernet-based SIMATIC Ident devices (e.g. MV400 optical reader, RF600 reader, RF180C communication module) to establish the network architecture.

Some of the switches recommended by Siemens are listed under the accessories for the SIMATIC Ident devices (e.g. the SCALANCE X108PoE Industrial Ethernet with the MV440 optical reader).

In this section, you can find an extract from the SCALANCE portfolio as a supplement.

You can find more information and the entire portfolio of SCALANCE switches, cables and network accessories, with the associated order numbers, in the Catalog IK PI.

Product versions

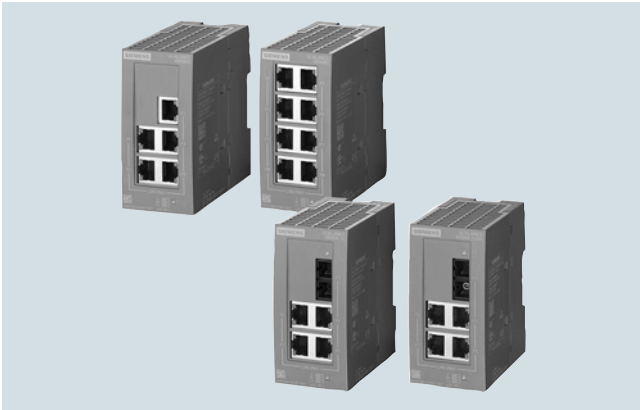

SCALANCE XB-200

- Managed switches for setting up 10/100 Mbps Industrial Ethernets in a line, star or ring topology (RM integrated)
- Electrical and optical nodes or network connections can be implemented by means of 8 or 16 RJ45 ports (10/100 Mbps) or 3 fiber-optic ports (100 Mbps)
- SCALANCE XB208; 8 x 10/100 Mbps RJ45 port, electrical
- SCALANCE XB205-3; 5 x 10/100 Mbps RJ45 port, electrical; 3 x 10/100 Mbps ports, fiber-optic cable
- SCALANCE XB216; 16 x 10/100 Mbps RJ45 port, electrical
- Rugged plastic enclosure
- Diagnostics on the device by means of LEDs (power, link status, data communication)
- The devices feature SNMP access, integral web server remote diagnostics and signaling over the network
- Diagnostics and parameter assignment via website or console port
- Supports both PROFINET and Ethernet/IP industrial protocols in the same device (software-switchable)
- All device versions available with default setting for both PROFINET and Ethernet/IP

SCALANCE XB005 and SCALANCE XB008 SCALANCE XB005G and SCALANCE XB008G (Gigabit)

- Unmanaged switches for setting up Industrial Ethernet networks in line and star structures
- Enclosure for space-saving installation in control cabinets or boxes on a standard mounting rail
- SCALANCE XB005 and SCALANCE XB008
5 or 8 x 10/100 Mbps RJ45 ports, electrical
- SCALANCE XB005G and SCALANCE XB008G (Gigabit)
5 or 8 x 10/100/1 000 Mbps RJ45 ports, electrical
- SCALANCE X10 unmanaged switches for setting up Industrial Ethernet networks in line and star structures
- Enclosure for space-saving installation in control cabinets or boxes on standard mounting rails
- SCALANCE XB005 and SCALANCE XB008
5 or 8 x 10/100 Mbps RJ45 ports, electrical
- SCALANCE XB005G and SCALANCE XB008G (Gigabit)
5 or 8 x 10/100/1 000 Mbps RJ45 ports, electrical

SCALANCE X108PoE

- Unmanaged switches for setting up electrical Industrial Ethernet star and line topologies
- with eight electrical ports, two of which have Power-over-Ethernet functionality
- Diagnostics on the device using LEDs (power, link status, data traffic) and signaling contact (message screen can be set using a button on the device)
- The RJ45 ports are suitable for industrial use and have additional retaining collars: Optimized for connecting the IE FC RJ45 Plug 180.

Benefits

get Designed for Industry

**SCALANCE XB005 and SCALANCE XB008
SCALANCE XB005G and SCALANCE XB008G (Gigabit)
SCALANCE X108PoE**

- Implementation of simple and low-cost machine networking
- Space-saving installation thanks to small, compact design
- Can be used in industrial environments
- Quick commissioning without configuration
- Easy on-site diagnostics via LEDs
- Use of uncrossed connecting cables possible thanks to the integrated auto crossover function
- Reduction of network installation costs by transmitting data and energy (Power-over-Ethernet) via the conventional 4-core Industrial Ethernet cable (only SCALANCE X108PoE), for example, for MV400 optical reader
- Additional power supply units can be omitted thanks to generating the Power-over-Ethernet voltage (48 V DC) direct at the switch (SCALANCE X108PoE only), for MV400 optical reader, for example.

SCALANCE XB-200

- Ideal solution for configuring Ethernet line, ring and star topologies
- High network availability due to design of redundant ring structures on the basis of high-speed redundancy (HRP), PROFINET-compliant ring redundancy (MRP), redundancy manager integrated
- Quick and easy diagnostics with LEDs on the device, using integrated Web server and via SNMP
- Integration of SCALANCE XB-200 switches in the existing network management infrastructure, e.g. SINEMA Server, with SNMP access point
- Load limiting when using multicast-based protocols (Voice over IP, Video) thanks to IGMP Snooping/Querier and additional multicast and broadcast limiting per port
- Uncrossed connecting cables can be used due to the integrated auto crossover function
- Support of the two industrial protocols, PROFINET and Ethernet/IP, in the same device
- Low-maintenance operation due to fanless construction
- Support of VLANs permits integration into Enterprise Security Policies

Application

The unmanaged Industrial Ethernet switches of the SCALANCE XB-000 line allow cost-effective solutions for setting up small, electrical/optical star or line topologies with switching functionality in machines or plant units. The enclosure is designed for space-saving installation in a control cabinet on a standard rail.

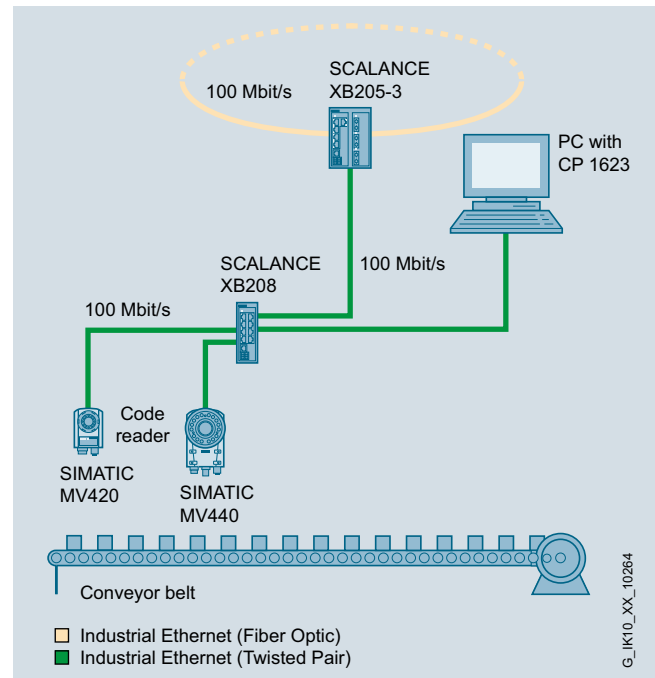

Integration of the SIMATIC MV420 and MV440 into the automation network

The SCALANCE XB-200 Industrial Ethernet switches are simple, low-cost Industrial Ethernet switches that contain the necessary software functionalities for automation with various protocols. The devices with degree of protection IP20 are designed for operation in the control cabinet.

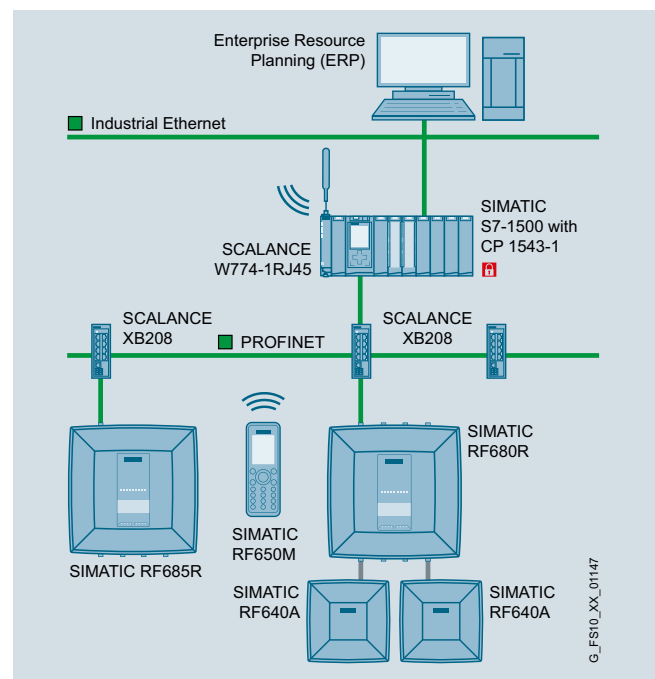

Connection of SIMATIC RF685R and RF680R to PROFINET

SCALANCE network components

Industrial Wireless LAN SCALANCE W

Overview

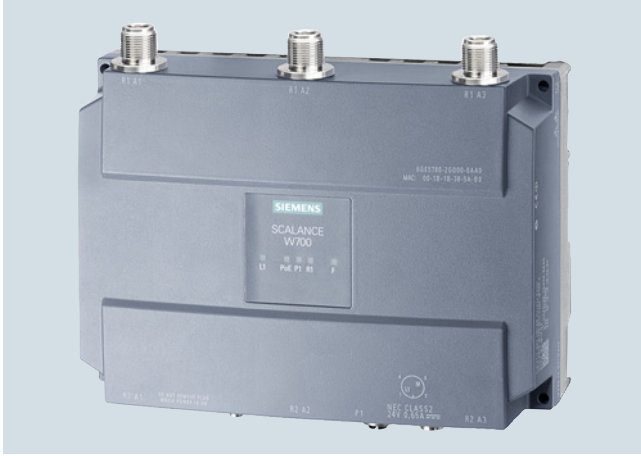

With the SCALANCE product family, Siemens offers a wide range of Industrial Wireless LAN network components for industrial use. They can be used for all Ethernet-based SIMATIC Ident devices (e.g. MV400 optical readers, RF600 reader, RF180C communication module) to establish a wireless network architecture.

Some of the IWLAN components recommended by Siemens are listed under the accessories for the SIMATIC Ident devices (e.g. SCALANCE W788-1 M12 for the SIMATIC RF650M handheld terminal (see page 3/41 in Catalog ID 10, 2016).

The SCALANCE W products provide a combination of reliability, ruggedness and security in a single product:

- For use by industrial and automation customers
- For outdoor use under demanding climatic conditions
- For low-cost integration into the control cabinet or in devices

Mobile end devices (e.g. SIMATIC RF650M) allow for an uninterrupted flow of information from the enterprise level right through to the production level. This means that information can be provided quickly, reliably and easily at the right place and at the right time by wireless.

In this section, you can find an extract from the SCALANCE W-700 portfolio as a supplement.

You can find more information and the entire portfolio of SCALANCE W, cables, antennas and antenna accessories, with the associated order numbers, in Catalog IK PI.

Product versions

SCALANCE W788-1 M12

A radio card is permanently installed, functional scope can be expanded by using a KEY-PLUG W780 iFeatures.

SCALANCE W788-2 M12

Two radio cards are permanently installed, functional scope can be expanded by using a KEY-PLUG W780 iFeatures.

Benefits

get Designed for Industry

- Predictable data traffic (deterministic response) and defined response times on the wireless link
- Reliable wireless link, e.g. by using MIMO technology and monitoring the wireless link
- Cost savings due to one single wireless network both for process-critical data and for non-critical communication
- Future-proof because all products are compatible with the internationally recognized WLAN standard IEEE 802.11n, suitable for license-free 2.4 GHz and 5 GHz frequency bands (ISM bands)
- Reduced operating costs since there is no wear and tear on rotating and moving plant sections
- Investment protection because flexible feature expansions (iFeatures) are possible using the KEY-PLUG

Application

The access points of the SCALANCE W700 product line are designed for both industrial use and for demanding climatic requirements outdoors.

Versions for the inexpensive integration into cabinets or machines are also available. They provide a reliable wireless link, redundancy mechanisms, and fast handover of nodes from one access point to the next (roaming). This allows processes to be monitored and loss of production due to machine downtimes to be avoided.

Industrial Wireless LAN (IWLAN) can also be used in time-critical applications in factory automation (PROFINET) or for safety-related signals (PROFIsafe).

SCALANCE W products are silicone-free and can therefore also be used in paint shops.

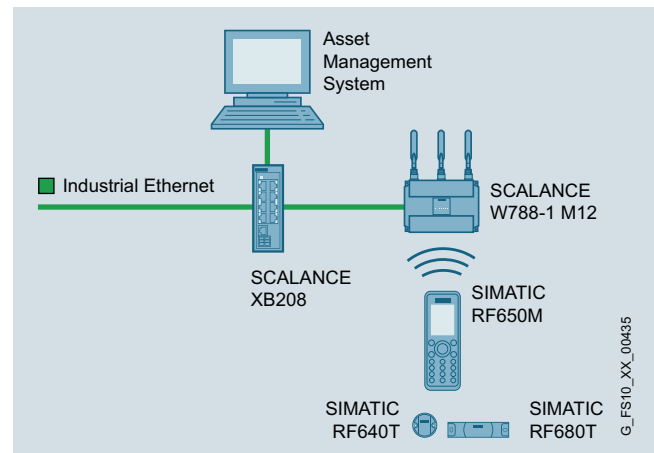

Mobile RFID data acquisition system, connected via SCALANCE W788-1 M12

Appendix



6/2	Training
6/3	Siemens Automation Cooperates with Education
6/5	Partners at Siemens Industry Automation and Drives Technologies
6/6	Online Services
6/8	Industry Services
6/12	Software licenses
6/14	Index
6/15	Article number index
6/18	Terms and conditions of sale and delivery

Appendix

SITRAIN – Training for Industry

You benefit from practical training right from the manufacturer

SITRAIN Training for Industry provides you with comprehensive support in solving your tasks.

Training right from the manufacturer enables you to make better choices with more confidence in your decision-making processes.

SITRAIN Training means:

- Less time for commissioning, maintenance and servicing
- Optimized production operations
- Safe engineering and commissioning
- Shorter start-up times, reduced downtimes and faster fault clearance
- Swift elimination of deficits in existing plants
- Avoidance of costly planning errors right from the start
- Flexible plant adaptation to market requirements
- Ensure quality standards in production
- Increased employee satisfaction and motivation
- Shorter orientation periods in case of technology or personnel change



Contact

Visit our website at:

www.siemens.com/sitrain

or let us advise you personally. You can request our latest training catalog from:

SITRAIN – Training for Industry Customer Support Germany:

Phone: +49 911 895-7575

Fax: +49 911 895-7576

E-mail: info@sitrain.com



Important key data

Top trainers

Our trainers are skilled specialists with direct and extensive practical experience. Course developers have close contact with product development and directly pass on their knowledge to the trainers, and with that at the end to you.

Practical experience

Practice makes perfect – that's why we attach greatest importance to hands-on learning. Practical exercises can comprise up to half of the course time. You can therefore immediately implement your new knowledge in your day-to-day work.

300 courses in 62 countries

We offer a total of about 300 local attendance courses. You can find us at more than 50 locations in Germany, and in 62 countries worldwide. To find out which course is held at which location, go to:

www.siemens.com/sitrain

Customized training

Would you prefer individual training instead? Our solution: We will provide a program tailored exactly to your personal requirements. Training can be carried out in our Training Centers or onsite at your company.

We instruct you using state-of-the-art training equipment which has been especially designed by our developers for the SITRAIN courses. This training approach will give you all the assurance you need.

The right mixture: Blended learning

Blended learning involves a combination of various training media. For example, a face-to-face course in a training center can be optimally supplemented by teach-yourself Web-based training (WBT) courses as preparation or follow-up. The add-on effect: Reduced traveling costs and periods of absence.



Unique support for educators and students in educational institutions

Cooperates
with Education

Automation

SIEMENS

Siemens Automation Cooperates with Education (SCE)

offers a global system for sustained support of technical skills. SCE supports educational institutions in their teaching assignment in the industrial automation sector and offers added value in the form of partnerships, technical expertise, and know-how. As the technological leader, our comprehensive range of services can support you in the knowledge transfer for Industry 4.0.

Our services at a glance

- Training curriculums for your lessons
- Trainer packages for hands-on learning
- Courses convey up-to-date specialist knowledge
- Support for your projects / textbooks
- Complete didactic solutions from our partners
- Personal contact for individual support

Training curriculums for your lessons



Use our profound industrial know-how for practice-oriented and individual design of your course. We offer you more than 100 didactically prepared training curriculums on the topics of automation and drives technology free of charge. These materials are perfectly matched to your curricula and syllabuses, and optimally suited for use with our trainer packages. This takes into account all aspects of a modern industrial solution: installation, configuration, programming, and commissioning. All documents, including projects, can be individually matched to your specific requirements.

Particular Highlights:

- The new SIMATIC PCS 7 curriculums and trainer packages. Using plant simulation, you can pass on basic, practice-oriented PCS 7 knowledge at universities within about 60 hours (= 1 semester).

- The new TIA Portal training materials for SIMATIC S7-1500 / S7-1200 / S7-300 are available in English, German, French, Italian, Spanish, Portuguese and Chinese for download.

www.siemens.com/sce/curriculum

Trainer packages for hands-on learning



Our SCE trainer packages offer a specific combination of original industrial components which are perfectly matched to your requirements and can be conveniently used in your course. These price-reduced bundles available exclusively to schools include innovative and flexible hardware and software packages.

SCE currently offers more than 80 SCE trainer packages including related equipment e.g. Micro Memory. These cover both the factory and process automation sectors. You can use them to impart the complete course contents on industrial automation at a very low cost.

Trainer packages are available for:

- Introduction to automation technology with LOGO! logic module
- PLC engineering with SIMATIC S7 hardware and STEP 7 software (S7-1500, S7-1200, S7-300 and TIA Portal)
- Operator control and monitoring with SIMATIC HMI
- Industrial networking over bus systems with SIMATIC NET (PROFINET, PROFIBUS, IO-Link)
- Sensor systems with VISION, RFID and SIWAREX
- Process automation with SIMATIC PCS 7
- Networked drive and motion technologies with SINAMICS/SIMOTION
- Power Monitoring Devices SENTRON PAC 4200
- Motor Management SIMOCODE
- CNC programming with SinuTrain

Important ordering notes:

Only the following institutions are authorized to obtain trainer packages: vocational schools, Colleges and Universities, in-house vocational training departments, non commercial research institutions and non commercial training departments.

To purchase a trainer package, you require a specific end-use certificate, which you can obtain from your regional sales office.

www.siemens.com/sce/tp

Appendix

Siemens Automation Cooperates with Education

Simplify your education in automation

Unique support for educators and students in educational institutions (continued)

Courses convey up-to-date specialist knowledge



Profit from our excellent know-how as the leader in industrial technologies. We offer you specific courses for automation and drive technology worldwide. These support you in the practice-oriented transferring of product and system know-how, are in conformance with curriculums, and derived from the training fields. Compact technical courses especially for use at universities are also available.

Our range of courses comprises a wide variety of training modules based on the principle of Totally Integrated Automation (TIA). The focus is on the same subject areas as with the SCE trainer packages.

Every PLC and drive course is oriented on state-of-the-art technology. Your graduates can thus be prepared optimally for their future professional life.

In some countries we are offering classes based on our training curriculums. Please inquire with your SCE contact partner.

www.siemens.com/sce/courses



Automation and drive technology is characterized by continuous and rapid developments. Service and Support therefore play an important role.

As a particular service, SCE supports technical authors with our know-how as well as with intensive technical consulting. Siemens library of special textbooks covering the industrial automation sector provides an additional resource for you and your students. These can be found at the SCE web site.

www.siemens.com/sce/contact
www.siemens.com/sce/books

Complete didactic solutions from our partners



Our partners for learning systems offer a wide range of training systems and solutions for use in your courses or laboratory.

These models have been designed based on our trainer packages and thus save you the time and cost of selfconstruction of individual components. The Partner systems provide you with simple and effective help in the fulfillment of your teaching assignment.

www.siemens.com/sce/partner

Contact for individual support

You can find your personal SCE contact on our Internet site. Your local SCE Promoter will answer all your questions concerning the complete SCE offering, and provide you with timely and competent information about innovations. When you encounter challenges, you can profit from our global team of excellence.

If a direct SCE contact is not listed for your country, please contact your local Siemens office.

www.siemens.com/sce/contact

SCE Support Finder for your Internet request

You are an educator and need support on the topic of industry automation? Send us your request:

www.siemens.com/sce/supportfinder

Discover
SCE



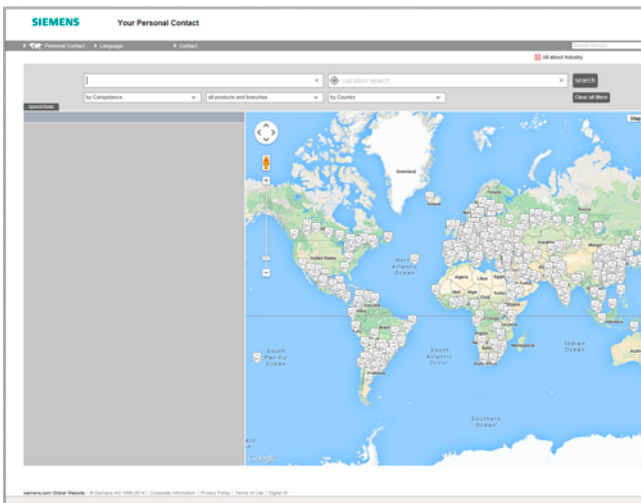

At Siemens we are resolutely pursuing the same goal: long-term improvement of your competitive ability. We are committed to this goal. Thanks to our commitment, we continue to set new standards in automation and drive technology. In all industries – worldwide.

At your service locally, around the globe for consulting, sales, training, service, support, spare parts ... on the entire Industry Automation and Drive Technologies range.

Your personal contact can be found in our Contacts Database at: www.siemens.com/automation/partner

You start by selecting

- the required competence,
- products and branches,
- a country,
- a city

or by a

- location search or
- person search.

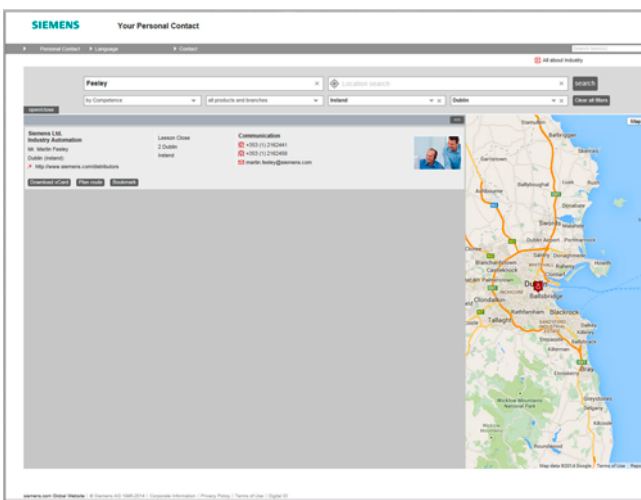
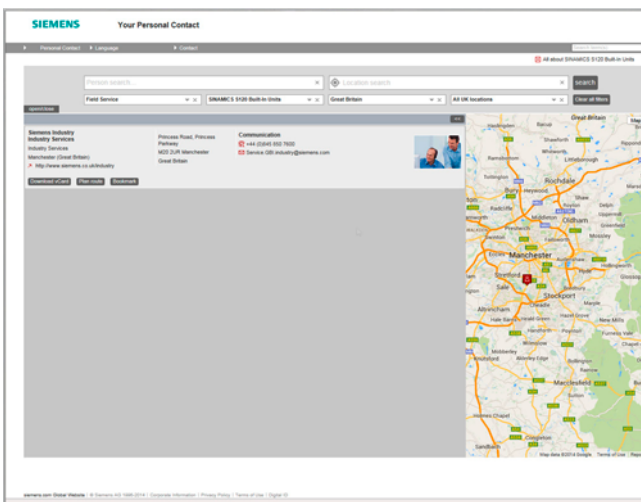

Appendix

Online Services

Information and Ordering Options on the Internet and DVD

The Future of Manufacturing on the Internet



Detailed knowledge of the range of products and services available is essential when planning and engineering automation systems. It goes without saying that this information must always be as up-to-date as possible.

Industry is on the threshold of the fourth industrial revolution as digitization now follows after the automation of production. The goals are to increase productivity and efficiency, speed, and quality. In this way, companies can remain competitive on the path to the future of industry.

You will find everything you need to know about products, systems and services on the internet at:

www.siemens.com/industry

Product Selection Using the Interactive CA 01 Automation and Drives Catalog

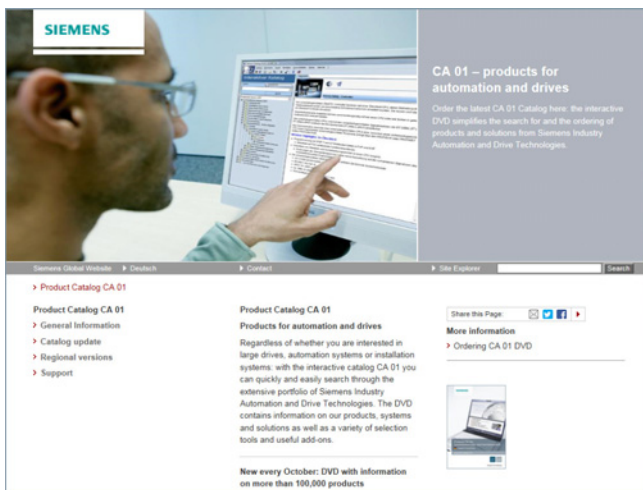

Detailed information together with user-friendly interactive functions:

The CA 01 interactive catalog covers more than 100,000 products, thus providing a comprehensive overview of the product range provided by Siemens.

You will find everything you need here for solving tasks in the fields of automation, switching, installation and drives. All information is provided over a user interface that is both user-friendly and intuitive.

You can order the CA 01 product catalog from your Siemens sales contact or in the Information and Download Center:

www.siemens.com/industry/infocenter

Information about the CA 01 interactive catalog can be found on the Internet at:

www.siemens.com/automation/ca01

or on DVD.

Easy Shopping with the Industry Mall

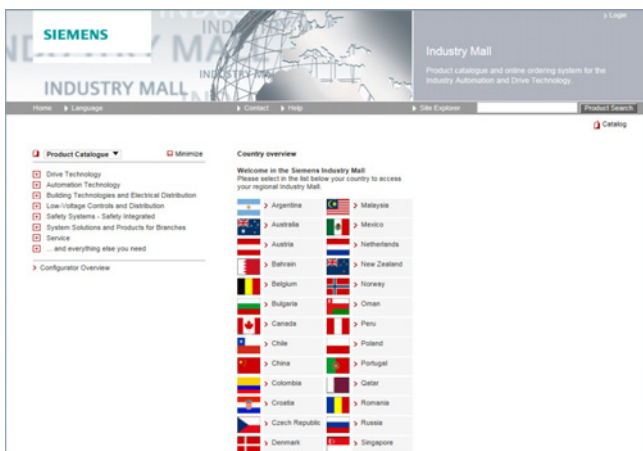

The Industry Mall is the electronic ordering platform of Siemens AG on the Internet. Here you have online access to a huge range of products presented in an informative and attractive way.

Data transfer via EDIFACT allows the whole procedure, from selection through ordering to tracking and tracing, to be carried out online. Availability checks, customer-specific discounts and bid creation are also possible.

Numerous additional functions are provided for your support. For example, powerful search functions make it easy to select the required products. Configurators enable you to configure complex product and system components quickly and easily. CAx data types are also provided here.

You can find the Industry Mall on the Internet at:

www.siemens.com/industrymall

Downloading Catalogs

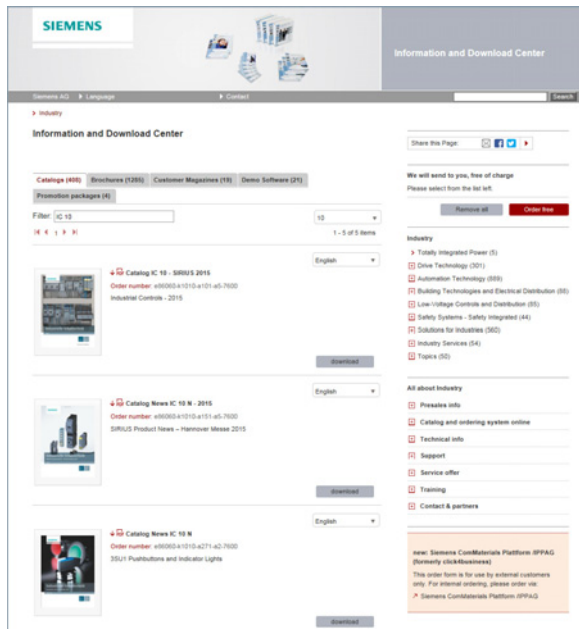

In addition to numerous other useful documents, you can also find the catalogs listed on the back inside cover of this catalog in the Information and Download Center. You can download these catalogs in PDF format without having to register.

The filter dialog above the first catalog displayed makes it possible to carry out targeted searches. If you enter "MD 3" for example, you will find both the MD 30.1 and MD 31.1 catalogs. If you enter "IC 10", both the IC 10 catalog and the associated news or add-ons are displayed.

Visit us at:

www.siemens.com/industry/infocenter

Social and Mobile Media

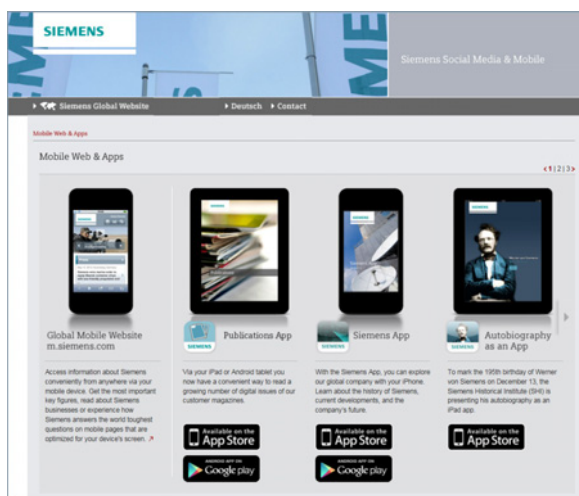

Connect with Siemens through social media: visit our social networking sites for a wealth of useful information, demos on products and services, the opportunity to provide feedback, to exchange information and ideas with customers and other Siemens employees, and much, much more. Stay in the know and follow us on the ever-expanding global network of social media.

To find out more about Siemens' current social media activities, visit us at:

www.siemens.com/socialmedia

Or via our product pages at:

www.siemens.com/automation or www.siemens.com/drives

Connect with Siemens Industry at our central access point to read all the news on the future of manufacturing, watch current videos and inform yourself about all the latest industry developments:

www.siemens.com/future-of-manufacturing/news.html



Discover the world of Siemens.

We are also constantly expanding our offering of cross-platform apps for smartphones and tablets. You will find the current Siemens apps at the App Store (iOS) or at Google Play (Android):

<https://itunes.apple.com/en/app/siemens/id452698392?mt=8>

<https://play.google.com/store/search?q=siemens>

The Siemens app, for example, tells you all about the history, latest developments and future plans of the company – with informative pictures, fascinating reports and the most recent press releases.

Appendix

Industry Services

Overview

Unleash potential – with services from Siemens

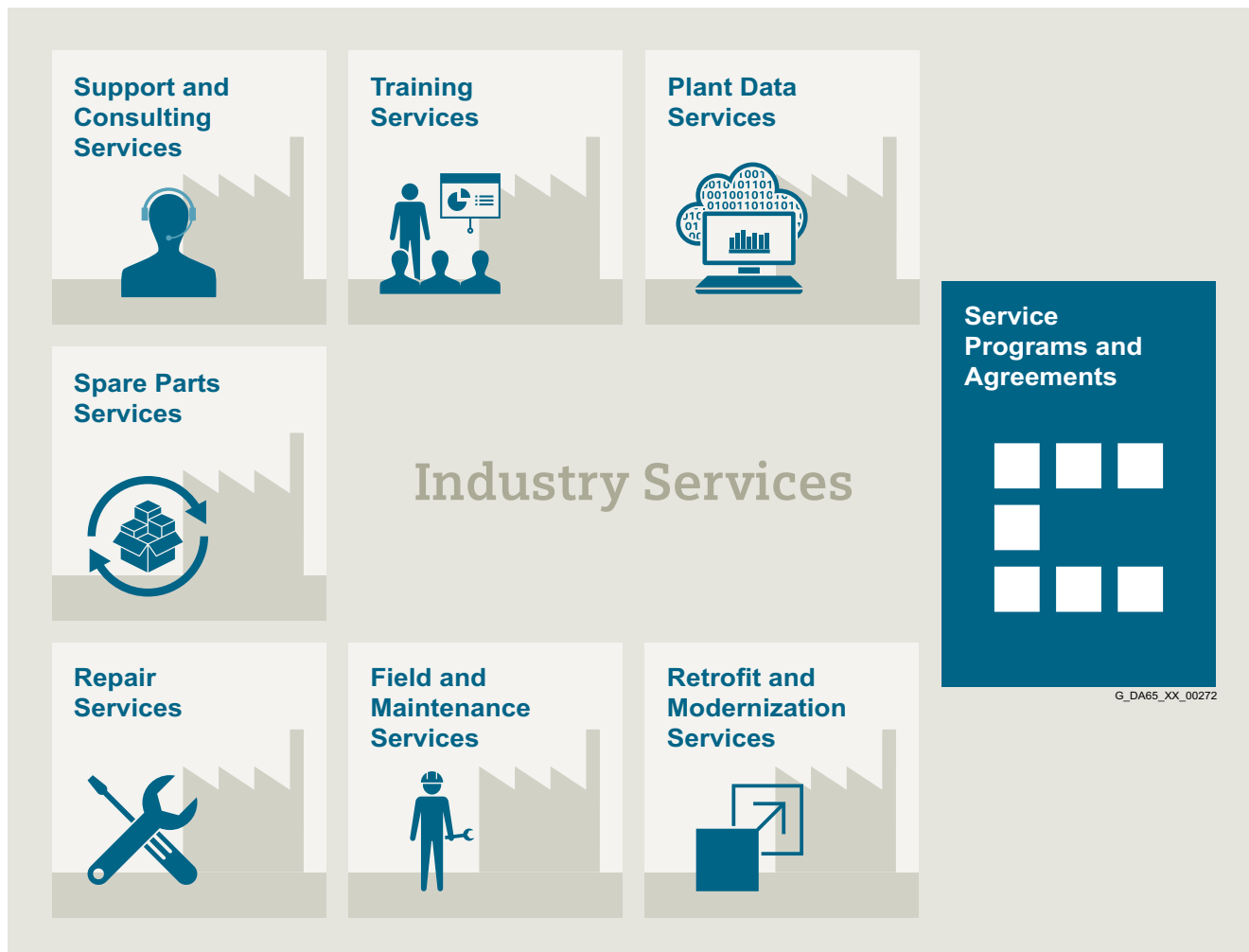

6

Increase your performance – with Industry Services

Optimizing the productivity of your equipment and operations can be a challenge, especially with constantly changing market conditions. Working with our service experts makes it easier. We understand your industry's unique processes and provide the services needed so that you can better achieve your business goals.

You can count on us to maximize your uptime and minimize your downtime, increasing your operations' productivity and reliability. When your operations have to be changed quickly to meet a new demand or business opportunity, our services give you the flexibility to adapt. Of course, we take care that your production is protected against cyber threats. We assist in keeping your operations as energy and resource efficient as possible and reducing your total cost of ownership. As a trendsetter, we ensure that you can capitalize on the opportunities of digitalization and by applying data analytics to enhance decision making: You can be sure that your plant reaches its full potential and retains this over the longer lifespan.

You can rely on our highly dedicated team of engineers, technicians and specialists to deliver the services you need – safely, professionally and in compliance with all regulations. We are there for you, where you need us, when you need us.

Overview

Plant Data Services



Make your industrial processes transparent to gain improvements in productivity, asset availability, and energy efficiency.

Production data is generated, filtered and translated with intelligent analytics to enhance decision-making.

This is done whilst taking data security into consideration and with continuous protection against cyber attack threats.

www.industry.siemens.com/services/global/en/portfolio/plant-data-services/Pages/index.aspx

Support and Consulting Services



Industry Online Support site for comprehensive information, application examples, FAQs and support requests.

Technical and Engineering Support for advice and answers for all inquiries about functionality, handling, and fault clearance.

Information & Consulting Services, e.g. SIMATIC System Audit; clarity about the state and service capability of your automation system or Lifecycle Information Services; transparency on the lifecycle of the products in your plants.

www.industry.siemens.com/services/global/en/portfolio/support-consulting/Pages/index.aspx

Training Services



From the basics and advanced to specialist skills, SITRAIN courses provide expertise right from the manufacturer – and encompass the entire spectrum of Siemens products and systems for the industry.

Worldwide, SITRAIN courses are available wherever you need a training course in more than 170 locations in over 60 countries.

www.industry.siemens.com/services/global/en/portfolio/training/Pages/index.aspx

Spare Parts Services



Are available worldwide for smooth and fast supply of spare parts – and thus optimal plant availability. Genuine spare parts are available for up to ten years. Logistic experts take care of procurement, transport, custom clearance, storage and order management. Reliable logistics processes ensure that components reach their destination as needed.

Asset optimization services help you design a strategy for parts supply where your investment and carrying costs are reduced and the risk of obsolescence is avoided.

www.industry.siemens.com/services/global/en/portfolio/spare_parts/Pages/index.aspx

Appendix

Industry Services

Industry Services – Portfolio overview

Overview (continued)

Repair Services



Are offered on-site and in regional repair centers for fast restoration of faulty devices' functionality.

Also available are extended repair services, which include additional diagnostic and repair measures, as well as emergency services.

www.industry.siemens.com/services/global/en/portfolio/repair_services/Pages/index.aspx

Retrofit and Modernization Services



Provide a cost-effective solution for the expansion of entire plants, optimization of systems or upgrading existing products to the latest technology and software, e.g. migration services for automation systems.

Service experts support projects from planning through commissioning and, if desired over the entire extended lifespan, e.g. Retrofit for Integrated Drive Systems for an extended lifetime of your machines and plants

www.industry.siemens.com/services/global/en/portfolio/retrofit-modernization/Pages/index.aspx

Field and Maintenance Services



Siemens specialists are available globally to provide expert field and maintenance services, including commissioning, functional testing, preventive maintenance and fault clearance. All services can be included in customized service agreements with defined reaction times or fixed maintenance intervals.

www.industry.siemens.com/services/global/en/portfolio/field_service/Pages/index.aspx

Service Programs and Agreements



A technical Service Program or Agreement enables you to easily bundle a wide range of services into a single annual or multi-year agreement.

You pick the services you need to match your unique requirements or fill gaps in your organization's maintenance capabilities.

Programs and agreements can be customized as KPI-based and/or performance-based contracts.

www.industry.siemens.com/services/global/en/portfolio/service_programs/Pages/index.aspx

Overview

Online Support is a comprehensive information system for all questions relating to products, systems, and solutions that Siemens has developed for industry over time. With more than 300,000 documents, examples and tools, it offers users of automation and drive technology a way to quickly find up-to-date information. The 24-hour service enables direct, central access to detailed product information as well as numerous solution examples for programming, configuration and application.

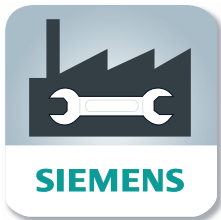
Online Support App

Using the Online Support app, you can access over 300,000 documents covering all Siemens industrial products – anywhere, any time. Regardless of whether you need help implementing your project, fault-finding, expanding your system or are planning a new machine.

You have access to FAQs, manuals, certificates, characteristic curves, application examples, product notices (e.g. announcements of new products) and information on successor products in the event that a product is discontinued.

Just scan the product code printed on the product directly using the camera of your mobile device to immediately see all technical information available on this product at a glance. The graphical CAx information (3D model, circuit diagrams or EPLAN macros) is also displayed. You can forward this information to your workplace using the e-mail function.

The search function retrieves product information and articles and supports you with a personalized suggestion list. You can find your favorite pages – articles you need frequently – under “mySupport”. You also receive selected news on new functions, important articles or events in the News section.

The content, in six languages, is increasingly multimedia-based – and now also available as a mobile app. Online support’s “Technical Forum” offers users the opportunity to share information with each other. The “Support Request” option can be used to contact Siemens’ technical support experts. The latest content, software updates, and news via newsletters and Twitter ensure that industry users are always up to date.

www.siemens.com/industry/onlinesupport

Scan the QR code
for information on
our Online Support
app.



The app is available free of charge from the Apple App Store (iOS) or from Google Play (Android).

<https://support.industry.siemens.com/cs/ww/en/sc/2067>

Appendix

Software Licenses

Overview

Software types

Software requiring a license is categorized into types. The following software types have been defined:

- Engineering software
- Runtime software

Engineering software

This includes all software products for creating (engineering) user software, e.g. for configuring, programming, parameterizing, testing, commissioning or servicing.

Data generated with engineering software and executable programs can be duplicated for your own use or for use by third-parties free-of-charge.

Runtime software

This includes all software products required for plant/machine operation, e.g. operating system, basic system, system expansions, drivers, etc.

The duplication of the runtime software and executable programs created with the runtime software for your own use or for use by third-parties is subject to a charge.

You can find information about license fees according to use in the ordering data (e.g. in the catalog). Examples of categories of use include per CPU, per installation, per channel, per instance, per axis, per control loop, per variable, etc.

Information about extended rights of use for parameterization/configuration tools supplied as integral components of the scope of delivery can be found in the readme file supplied with the relevant product(s).

License types

Siemens Industry Automation & Drive Technologies offers various types of software license:

- Floating license
- Single license
- Rental license
- Rental floating license
- Trial license
- Demo license
- Demo floating license

Floating license

The software may be installed for internal use on any number of devices by the licensee. Only the concurrent user is licensed. The concurrent user is the person using the program. Use begins when the software is started. A license is required for each concurrent user.

Single license

Unlike the floating license, a single license permits only one installation of the software per license.

The type of use licensed is specified in the ordering data and in the Certificate of License (CoL). Types of use include for example per instance, per axis, per channel, etc.

One single license is required for each type of use defined.

Rental license

A rental license supports the "sporadic use" of engineering software. Once the license key has been installed, the software can be used for a specific period of time (the operating hours do not have to be consecutive).

One license is required for each installation of the software.

Rental floating license

The rental floating license corresponds to the rental license, except that a license is not required for each installation of the software. Rather, one license is required per object (for example, user or device).

Trial license

A trial license supports "short-term use" of the software in a non-productive context, e.g. for testing and evaluation purposes. It can be transferred to another license.

Demo license

The demo license support the "sporadic use" of engineering software in a non-productive context, for example, use for testing and evaluation purposes. It can be transferred to another license. After the installation of the license key, the software can be operated for a specific period of time, whereby usage can be interrupted as often as required.

One license is required per installation of the software.

Demo floating license

The demo floating license corresponds to the demo license, except that a license is not required for each installation of the software. Rather, one license is required per object (for example, user or device).

Certificate of license (CoL)

The CoL is the licensee's proof that the use of the software has been licensed by Siemens. A CoL is required for every type of use and must be kept in a safe place.

Downgrading

The licensee is permitted to use the software or an earlier version/release of the software, provided that the licensee owns such a version/release and its use is technically feasible.

Delivery versions

Software is constantly being updated. The following delivery versions

- PowerPack
- Upgrade

can be used to access updates.

Existing bug fixes are supplied with the ServicePack version.

PowerPack

PowerPacks can be used to upgrade to more powerful software. The licensee receives a new license agreement and CoL (Certificate of License) with the PowerPack. This CoL, together with the CoL for the original product, proves that the new software is licensed.

A separate PowerPack must be purchased for each original license of the software to be replaced.

Overview

Upgrade

An upgrade permits the use of a new version of the software on the condition that a license for a previous version of the product is already held.

The licensee receives a new license agreement and CoL with the upgrade. This CoL, together with the CoL for the previous product, proves that the new version is licensed. A separate upgrade must be purchased for each original license of the software to be upgraded.

ServicePack

ServicePacks are used to debug existing products. ServicePacks may be duplicated for use as prescribed according to the number of existing original licenses.

License key

Siemens Industry Automation & Drive Technologies supplies software products with and without license keys.

The license key serves as an electronic license stamp and is also the "switch" for activating the software (floating license, rental license, etc.).

The complete installation of software products requiring license keys includes the program to be licensed (the software) and the license key (which represents the license).

Software Update Service (SUS)

As part of the SUS contract, all software updates for the respective product are made available to you free of charge for a period of one year from the invoice date. The contract will automatically be extended for one year if it is not canceled three months before it expires.

The possession of the current version of the respective software is a basic condition for entering into an SUS contract.

You can download explanations concerning license conditions from www.siemens.com/automation/salesmaterial-as/catalog/en/terms_of_trade_en.pdf

Appendix

Index

A			
Partners at Siemens Industry.....	6/5		
Antennas			
ANT 1	2/131		
ANT 12	2/136		
ANT 18	2/137		
ANT 3	2/132, 2/133		
ANT 30	2/138		
ANT 8	2/134		
ANT D1	2/139		
ANT D10	2/145		
ANT D2	2/140		
ANT D5	2/141		
ANT D6	2/143		
RF620A	3/45		
RF640A	3/48		
RF642A	3/48		
RF660A	3/51		
Antenna multiplexer	2/99, 2/141, 2/143, 2/146		
Antenna switch	2/99, 2/141, 2/143, 2/146		
Asset Management.....	1/4		
C			
CA 01interactive catalog	6/6		
Code readers.....	4/2		
Communication modules			
ASM 456	5/4		
ASM 475	5/22		
RF120C	5/19		
RF160C	5/4		
RF170C	5/16		
RF180C	5/9		
RFID181EIP.....	5/9		
RF182C	5/9		
Configuring instructions for MOBY D.....	2/129		
Container transponder SIMATIC RF620T.....	3/16		
D			
Digital Enterprise	1/7		
Direct part marking.....	4/2		
Disk transponder SIMATIC RF625T	3/20		
H			
Handheld reading systems.....	4/37		
MV320.....	4/39		
MV325.....	4/41		
MV340.....	4/43		
RF210M.....	2/82		
Handheld terminal			
RF350M.....	2/117		
RF650M.....	3/42		
MOBY D.....	2/120		
MV320.....	4/39		
MV325.....	4/41		
MV340.....	4/43		
Heat-resistant transponder			
MDS D124.....	2/26		
MDS D139.....	2/52		
MDS D160.....	2/56		
MDS D339.....	2/54		
RF380T.....	2/73		
RF680L.....	3/11		
RF690L.....	3/12		
RF680T.....	3/26		
I			
Industry Services	6/8		
IO-Link	2/76		
IO-Link master	2/81, 2/85, 2/88, 2/93, 2/97		
L			
Large memory label RF622L.....	3/5		
Large memory transponder RF622T.....	3/18		
Lenses.....	4/32		
Long range reader RF290R.....	2/99		
M			
Mall.....	6/6		
MOBY D	2/120		
O			
Object recognition.....	4/54		
OCR.....	4/50		
On-metal labels			
RF640L.....	3/9		
RF690L.....	3/12		
Optical readers.....	4/37		
MV320	4/39		
MV325	4/41		
MV340	4/43		
P			
Pat-Genius.....	4/54		
Production control.....	1/4		
R			
Readers			
RF210M.....	2/82		
RF210R.....	2/79		
RF220R.....	2/83		
RF240R.....	2/86		
RF250R.....	2/90		
RF260R.....	2/95		
RF290R.....	2/99		
RF310R.....	2/105		
RF340R.....	2/107		
RF350M.....	2/117		
RF350R.....	2/109		
RF380R.....	2/112		
RF382R.....	2/115		
RF650M.....	3/41		
RF650R.....	3/30		
RF680R.....	3/33		
RF685R.....	3/37		
SLG D11/SLG D11S	2/123		
SLG D12/D12S	2/126		
RF200	2/76		
RF300	2/102		
RF600	3/1		
RFID standard cables	5/25		
RFID systems for the HF range	2/1		
RFID systems for the UHF range	3/1		
S			
SCALANCE network components.....	5/27		
W788-1 M12	3/41, 5/30		
X108PoE.....	4/29		
XB205-3.....	4/18, 5/14		
X204IRT PRO.....	5/14		
Scanmode readers			
RF310R.....	2/105		
RF380R.....	2/112		
RF382R.....	2/115		
Screw transponder SIMATIC RF630T.....	3/22		
Siemens Automation Cooperates with Education (SCE).....	6/3		
SIMATIC Ident	1/2		
SITRAIN – Training for Industry	6/2		
Skid identification	2/73		
SmartLabels			
MDS D165	2/8		
MDS D261	2/8		
RF622L	3/5		
RF630L.....	3/6		
RF640L.....	3/9		
RF640T.....	3/24		
RF680L.....	3/11		
RF680T.....	3/26		
RF690L.....	3/12		
RF690T.....	3/9		
RF680L.....	3/11		
RF690L.....	3/12		
RF680T.....	3/26		
RF690T.....	3/12		
T			
Terms and conditions of sale and delivery	6/18		
Text-Genius.....	4/50		
Third-party systems	1/6		
Tool transponder SIMATIC RF640T.....	3/24		
Totally Integrated Automation	1/6		
Tracking & Tracing	1/5		
Transponders			
MDS D100.....	2/10		
MDS D117	2/44		
MDS D124.....	2/26		
MDS D126.....	2/38		
MDS D127.....	2/46		
MDS D139.....	2/52		
MDS D160.....	2/56		
MDS D165.....	2/8		
MDS D200.....	2/12		
MDS D261.....	2/8		
MDS D324.....	2/28		
MDS D339.....	2/54		
MDS D400.....	2/14		
MDS D421.....	2/16		
MDS D422.....	2/20		
MDS D423.....	2/24		
MDS D424.....	2/30		
MDS D425.....	2/34		
MDS D426.....	2/40		
MDS D428.....	2/48		
MDS D460.....	2/58		
MDS D521.....	2/18		
MDS D522.....	2/22		
MDS D524.....	2/32		
MDS D525.....	2/36		
MDS D526.....	2/42		
MDS D528.....	2/50		
RF320T.....	2/61		
RF330T.....	2/63		
RF340T.....	2/65		
RF350T.....	2/67		
RF360T.....	2/69		
RF370T.....	2/71		
RF380T.....	2/73		
RF610T.....	3/14		
RF620T.....	3/16		
RF622L.....	3/5		
RF622T.....	3/18		
RF625T.....	3/20		
RF630L.....	3/6		
RF630T.....	3/22		
RF640L.....	3/9		
RF640T.....	3/24		
RF680L.....	3/11		
RF680T.....	3/26		
RF690L.....	3/12		
V			
Verification systems	4/45		
Veri-Genius	4/45		
W			
Web-based interface for RF600 reader.....	3/29		

3RX9			
3RX9802-0AA00	5/8, 5/15, 5/18		
6ES7			
6ES7137-6BD00-0BA0	2/81, 2/85, 2/88, 2/93, 2/97		
6ES7138-4GA50-0AB0	2/81, 2/85, 2/88, 2/93, 2/97		
6ES7147-5JD00-0BA0	2/81, 2/85, 2/88, 2/93, 2/97		
6ES7148-6JA00-0AB0	2/81, 2/85, 2/88, 2/93, 2/97		
6ES7194-3AA00-0AA0	5/7		
6ES7194-3AA00-0BA0	5/7		
6ES7194-3JA00-0AA0	5/8, 5/14		
6ES7194-4JA50-0AA0	5/14		
6ES7194-4JD50-0AA0	5/14		
6ES7278-4BD32-0XB0	2/81, 2/85, 2/88, 2/93, 2/97		
6ES7390-5AA00-0AA0	5/24		
6ES7390-5BA00-0AA0	5/24		
6ES7392-1AJ00-0AA0	5/24		
6ES7392-1BJ00-0AA0	5/24		
6GF3			
6GF3020-0AC40-0AC0	4/44		
6GF3020-0AC40-0AC1	4/44		
6GF3020-0AC40-0AC3	4/44		
6GF3020-0AC40-0AC4	4/44		
6GF3020-0AC40-0AC5	4/44		
6GF3020-0AC40-0AC7	4/44		
6GF3020-0AC40-0AC8	4/44		
6GF3020-0AC40-0AP1	4/40, 4/44		
6GF3020-0AC40-0AP2	4/40, 4/44		
6GF3320-0AC02	4/40		
6GF3320-0AC03	4/40		
6GF3320-0AC07	4/40		
6GF3320-0HT01	4/40		
6GF3325-0AC03	4/42		
6GF3325-0AC07	4/42		
6GF3325-0HT01	4/42		
6GF3340-0HT01	4/44		
6GF3400-0BH15	4/18, 4/29		
6GF3400-0LT01-7BA1	4/28		
6GF3400-0LT01-8DA1	4/28		
6GF3400-0SL01	4/27, 4/53		
6GF3400-0SL02	4/27, 4/49		
6GF3400-0SL03	4/27, 4/56		
6GF3400-1BH20	4/18, 4/29		
6GF3400-1SL01	4/27, 4/53		
6GF3420-0AA20	4/17		
6GF3420-0AA40	4/17		
6GF3420-0AC00-0LKO	4/17		
6GF3420-0AC00-1AA0	4/18		
6GF3420-0AC00-1LKO	4/17		
6GF3420-0AC00-1LTO	4/17		
6GF3420-0AC00-1PS0	4/18		
6GF3420-0AC00-2AA0	4/17		
6GF3420-0AC00-2CBO	4/18		
6GF3420-0AC00-2LTO	4/17		
6GF3420-0AC00-3LTO	4/17		
6GF3420-0AX20	4/17		
6GF3420-0AX40	4/17		
6GF3440-1CD10	4/27		
6GF3440-1GE10	4/27		
6GF3440-1LE10	4/27		
6GF3440-8AC11	4/27		
6GF3440-8AC12	4/27		
6GF3440-8AC13	4/27		
6GF3440-8AC21	4/27		
6GF3440-8BA2	4/18, 4/29		
6GF3440-8BA4	4/18, 4/29		
6GF3440-8BC4	4/29		
6GF3440-8BD1	4/29		
6GF3440-8CA	4/29		
6GF3440-8CD01	4/29		
6GF3440-8CE	4/49		
6GF3440-8DA11	4/28		
6GF3440-8DA21	4/28		
6GF3440-8DA31	4/28		
6GF3440-8DA41	4/28		
6GF3440-8EA1	4/34		
6GF9			
6GF9001-1AP02	4/33		
6GF9001-1BB01	4/33		
6GF9001-1BE01	4/33		
6GF9001-1BF01	4/33		
6GF9001-1BG01	4/33		
6GF9001-1BH01	4/33		
6GF9001-1BJ01	4/33		
6GF9001-1BK01	4/33		
6GF9001-1BL01	4/33		
6GF9001-1BU	4/34		
6GF9001-1BU01	4/34		
6GF9001-1BV	4/34		
6GF9001-2AD	4/34		
6GF9001-2AE	4/34		
6GF9001-2AF	4/34		
6GF9002-7AD	4/29		
6GK1			
6GK1901-0DB20-6AA0	5/14		
6GK1901-0DM20-2AA5	5/14		
6GK1901-1BB10-2AA0	4/17, 4/28, 5/14		
6GK1901-1BB10-6AA0	5/14		
6GK1905-0CA00	5/7		
6GK1905-0CB00	5/7		
6GK1905-0DA10	5/7		
6GK1905-0EA00	5/8		
6GK1905-0EB00	5/8		
6GK1905-0EC00	5/7		
6GK1905-0FA00	5/8, 5/14		
6GK1905-0FB00	5/8, 5/14		
6GK1907-0AB10-6AA0	5/14		
6GK1907-0DB10-6AA3	5/26		
6GK5			
6GK5108-0PA00-2AA3	4/29		
6GK5204-0JA00-2BA6	5/14		
6GK5205-3BD00-2AB2	4/18, 5/14		
6GK5798-8ML00-0AB3	2/101		
6GT2			
6GT2002-0ED00	5/7		
6GT2002-0EF00	5/7		
6GT2002-0GA10	5/24		
6GT2002-0HD01	5/18		
6GT2002-0JD00	5/13		
6GT2002-0JD10	5/13		
6GT2002-0JD20	5/13		
6GT2002-0LA00	5/20		
6GT2002-1HD01	5/18		
6GT2002-1JD00	5/13		
6GT2002-2JD00	5/13		
6GT2002-4JD00	5/13		
6GT2080-2AA20	2/81, 2/85, 2/88, 2/94, 2/97, 2/101, 2/106, 2/108, 2/110, 2/114, 2/82, 2/82, 2/119, 2/125, 2/127, 3/43, 5/8, 5/15, 5/18, 5/20, 5/24		
6GT2090-0BD00	5/26		
6GT2090-0BE00	5/26		
6GT2090-0QA00	2/74		
6GT2090-0QB00	2/74		
6GT2090-0VB00	5/8, 5/15		
6GT2090-4AN50	5/26		
6GT2090-4AT12	5/26		
6GT2090-4AT80	5/26		
6GT2091-4LH20	5/20, 5/26		
6GT2091-4LH50	5/20, 5/26		
6GT2091-4LN10	5/20, 5/26		
6GT2190-0AA00	2/11, 2/13, 2/15, 2/70, 3/15		
6GT2190-0AB00	2/11, 2/13, 2/15, 2/70, 3/15		
6GT2390-0AA00	2/11, 2/13, 2/15		
6GT2390-1AB00	2/125, 2/127		
6GT2391-0AH30	2/119, 2/132, 2/133, 2/135		
6GT2398-1CA00	2/93, 2/110, 2/119, 2/137		
6GT2398-1CB00	2/110, 2/131		
6GT2398-1CC00	2/93, 2/110, 2/119, 2/136		
6GT2398-1CD00	2/93, 2/110, 2/119, 2/138		
6GT2398-1CD30-0AX0	2/119, 2/132		
6GT2398-1CD40-0AX0	2/93, 2/110, 2/132		
6GT2398-1CD50-0AX0	2/119, 2/133		
6GT2398-1CD60-0AX0	2/93, 2/110, 2/133		
6GT2398-1CF00	2/119, 2/135		
6GT2398-1CF10	2/93, 2/135		
6GT2490-1AA00	2/127		
6GT2491-1HH50	2/125, 2/127		
6GT2491-4EH50	5/24, 5/26		
6GT2491-4EN20	5/24, 5/26		
6GT2491-4EN50	5/24, 5/26		
6GT2590-0QA00	2/74		
6GT2600-0AA10	2/53		
6GT2600-0AB10	2/57		
6GT2600-0AC10	2/27		
6GT2600-0AD10	2/11		
6GT2600-0AE00	2/39		
6GT2600-0AF00	2/47		
6GT2600-0AG00	2/45		
6GT2600-1AA01-0AX0	2/9		
6GT2600-1AB00-0AX0	2/9		
6GT2600-1AD00-0AX0	2/13		
6GT2600-3AA10	2/55		
6GT2600-3AC00	2/29		
6GT2600-4AA00	2/25		
6GT2600-4AB00	2/59		
6GT2600-4AC00	2/31		
6GT2600-4AD00	2/15		
6GT2600-4AE00	2/17		
6GT2600-4AF00	2/21		
6GT2600-4AG00	2/35		
6GT2600-4AH00	2/41		
6GT2600-4AK00-0AX0	2/49		
6GT2600-5AC00	2/33		
6GT2600-5AE00	2/19		
6GT2600-5AF00	2/23		
6GT2600-5AF00-0AX0	2/23		
6GT2600-5AG00	2/37		
6GT2600-5AH00	2/43		
6GT2600-5AK00	2/51		
6GT2601-0AB00	2/127		
6GT2602-0AB00	2/127		
6GT2602-0AB10-0AX0	2/127		
6GT2690-0AA00	2/53, 2/55		
6GT2690-0AC00	2/101, 2/141, 2/143		
6GT2690-0AD00	2/101, 2/143		
6GT2690-0AE00	2/25, 2/64		
6GT2690-0AG00	2/57, 2/59		
6GT2690-0AH00	2/53, 2/55		

Appendix

Article number index

6GT2690-0AH10	2/53, 2/55	6GT2811-6CA10-2AA0	3/40	6XV1	
6GT2690-0AK00	2/27, 2/29, 2/31, 2/33, 2/62, 2/64	6GT2812-0AA00	3/52	6XV1822-5BE30	5/7, 5/13
6GT2690-0AL00	2/39, 2/41, 2/43	6GT2812-0AA01	3/52	6XV1822-5BE50	5/7, 5/13
6GT2691-0CH33	2/141, 2/143, 2/146	6GT2812-0GA08	3/49	6XV1822-5BH10	5/7, 5/13
6GT2691-0CN10	2/141, 2/143, 2/146	6GT2812-1EA00	3/46	6XV1822-5BH15	5/7, 5/13
6GT2691-0DH72	2/139, 2/141, 2/143, 2/146	6GT2812-1EA01	3/46	6XV1822-5BH20	5/7, 5/13
6GT2691-4BH50	2/125, 2/127, 5/26	6GT2812-1GA08	3/49	6XV1822-5BH30	5/7, 5/13
6GT2691-4BN20	2/125, 2/127, 5/26	6GT2813-0CA00	3/43	6XV1822-5BH50	5/7, 5/13
6GT2691-4FH20	5/8, 5/15, 5/18, 5/20, 5/26	6GT2813-0CA10	3/43	6XV1822-5BN10	5/7, 5/13
6GT2698-1AC00	2/125	6GT2815-0BH10	3/46, 3/49, 3/52	6XV1822-5BN15	5/7, 5/13
6GT2698-2AC00	2/125	6GT2815-0BH30	3/46, 3/49, 3/52	6XV1830-0EH10	5/8
6GT2698-5AA10	2/101, 2/125, 2/141	6GT2815-0BN10	3/46, 3/49, 3/52	6XV1830-3DE30	5/7
6GT2698-5AB00	2/101, 2/143	6GT2815-0BN20	3/46, 3/49, 3/52	6XV1830-3DE50	5/7
6GT2698-5AC00	2/139	6GT2815-0BN40	3/46, 3/49, 3/52	6XV1830-3DH10	5/7
6GT2698-5AF00	2/101, 2/146	6GT2815-1BN10	3/46, 3/49, 3/52	6XV1830-3DH15	5/7
6GT2698-5BB00	2/125, 2/140	6GT2815-2BH50	3/46, 3/49, 3/52	6XV1830-3DH20	5/7
6GT2800-1CA00	2/62	6GT2815-2BN15	3/46, 3/49, 3/52	6XV1830-3DH30	5/7
6GT2800-4AC00	2/70	6GT2821-0AC12	2/101	6XV1830-3DH50	5/7
6GT2800-4BB00	2/66	6GT2821-1AC10	2/81	6XV1830-3DN10	5/7
6GT2800-5AC00	2/70	6GT2821-1AC32	2/81	6XV1830-3DN15	5/7
6GT2800-5BA00	2/64	6GT2821-2AC10	2/85	6XV1830-7AH10	5/7
6GT2800-5BB00	2/66	6GT2821-2AC32	2/85	6XV1830-7BH05	5/7
6GT2800-5BD00	2/67	6GT2821-4AC10	2/88	6XV1830-7BH10	5/7
6GT2800-5BE00	2/72	6GT2821-4AC32	2/88	6XV1830-7BH15	5/7
6GT2800-5DA00	2/74	6GT2821-4AC40	2/88	6XV1830-7BH30	5/7
6GT2800-6BE00	2/72	6GT2821-5AC10	2/93	6XV1830-7BH50	5/7
6GT2801-1AB10	2/106	6GT2821-5AC32	2/93	6XV1830-7BN10	5/7
6GT2801-1AB20-0AX1	2/106	6GT2821-5AC40	2/93	6XV1830-7BN15	5/7
6GT2801-2AB10	2/108	6GT2821-6AC10	2/97	6XV1830-7BN20	5/7
6GT2801-3AB10	2/114	6GT2821-6AC32	2/97	6XV1830-7BN25	5/7
6GT2801-3AB20-0AX0	2/82	6GT2821-6AC40	2/97	6XV1830-7BN30	5/7
6GT2801-3AB20-0AX1	2/114	6GT2823-0AA00	2/82	6XV1830-7BN35	5/7
6GT2801-4AB10	2/110	6GT2890-0AA00	3/49, 3/52	6XV1830-7BN40	5/7
6GT2803-0BM00	2/119	6GT2890-0AB00	3/32, 3/36, 3/40	6XV1830-7BN45	5/7
6GT2803-0CA00	2/119	6GT2891-0CH50	3/32, 3/36, 3/40	6XV1830-7BN50	5/7
6GT2803-1BA00	2/119	6GT2891-0PH50	3/32, 3/36, 3/40	6XV1830-8AH10	5/8, 5/15
6GT2803-1BA10	2/119	6GT2891-4EH20	5/24, 5/26	6XV1840-2AH10	5/14
6GT2810-2AB00	3/8	6GT2891-4EH50	3/32, 3/36, 3/40, 5/24, 5/26	6XV1870-3QN10	3/32
6GT2810-2AB01	3/8	6GT2891-4FH20	4/18, 4/29, 5/8, 5/15, 5/18, 5/20, 5/24, 5/26	6XV1870-8AE30	4/17, 4/28, 5/13
6GT2810-2AB02-0AX0	3/8	6GT2891-4FH50	4/18, 4/29, 5/8, 5/15, 5/18, 5/20, 5/24, 5/26	6XV1870-8AE50	4/17, 4/28, 5/13
6GT2810-2AB03	3/8	6GT2891-4FN10	4/18, 4/29, 5/8, 5/15, 5/18, 5/20, 5/24, 5/26	6XV1870-8AH10	4/17, 4/28, 5/13
6GT2810-2AC00	3/10	6GT2891-4FN20	4/18, 4/29, 5/8, 5/15, 5/18, 5/20, 5/24, 5/26	6XV1870-8AH15	4/17, 4/28, 5/13
6GT2810-2AC10	3/10	6GT2891-4FN50	4/18, 4/29, 5/8, 5/15, 5/18, 5/20, 5/24, 5/26	6XV1870-8AH20	4/17, 4/28, 5/13
6GT2810-2AC80	3/5	6GT2891-4JH20	5/8, 5/15, 5/18, 5/20, 5/26	6XV1870-8AH30	4/17, 4/28, 5/13
6GT2810-2AE81-0AX1	3/8	6GT2891-4JH50	5/8, 5/15, 5/18, 5/20, 5/26	6XV1870-8AH50	3/36, 3/40, 4/17, 4/28, 5/13
6GT2810-2AG00	3/13	6GT2891-4JN10	5/8, 5/15, 5/18, 5/20, 5/26	6XV1870-8AN10	4/17, 4/28, 5/13
6GT2810-2AG10	3/13	6GT2891-4KH20	2/88, 2/94, 2/97, 2/101, 2/114, 2/82, 5/26	6XV1870-8AN15	4/17, 4/28, 5/13
6GT2810-2AG80	3/11	6GT2891-4KH50	2/88, 2/94, 2/97, 2/101, 2/114, 2/82, 5/26	6XV1871-5Bxxx	3/32
6GT2810-2BB80	3/15	6GT2891-4LH50	2/81, 2/85, 2/88, 2/94, 2/97	6XV1871-5TH20	4/17, 4/28, 5/14
6GT2810-2BB80-0AX0	3/15	6GT2891-4LN10	2/81, 2/85, 2/88, 2/94, 2/97	6XV1871-5TH30	4/17, 4/28, 5/14
6GT2810-2DC00	3/25	6GT2891-4MH50	2/81, 2/85, 2/88, 2/94, 2/97	6XV1871-5TH50	3/36, 3/40, 4/17, 4/28, 5/14
6GT2810-2DC10	3/25	6GT2891-4MN10	2/81, 2/85, 2/88, 2/94, 2/97	6XV1871-5TN10	4/17, 4/28, 5/14
6GT2810-2EC00	3/23	6GT2894-0EA00	2/101, 2/141, 2/143, 2/146	6XV1871-5TN15	4/17, 4/28, 5/14
6GT2810-2EC10	3/23	6GT2898-0AA00	2/125, 2/127, 3/32, 3/36, 3/40		
6GT2810-2EE00	3/21	6GT2898-0AA10	2/125, 2/127, 3/32, 3/36, 3/40		
6GT2810-2EE01	3/21	6GT2898-0AA20	2/125, 2/127, 3/32, 3/36, 3/40		
6GT2810-2HC81	3/17	6GT2898-0BB00	3/43		
6GT2810-2HG80	3/27	6GT2898-0CB00	3/43		
6GT2810-4HC80	3/19	6GT2898-0EA00	2/119, 2/132, 2/134, 2/136		
6GT2811-6AA10-0AA0	3/36	6GT2898-2AA00	3/17		
6GT2811-6AA10-1AA0	3/36	6GT2898-3AA00	3/19		
6GT2811-6AA10-2AA0	3/36	6GT2898-4AA10	3/32, 3/36, 3/40		
6GT2811-6AB20-0AA0	3/32				
6GT2811-6AB20-1AA0	3/32				
6GT2811-6AB20-2AA0	3/32				
6GT2811-6CA10-0AA0	3/40				
6GT2811-6CA10-1AA0	3/40				

Appendix

Conditions of sale and delivery

1. General Provisions

By using this catalog you can acquire hardware and software products described therein from Siemens AG subject to the following Terms and Conditions of Sale and Delivery (hereinafter referred to as "T&C"). Please note that the scope, the quality and the conditions for supplies and services, including software products, by any Siemens entity having a registered office outside Germany, shall be subject exclusively to the General Terms and Conditions of the respective Siemens entity. The following T&C apply exclusively for orders placed with Siemens Aktiengesellschaft, Germany.

1.1 For customers with a seat or registered office in Germany

For customers with a seat or registered office in Germany, the following applies subordinate to the T&C:

- the "General Terms of Payment"¹⁾ and,
- for software products, the "General License Conditions for Software Products for Automation and Drives for Customers with a Seat or Registered Office in Germany"¹⁾ and,
- for other supplies and services, the "General Conditions for the Supply of Products and Services of the Electrical and Electronics Industry"¹⁾.

1.2 For customers with a seat or registered office outside Germany

For customers with a seat or registered office outside Germany, the following applies subordinate to the T&C:

- the "General Terms of Payment"¹⁾ and,
- for software products, the "General License Conditions for Software Products for Automation and Drives for Customers with a Seat or Registered Office outside of Germany"¹⁾ and

for other supplies and/or services, the "General Conditions for Supplies of Siemens Industry for Customers with a Seat or Registered Office outside of Germany"¹⁾.

2. Prices

The prices are in € (Euro) ex point of delivery, exclusive of packaging.

The sales tax (value added tax) is not included in the prices. It shall be charged separately at the respective rate according to the applicable statutory legal regulations.

Prices are subject to change without prior notice. We will charge the prices valid at the time of delivery.

To compensate for variations in the price of raw materials (e.g. silver, copper, aluminum, lead, gold, dysprosium and neodym), surcharges are calculated on a daily basis using the so-called metal factor for products containing these raw materials. A surcharge for the respective raw material is calculated as a supplement to the price of a product if the basic official price of the raw material in question is exceeded.

The metal factor of a product indicates the basic official price (for those raw materials concerned) as of which the surcharges on the price of the product are applied, and with what method of calculation.

You will find a detailed explanation of the metal factor on the page headed "Metal surcharges".

To calculate the surcharge (except in the cases of dysprosium and neodym), the official price from the day prior to that on which the order was received or the release order was effected is used.

To calculate the surcharge applicable to dysprosium and neodym ("rare earths"), the corresponding three-month basic average price in the quarter prior to that in which the order was received or the release order was effected is used with a one-month buffer (details on the calculation can be found in the explanation of the metal factor).

3. Additional Terms and Conditions

The dimensions are in mm. In Germany, according to the German law on units in measuring technology, data in inches apply only to devices for export.

Illustrations are not binding.

Insofar as there are no remarks on the individual pages of this catalog - especially with regard to data, dimensions and weights given - these are subject to change without prior notice.

4. Export regulations

We shall not be obligated to fulfill any agreement if such fulfillment is prevented by any impediments arising out of national or international foreign trade or customs requirements or any embargoes and/or other sanctions.

Export of goods listed in this catalog may be subject to licensing requirements. We will indicate in the delivery details whether licenses are required under German, European and US export lists. Goods labeled with "AL" not equal to "N" are subject to European or German export authorization when being exported out of the EU. Goods labeled with "ECCN" not equal to "N" are subject to US re-export authorization.

The export indications can be viewed in advance in the description of the respective goods on the Industry Mall, our online catalog system. Only the export labels "AL" and "ECCN" indicated on order confirmations, delivery notes and invoices are authoritative.

Even without a label, or with label "AL:N" or "ECCN:N", authorization may be required i.a. due to the final disposition and intended use of goods.

If you transfer goods (hardware and/or software and/or technology as well as corresponding documentation, regardless of the mode of provision) delivered by us or works and services (including all kinds of technical support) performed by us to a third party worldwide, you must comply with all applicable national and international (re-)export control regulations.

If required for the purpose of conducting export control checks, you (upon request by us) shall promptly provide us with all information pertaining to the particular end customer, final disposition and intended use of goods delivered by us respectively works and services provided by us, as well as to any export control restrictions existing in this relation.

The products listed in this catalog may be subject to European/German and/or US export regulations. Any export requiring approval is therefore subject to authorization by the relevant authorities.

Errors excepted and subject to change without prior notice.

¹⁾ The text of the Terms and Conditions of Siemens AG can be downloaded at www.siemens.com/automation/salesmaterial-as/catalog/en/terms_of_trade_en.pdf

Further information can be obtained from our branch offices listed at www.siemens.com/automation/partner

Interactive Catalog on DVD Products for Automation and Drives	<i>Catalog</i> CA 01		
Building Control GAMMA Building Control		ET G1	
Drive Systems SINAMICS G130 Drive Converter Chassis Units SINAMICS G150 Drive Converter Cabinet Units SINAMICS GM150, SINAMICS SM150 Medium-Voltage Converters SINAMICS PERFECT HARMONY GH180 Medium-Voltage Air-Cooled Drives Germany Edition SINAMICS G180 Converters – Compact Units, Cabinet Systems, Cabinet Units Air-Cooled and Liquid-Cooled SINAMICS S120 Chassis Format Units and Cabinet Modules SINAMICS S150 Converter Cabinet Units SINAMICS DCM DC Converter, Control Module SINAMICS DCM Cabinet SINAMICS Inverters for Single-Axis Drives and SIMOTICS Motors SINAMICS G120P and SINAMICS G120P Cabinet pump, fan, compressor converters LOHER VARIO High Voltage Motors Flameproof, Type Series 1PS4, 1PS5, 1MV4 and 1MV5 Frame Size 355 to 1000, Power Range 80 to 7100 kW Three-Phase Induction Motors SIMOTICS HV, SIMOTICS TN • Series H-compact • Series H-compact PLUS High Voltage Three-phase Induction Motors SIMOTICS HV Series A-compact PLUS Three-Phase Induction Motors SIMOTICS HV, Series H-compact Synchronous Motors with Permanent-Magnet Technology, HT-direct DC Motors SIMOREG DC MASTER 6RA70 Digital Chassis Converters SIMOREG K 6RA22 Analog Chassis Converters <i>Digital: SIMOREG DC MASTER 6RM70 Digital Converter Cabinet Units</i> SIMOVERT PM Modular Converter Systems SIEMOSYN Motors MICROMASTER 420/430/440 Inverters MICROMASTER 411/COMBIMASTER 411 <u>Low-Voltage Three-Phase-Motors</u> SIMOTICS Low-Voltage Motors SIMOTICS FD Low-Voltage Motors LOHER Low-Voltage Motors MOTOX Geared Motors SIMOGEAR Geared Motors SIMOGEAR Gearboxes with adapter <u>Mechanical Driving Machines</u> FLENDER Standard Couplings FLENDER High Performance Couplings FLENDER Backlash-free Couplings FLENDER SIP Standard industrial planetary gear units	D 11 D 12 D 15.1 D 18.1 D 21.3 D 23.1 D 23.2 D 31 D 35 D 83.2 D 84.1 D 84.9 D 86.1 D 86.2 DA 12 DA 21.1 DA 21.2 <i>DA 22</i> DA 45 DA 48 DA 51.2 DA 51.3 D 81.1 D 81.8 D 83.1 D 87.1 MD 50.1 MD 50.11 MD 10.1 MD 10.2 MD 10.3 MD 31.1		
Process Instrumentation and Analytics <i>Digital: Field Instruments for Process Automation</i> <i>Digital: SIPART Controllers and Software</i> Products for Weighing Technology <i>Digital: Process Analytical Instruments</i> <i>Digital: Process Analytics, Components for Continuous Emission Monitoring</i>	<i>FI 01</i> <i>MP 31</i> WT 10 <i>AP 01</i> <i>AP 11</i>		
Low-Voltage Power Distribution and Electrical Installation Technology	<i>Catalog</i>		
SENTRON · SIVACON · ALPHA Protection, Switching, Measuring and Monitoring Devices, Switchboards and Distribution Systems Standards-Compliant Components for Photovoltaic Plants Electrical Components for the Railway Industry TÜV-certified Power Monitoring System Components for Industrial Control Panels according to UL Standards 3WT Air Circuit Breakers up to 4000 A 3VT Molded Case Circuit Breakers up to 1600 A <i>Digital: SIVACON System Cubicles, System Lighting and System Air-Conditioning</i> <i>Digital: ALPHA Distribution Systems</i> ALPHA FIX Terminal Blocks SIVACON S4 Power Distribution Boards SIVACON 8PS Busbar Trunking Systems <i>Digital: DELTA Switches and Socket Outlets</i>		LV 10 LV 11 LV 12 LV 14 LV 16 LV 35 LV 36 LV 50 LV 51 LV 52 LV 56 LV 70 ET D1	
Motion Control SINUMERIK 840 Equipment for Machine Tools SINUMERIK 808 Equipment for Machine Tools SINUMERIK 828 Equipment for Machine Tools SIMOTION, SINAMICS S120 & SIMOTICS Equipment for Production Machines <i>Digital: Drive and Control Components for Cranes</i>		NC 62 NC 81.1 NC 82 PM 21 CR 1	
Power Supply SITOP Power supply		KT 10.1	
Safety Integrated Safety Technology for Factory Automation		SI 10	
SIMATIC HMI / PC-based Automation Human Machine Interface Systems/ PC-based Automation		ST 80/ ST PC	
SIMATIC Ident Industrial Identification Systems		ID 10	
SIMATIC Industrial Automation Systems Products for Totally Integrated Automation SIMATIC PCS 7 Process Control System System components SIMATIC PCS 7 Process Control System Technology components Add-ons for the SIMATIC PCS 7 Process Control System		ST 70 ST PCS 7 ST PCS 7 T ST PCS 7 AO	
SIMATIC NET Industrial Communication		IK PI	
SIRIUS Industrial Controls <i>Digital: SIRIUS Industrial Controls</i>		IC 10	

*Digital: These catalogs are only available as a PDF.***Information and Download Center**

Digital versions of the catalogs are available on the Internet at:
www.siemens.com/industry/infocenter
 There you'll find additional catalogs in other languages.
 Please note the section "Downloading catalogs" on page
 "Online services" in the appendix of this catalog.

Security information:

Siemens provides products and solutions with industrial security functions that support the secure operation of plants, solutions, machines, equipment and/or networks. They are important components in a holistic industrial security concept. With this in mind, Siemens' products and solutions undergo continuous development. Siemens recommends strongly that you regularly check for product updates.

For the secure operation of Siemens products and solutions, it is necessary to take suitable preventive action (e.g. cell protection concept) and integrate each component into a holistic, state-of-the-art industrial security concept. Third-party products that may be in use should also be considered. For more information about industrial security, visit <http://www.siemens.com/industrialsecurity>.

To stay informed about product updates as they occur, sign up for a product-specific newsletter. For more information, visit <http://support.industry.siemens.com>

Siemens Industry, Inc.
5300 Triangle Parkway
Norcross, GA 30092
U.S.A.

Subject to change without prior notice
Article No. E86060-K8310-A101-B1-7600
W-FPN6Z-PD-PAK06 / Dispo 26107
KG 0216 1.0 DPG 322 En
Printed in Germany
© Siemens AG 2016

The information provided in this brochure contains merely general descriptions or characteristics of performance which in case of actual use do not always apply as described or which may change as a result of further development of the products. An obligation to provide the respective characteristics shall only exist if expressly agreed in the terms of contract. Availability and technical specifications are subject to change without notice. All product designations may be trademarks or product names of Siemens AG or supplier companies whose use by third parties for their own purposes could violate the rights of the owners.